



WWW.ACTIVEFOAM.COM

2019

CHICAGO, ILLINOIS

MILWAUKEE, WISCONSIN

EASTPOINTE, MICHIGAN

NORTH LIMA, OHIO

TABLE OF CONTENTS

INTRODUCTION / MAPS / PHOTOS	1-7
SECTION 1	FOAM 8-60
SECTION 2	CUSHION WRAPS: <i>BONDED</i> and <i>SEWN DACRONS</i> 61-65
SECTION 3	POLYESTER PILLOW FILLS 66
SECTION 4	POLYESTER PADDINGS / DENSIFIED FIBERS 67-68
SECTION 5	COTTON PADDINGS 69
SECTION 6	THREADS 70-74
SECTION 7	TWINES 75
SECTION 8	ZIPPERS (<i>Furniture</i>) 76
SECTION 9	WEBBING 77-79
SECTION 10	WELTCORD 80-81
SECTION 11	BURLAPS / BARRIER FABRICS 82
SECTION 12	ACCORD / LININGS / DENIMS / MUSLIN / TICKINGS / FLAME BARRIERS 83-86
SECTION 13	ROLL-EDGE / EDGINGS 87
SECTION 14	PILLOWS: <i>KAPOK</i> and <i>DOWN</i> 88-89
SECTION 15	SPRINGS 90-95
SECTION 16	CASTERS 96-99
SECTION 17	ADHESIVES 100-107
SECTION 18	CLEANERS / SILICONES 108-109
SECTION 19	STAPLES / GUNS / TACKS / NAILS / PLI-GRIP 110-117
SECTION 20	DECORATIVE NAILS 118-122
SECTION 21	BUTTONS 123-127
SECTION 22	LEGS / GLIDES 128-133
SECTION 23	REFINISHING 134-135
SECTION 24	TOOLS / SEWING MACHINE NEEDLES 136-149
SECTION 25	GIMPS / CANES 150-151
SECTION 26	CANVAS / DUCKS / NYLONS / MISC. FABRICS 152-157
SECTION 27	SUNBRELLA: <i>MARINE</i> and <i>OUTDOOR FABRICS</i> 157-163
SECTION 28	VINYLS 164-205
SECTION 29	URETHANES 206-209
SECTION 30	LEATHERS 210-211
SECTION 31	FABRICS: <i>VELVETS</i> / <i>TAPESTRIES</i> / <i>CONTRACT</i> 212-215
SECTION 32	ZIPPERS (<i>Marine</i>) / <i>VELCROS</i> 216-218
SECTION 33	AUTO AND MARINE SUPPLIES 219-235
SECTION 34	CONVERTIBLE TOPS: WINDOWS AND ORIGINALS 236-239
SECTION 35	AUTO AND MARINE SUPPLIES 240-244
SECTION 36	INDEX 245-252
SECTION 37	TERMS AND CONDITIONS 253
SECTION 38	CREDIT APPLICATION / TAX FORM (<i>tear-off form</i>) 254-255



MISSION *We are committed to bringing our customers the most valued line of products and services in the industry. Going beyond the basics is what separates Active Foam from our competitors. Our goal is to fully support your efforts in your custom trade enabling greater success and enjoyment, by increasing your profitability.*

ABOUT US **Active Foam is an American owned and operated company for over half a century!**

Active Foam Products was established in Chicago, Illinois in 1958. Originally, our emphasis centered on fabricated foam for the custom upholstery market; with the acquisition of Illinois Upholstery Supply Company in 1963, the primary focus was expanded to include distribution of upholstery supplies. In 1982, Active Foam came into its current ownership. With the goal of better meeting the needs of a growing customer base, we began the process of developing our company into one of the premiere suppliers for the custom upholstery trade.

By 1992, active Foam Products expanded into Milwaukee, Wisconsin, by establishing not only a fully stocked upholstery supply warehouse, but an additional foam fabricating facility. This geographic expansion also brought with it an addition of many new product lines; most notably, Spradling Vinyls. This expansion proved so successful, that within three (3) short years, we moved into a 21,000 square foot facility adding new machines and capabilities to meet with growing demands.

The 90's were fairly busy for our main plant in Chicago as well, so by 1998, we were ready for another expansion. Our 43,000 square foot warehouse met this need admirably. More space for additional equipment enabled more efficiency and cost effectiveness; plus the ability to add new services previously unseen before in this industry.

The purchase of Foam Distributing in 2003, a foam fabricator with over 20 years of established roots in Detroit, Michigan, brought our locations up to three (3) facilities. This location also became an upholstery supply line bringing to market a full line supply house to serve eastern Michigan. Then in 2006, per market demand, we expanded into Eastpointe suburb with a 21,000 foot facility.

In our ongoing efforts to provide state of the art customizing for our clients, we added computerized cutting equipment to our Chicago and Milwaukee locations in 2007. Now, with the equipment and capabilities typically found only with large manufacturers, but with the more "attention to detail" personal touch and atmosphere; no job is too small.

The next year brought more options for our customers when we added Enduratex Vinyls to our inventory in both Chicago and Eastpointe. This enabled us to support your residential, marine, automotive and contract needs, and by early 2009, we had acquired Century Fabrics adding their fabric lines to our Chicago plant. These Boltflex, Nassimi, Morbern, and Naugahyde vinyls have made it possible for us to offer a large variety of options for our customers.

In September of 2009, we purchased Fabric Service of Chicago; an automotive and trim supply house. This acquisition added the distribution capabilities of OEM and aftermarket products for auto trimmers' interior and exterior requirements.

By 2010, we had acquired yet another upholstery supply company, Simko, just outside of Youngstown, Ohio, in the town of Poland. Founded by Tom Simko in 1991, Simko Upholstery Supply serviced northeastern Ohio and western Pennsylvania upholsterers.

Today, we have a 240+ page catalog listing products and services second to none. Our current service area covers most of the Midwest, and our market is expanding daily.

Whatever your custom upholstery or fabrication needs may be, no matter how small a job, our skilled staff can make it happen. If you do not find a particular part in our catalog you need, give us a call; if it exists, we will find it for you!



SPECIAL SERVICES

<u>SPECIAL SERVICES</u>	<u>PAGE</u>
CUSTOM MADE MATTRESSES	42
CUSTOM SHAPED FOAMS	14, 45-49, 52-59
CUSTOM BONDED FIBERFILL <i>and</i> DACRON WRAPS	68
CUSTOM CUTTING of FIBERFILLS <i>and</i> PADDINGS to size and patterns	68
CUSTOM MADE PILLOW INSERTS	89
SPECIAL BUTTON MAKING SERVICE	123
CUSTOM EMBOSSING & PERFORATING for VINYL <i>and</i> LEATHER	211, 239

FOAM HIGHLIGHTS

50+ Foam types
 Conventional urethanes
 HR urethanes
 Flotation foam
 Neoprenes
 Visco elastic foams
 Urethane sponge
 Ester foam
 Reticulated foams
 Bonded foams
 Cross-link polyethylene
 Polyethylene plank
 Polyethylene rolls
 Buffing foams
 Marine foams
 Slow recovery foams
 Urethane cloth-backed
 Neoprene cloth-backed
 FAA foams
 Fast dry foams
 Anti-microbial foams
 Sound deadening

FABRICATING HIGHLIGHTS

Cut-to-size patterns
 Multi-piece assemblies
 Profile pattern cutting
 Wedged pattern cutting
 Buffed and beveled edging
 Cloth backings
 Round bolsters
 Custom mattress cores
 Specialized seating

MARKET HIGHLIGHTS

Upholstered furniture
 Restaurant booths
 Marine seating
 Theater seating
 Church pews
 Health-care devices
 Novelty products
 Consumer products
 Automotive interiors
 Case inserts
 Industrial applications
 Motorcycle seating

SUPPLY HIGHLIGHTS

Sewn dacron cushion wraps
 Bonded fiberfill cushion wraps
 Low melt bonded cushion wraps
 Threads
 Webbing
 Weltcords
 Woven and non-woven tickings
 Pillows: polyester and down filled
 Natural and synthetic downs
 Springs and accessories
 Casters
 Adhesives: over 20 types
 Staples and fasteners
 Decorative nails
 Buttons
 Tools and needles
 Canvas: cotton and synthetics
 Contract vinyls
 Contract fabrics
 Industrial fabrics and vinyls
 Leather

CHICAGO KEY CONTACTS

PRESIDENT
OFFICE MANAGER
INSIDE SALES SPECIALIST
PURCHASING MANAGER
PLANT MANAGER
CUSTOMER SERVICE MANAGER
ACCOUNTS PAYABLE
SALES

SCOTT MEYER
ARNIE SINACORE
DENNIS STANCZAK
BOB JANUSZ
ROBERT ROMERO
CAROLE EATON
CHRISTINA PTAK
PETE LETTIERE

SCOTT.M@ACTIVEFOAM.COM
ARNIE@ACTIVEFOAM.COM
DENNIS@ACTIVEFOAM.COM
BOB@ACTIVEFOAM.COM
ROBERT.ROMERO@ACTIVEFOAM.COM
CAROLE@ACTIVEFOAM.COM
CHRISTINA@ACTIVEFOAM.COM
PETE@ACTIVEFOAM.COM

ACTIVE FOAM PRODUCTS, INC.
4358 SOUTH KNOX AVENUE
CHICAGO, IL 06032
TOLL FREE: 800-728-4567
PHONE: 773-582-5400
FAX: 773-582-1955
E-MAIL: CHICAGO@ACTIVEFOAM.COM
WEB SITE: WWW.ACTIVEFOAM.COM



SCOTT MEYER
President



ARNIE SINACORE
Office Manager



PETE LETTIERE
Account Manager



DENNIS STANCZAK
Account Manager



CAROLE EATON
Customer Service Manager



DONNA KOOP
Customer Service



CHRISTINA PTAK
Accounts Payable



DESTINY BARNES
Customer Service



BOB JANUSZ
Purchasing Manager



ROBERT ROMERO
Plant Manager

Directions from Cicero and "The Stevenson" - Route 55

- Travel south to 43rd Street; 43rd Street is the first street south of the expressway.
 - Make a left on 43rd at the light and go to the end of the street which is 3 blocks.
 - Turn right and travel one block. The office entrance is on the corner of 44th and South Knox.
- Cicero Ave. is 6 miles west of the Kennedy and Dan Ryan Expressway; from 294 the "Tri-State" is 8 miles.

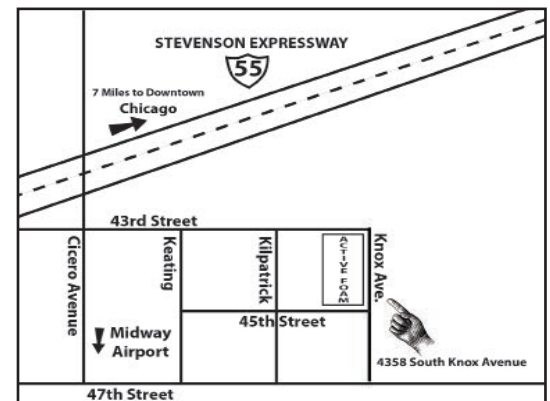

MILWAUKEE KEY CONTACTS

GENERAL MANAGER
OFFICE MANAGER
CUSTOMER SERVICE
SALES
SALES
FABRICATION
GENERAL MAILBOX

JOE PESCHMAN
DIANE MARTIN
RYAN PESCHMAN
JAKE PARRY
CHUCK PASCH
MARK GRANT

JOE@ACTIVEFOAM.COM
DIANE@ACTIVEFOAM.COM
RYAN@ACTIVEFOAM.COM
JACOB.PARRY@ACTIVEFOAM.COM
CHUCK@ACTIVEFOAM.COM
MARK@ACTIVEFOAM.COM
MILWAUKEE@ACTIVEFOAM.COM

ACTIVE FOAM PRODUCTS, INC.
6210 W. DOUGLAS AVE
MILWAUKEE, WI 53218
TOLL FREE: 800-347-3603
PHONE: 414-462-9220
FAX: 414-462-9222
WEB SITE: WWW.ACTIVEFOAM.COM



JOE PESCHMAN
General Manager



DIANE MARTIN
Office Manager



JACOB PARRY
Account Manager



RYAN PESCHMAN
Customer Service



TOM ZEUGNER
Warehouse Service



DAN SELLHAUSEN
Warehouse Service



MARK GRANT
Fabricating Manager



CHUCK PASCH
Account Manager

Directions from US-45

- Travel east on Silverspring Drive approximately 5 miles then make a left onto 64th Street.
- Turn right onto Douglas Avenue and we are the third building on your left.

Directions from I-43

- Travel west on Silverspring Drive approximately 4 miles then make a right on 60th Street.
- Turn left onto Douglas Avenue and we are the third building on your right.

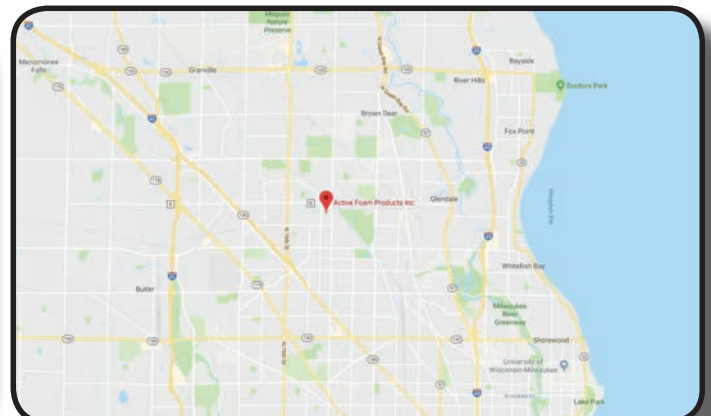

EASTPOINTE KEY CONTACTS

OFFICE MANAGER
CUSTOMER SERVICE
PLANT MANAGER
ACCOUNT MANAGER
GENERAL MAILBOX

LYNN FULTON
TRISHA COLZIN
CHRIS KARCZEWSKI
MARC KEAST

LYNN@ACTIVEFOAM.COM
TRISHA@ACTIVEFOAM.COM
CHRIS@ACTIVEFOAM.COM
MARC@ACTIVEFOAM.COM
EASTPOINTE@ACTIVEFOAM.COM

ACTIVE FOAM PRODUCTS, INC.
17630 EAST 10 MILE RD
EASTPOINTE, MI 48021
TOLL FREE: 866-316-4567
PHONE: 586-778-5400
FAX: 586-778-5415
WEB SITE: WWW.ACTIVEFOAM.COM



LYNN FULTON
Office Manager



CHRIS KARCZEWSKI
Operations Manager



MARC KEAST
Account Manager



TRISHA COLZIN
Customer Service

FROM I-94:

- Take the 10 Mile Rd exit (Exit 228).
- Travel west on 10 Mile Road. We are 1.2 Miles from I-94. (.6 Miles West of Kelly) on the South side of the street.

FROM I-696:

- Take the Gratiot Avenue exit (Exit 27).
- Take Gratiot Avenue South 1 mile to 10 Mile Road.
- Go east on 10 Mile Road for ½ mile. We are on the south side of the street.

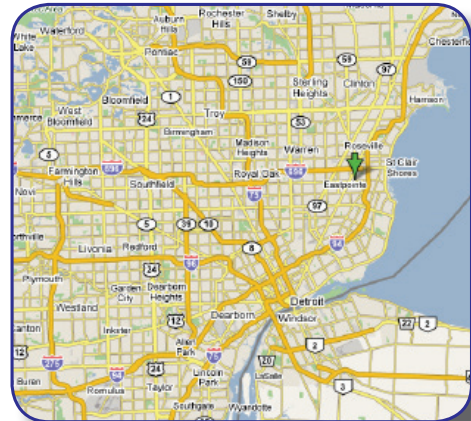
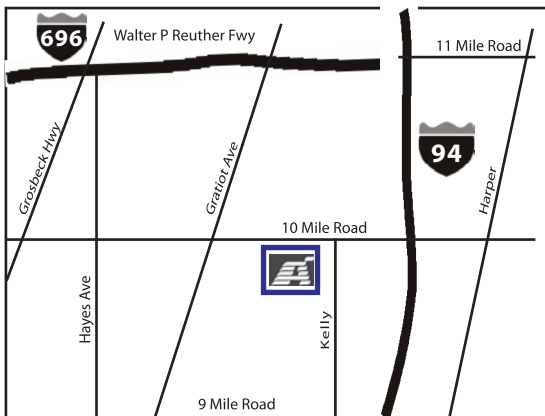

NORTH LIMA KEY CONTACTS

**GENERAL MANAGER
ACCOUNT MANAGER
GENERAL MAILBOX**

**DIANNE BERDINE
GEOFF EVANS**

**DIANNE.BERDINE@ACTIVEFOAM.COM
GEOFF.EVANS@ACTIVEFOAM.COM
NORTHLIMA@ACTIVEFOAM.COM**

**ACTIVE FOAM PRODUCTS, INC.
12037 SOUTH AVE
NORTH LIMA, OH, 44514
TOLL FREE: 800-788-6096
PHONE: 330-629-9454
FAX: 330-629-9455
WEB SITE: WWW.ACTIVEFOAM.COM**



DIANNE BERDINE
General Manager



GEOFF EVANS
Account Manager

Via I-80: Take I-80 East to I-680 South. Take Exit 14, Western Reserve Road towards OH-164. Turn left onto E Western Reserve Road. Immediately turn right onto OH-164/South Avenue. Active Foam is 4 miles down on the left hand side. The building is immediately after the intersection of OH-164 and OH-165.

Via I-76: Take I-76 via the Pennsylvania Turnpike, merge onto Market Street/OH-7 via Exit 232. Continue on OH-7 S to OH-164 S. Turn slight right onto South Avenue/OH-164 S. Active Foam is 1 miles down on the left hand side. The building is immediately after the intersection of OH-164 and OH-165

Via Route 11: Take OH-11 N to OH-344 E toward Leetonia/Columbiana. Turn right onto OH-344 E, at the traffic circle take the 3rd exit onto N Main Street. Take a slight right to stay on N Main Street. Continue onto OH-164 N/South Avenue. Active Foam is 3 miles down on the right, immediately before the intersection of OH-164 and OH-165.

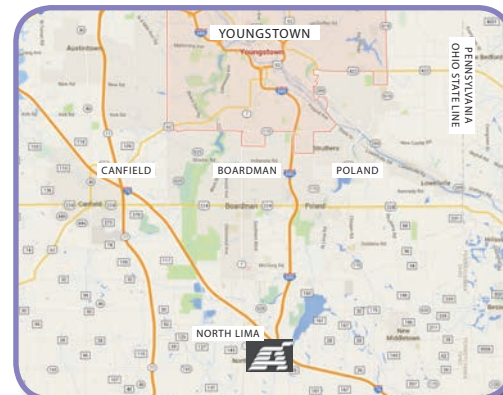
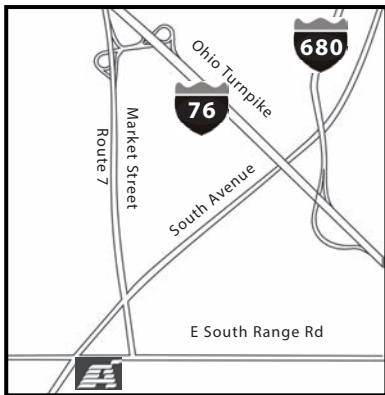

FOAM GUIDE & REFERENCE TABLES

CONVENTIONAL FOAMS

QUALITY	SERIES	FIRMNESS	FOAM NUMBER	COLOR	
ECONOMY	1200	10	SUPER SOFT	CV1210	WHITE
	1200	20	SOFT	CV1220	WHITE
	1200	35	MEDIUM	CV1235	WHITE
ECONOMY PLUS	1500	50	FIRM	CV1550	WHITE
GOOD	1800	18	VERY SOFT	CV1818	WHITE
	1800	25	SOFT	CV1825	WHITE
	1800	30	MEDIUM SOFT	CV1830	WHITE
	1800	35	MEDIUM	CV1835	WHITE
	1800	45	FIRM	CV1845	WHITE
	1800	65	EXTRA FIRM	CV1865	WHITE
	1800	90	EXTRA HARD	CV1890	CHARCOAL
	20100	100	SUPER FIRM	CV20100	WHITE
BETTER	2200	35	MEDIUM	CV2235	LIGHT BLUE
	2200	40	MEDIUM FIRM	CV2240	LIGHT BLUE
	2200	45	FIRM	CV2245	LIGHT BLUE
BETTER PLUS	2500	35	MEDIUM	CV2535	WHITE
	2600	50	FIRM	CV2650	WHITE
	2600	65	EXTRA FIRM	CV2665	WHITE
	2600	80	EXTRA HARD	CV2680	WHITE
	2500	140	SUPER HARD	CV25140	LIGHT BLUE
BEST	2800	35	MEDIUM	CV2835	WHITE
	2800	45	FIRM	CV2845	WHITE
	2800	60	EXTRA FIRM	CV2860	WHITE
	2800	80	EXTRA HARD	CV2880	WHITE
	4400	125	SUPER HARD	CV44125	GREEN
	4000	155	SUPER HARD	CV40155	LT GREEN

REST-EASY "HR" FOAMS

QUALITY	SERIES	FIRMNESS	FOAM NUMBER	COLOR	
BEST	2400	20	SOFT	HR2420	WHITE
BEST	2700	27	MEDIUM SOFT	HR2727	WHITE
BEST	3000	50	FIRM	HR3050	YELLOW
	3000	70	FIRM	HR3070	YELLOW
BEST	3100	33	MEDIUM	HR3133	WHITE

ULTRACEL "HR" FOAMS

QUALITY	SERIES	FIRMNESS	FOAM NUMBER	COLOR	
BETTER	1800	10	SUPER SOFT	HR1810	YELLOW
	1800	20	SOFT	HR1820	YELLOW
	1800	30	MEDIUM SOFT	HR1830	YELLOW
BETTER-PLUS	2500	27	MEDIUM SOFT	HR2527	WHITE
	2500	30	MEDIUM	HR2530	YELLOW
	2500	45	FIRM	HR2545	YELLOW

SPECIALTY FOAMS FOAMS

QUALITY	SERIES	FIRMNESS	FOAM NUMBER	COLOR	
DRY-FAST	4000	25	SOFT	DF4025	NATURAL
		35	MEDIUM	DF4035	NATURAL
		45	FIRM	DF4045	NATURAL
		60	EXTRA FIRM	DF4060	NATURAL
		99	EXTRA HARD	FL4099	NATURAL
FLOTATION LATEX/PINCORE	4500	25	SOFT	PC4525	LIGHT CREAM
		35	MEDIUM	PC4535	LIGHT CREAM
		45	FIRM	PC4545	LIGHT CREAM
BONDED	5000	05	FIRM	BF5005	MULTI
		06	EXTRA FIRM	BF5006	MULTI
		07	EXTRA FIRM	BF5007	MULTI
		10	SUPER HARD	BF5010	MULTI
		10	EXTRA FIRM	BF5106	MULTI
PREMIERE BONDED	5100	08	SUPER HARD	BF5108	MULTI
		09	SUPER HARD	BF5109	MULTI
AUTOMOTIVE	5600	200	VOLARA	VL5610	WHITE
		125	NEOPRENE	NP5620	BLACK
FAR	9600	125	NEOPRENE	NP5630	TAN
		35	MEDIUM	NP5635	PINK

ACTIVE GUIDES

Active Foam Products "Foam Guide" explains how to identify the different foams, and how this information will help you.

The two basic characteristics of a foam are its quality, and its firmness. There are 4 numbers shown. The first two numbers represent the density and quality; the second two numbers represent the firmness. This allows you to custom fit the combination of your choice.

FURNITURE FIRMNESS SCALE

SUPER SOFT	10
	15
SOFT	20
	25
MEDIUM SOFT	30
MEDIUM	35
MEDIUM FIRM	40
	45
FIRM	50
	55
EXTRA FIRM	60
	65
	70
EXTRA HARD	75
	80
	85
SUPER HARD	90
	95
X-SUPER HARD	100

MATTRESS FIRMNESS SCALE

SUPER SOFT	10
	15
	20
MEDIUM SOFT	25
MEDIUM	30
FIRM	35
	40
EXTRA FIRM	45
	50
SUPER FIRM	55
	60
	65
	70
	75
	80
	85
	90
	95
	100



QUALITY SCALE

RATING SCALE	UTILITY OK	GOOD	BETTER	BEST
	3	6	8	10
	4	7	9	
	5	8		
	6	9		
	7	10		

The more urethane foam contains, the better the foam performs.

WHEN QUALITY INCREASES YOU GAIN:

- Quality feel
- Comfort and springiness
- Bouncy support
- Longevity of firmness
- Longevity of shape
- Longevity of support
- Satisfied customers

FOAM GUIDE & REFERENCE TABLES

FIRMNESS CROSS REFERENCE CHART

	1200	1500	1800	2000	2200	2600	2800	U-HR	R-HR	4000	4500	5000	5100
SUPER SOFT	1210							1810		4010			
VERY SOFT			1818										
SOFT	1220		1825					1820	2420	4025	4525		
MED-SOFT			1830					1830					
MED-SOFT								2527	2727				
MEDIUM	1235		1835		2235	2535	2835	2530	3133	4035	4535		
MED-FIRM					2240								
FIRM		1550	1845		2245	2650	2845	2545	3050	4045	4545		
FIRM			1855										
EXTRA FIRM			1865			2665	2860			4060			5106
EXTRA HARD			1890				2880		3070			5007	5108
SUPER HARD				20100		25140	44125						5109
SUPER HARD							40155			4099		5010	

ALL FOAMS COMPLY WITH CALIFORNIA TB #117-2013 & CertiPUR-US

CV1210	CV1865	CV25140	HR1830	HR3070
CV1220	CV1880	CV2535	HR2527	VE4010
CV1235	CV1890	CV2650	HR2530	DF4025
CV1550	CV20100	CV2665	HR2545	DF4035
CV1818	CV2235	CV2835	HR2420	DF4045
CV1820	CV2240	CV2845	HR2727	DF4060
CV1830	CV2245	CV2860	HR2850	CV40155
CV 1835	CV2535	CV2880	HR2870	CV44125
CV1845	CV2650	HR1810	HR3133	
CV1855	CV2665	HR1820	HR3050	

ALL COMPLY WITH CALIFORNIA TB #117-2013, MVSS-302, CertiPUR-US

HR2727
HR2735
HR2745
HR3050
HR3070

WARNING! FOAM BURNS

Urethane foam is an excellent and versatile cushioning product. As with many products, however, you need to be aware of potential dangers associated with foam. Incorrect storage or handling of urethane foam may result in fire. For that reason we recommend that you discuss appropriate storage and handling methods with your fire insurance underwriters. We encourage you to provide appropriate warnings regarding urethane foam to your customers, the ultimate user of your product and your employees. Your legal department should review any warnings you provide.

In addition to our conventional foam product, Active Foam Products sells a broad line of combustible modified foams which can pass the following test*.

California Technical Bulletin 117-2000
California Technical Bulletin 117-2013
California Technical Bulletin 133
F.A.A. Seat Cushion Requirements--
Airworthiness Standards, Section 25.853(a)

Boston Fire Department Seating Test
British Standard 5852:Part 2:Crib 5
UFAC Current Standards as of 9-81
IMO A.652(16)-Smoldering Cigarette & Butane Flame
Port Authority of NY and NJ Padding and Cushioning

ASTM E-162-79-1"
MVSS-302
NFPA 260
ASTM D-3675-1"
UL-94 (Meets 94HF1)

THESE TESTS WERE PERFORMED UNDER CONTROLLED LABORATORY CONDITIONS AND MEET SPECIFIC TEST REQUIREMENTS. THESE TESTS ARE NOT INTENDED TO REFLECT THE PERFORMANCE OF THIS COMPONENT PRODUCT OR ANY OTHER MATERIAL UNDER ACTUAL FIRE CONDITIONS. THE USE OF THIS COMPONENT PRODUCT IN A FINISHED PRODUCT DOES NOT MEAN THAT THE FINISHED PRODUCT WOULD NECESSARILY MEET THE TEST REQUIREMENTS AND DOES NOT MEAN THAT THE FINISHED PRODUCT WILL NOT BURN. DUE TO THE GREAT NUMBER AND VARIETY OF APPLICATIONS FOR WHICH THIS PRODUCT IS PURCHASED, WE DO NOT RECOMMEND SPECIFIC APPLICATIONS OR PRODUCT DESIGNS OR ASSUME RESPONSIBILITY FOR USE RESULTS OBTAINED OR SUITABILITY FOR SPECIFIC APPLICATIONS.

THE RIGHT FOAM IS A QUESTION AWAY

Every year we fabricate foam for hundreds of varied applications. Getting the right foam for your application & budget is very important to your success in making your customers happy with your work. Our experience from over 60 years of fabricating can make your job a great deal easier and more effective.

These are some of the most frequently asked questions about your non day-to-day foam applications. Listed below are just a few suggestions. The suggestions are certainly not all that can be used, but a good point to start. For some applications there is absolutely one foam that is "the foam" to use. For other applications there are several good interchangeable suggestions and your budget will likely define your choice.

Many unique applications may require our experience to suggest the best choices because of our technical understanding of the many foams we fabricate. Call us for our technical expertise and vast experience.

Additionally, we stock more foams that are not listed in the catalog. Because we fabricate foam for many non-furniture industries, we don't list those that don't have relevance to the furniture, automotive, and marine markets in this catalog. So if you have a unique application outside these markets, there is still a great chance that we can help you in those areas as well.

Give us a call. We're here to help you with your everyday foam needs and those unique applications.

FOAM APPLICATION SUGGESTIONS



MOTORCYCLE SEATS

HR3070, CV44125, BF5010



GYM & KARATE MATS

FL4099, 5010 10lb Bonded,



2" WINDOW SEATS

CV1845, CV2245, HR2545, CV2845, CV2650, CV2665, CV2860, CV2880



FRONT RAIL WEDGE

BF5010 10lb Bonded



THERAPY TABLES

BF5007, BF5010, BF5106, BF5108, HR3050, HR3070



TRUCK DOCK SEALS

CV1235, CV1550



INSULATION INSERT

PE5720 PE Wrap, CV1235



SPA COVERS

PE5517, PE5520, CV1890



OTTOMANS

CV1865, CV2665, CV2860, CV2880, HR3050, HR3070



CHURCH PEWS

CV1845, CV2245, HR2545, CV2650, CV2665, CV2845, CV2860, CV2880



CHURCH KNEELERS

5010 10lb Bonded



CAMPER SLEEPERS

CV1835, CV2235, CV2240, CV2535, HR2530



DOWN CUSHION W/CORE

HR1810, CV1818, HR1820, HR2420, HR2527



WHEELCHAIR PADS

CONFOR FOAMS, FL4099, VE4010, VG6810



Bar Rails

BF5108, BF5109, BF5010, CV2860, CV2880, HR3050, HR3070



Ball-Park Walls & Fences

CV1550, CV1865, CV1890, PE5517, PE5520



SOUND PANELS

PS5420 Flat, PS5422 Convuluted



Truck Seat Toppers

CV2245, HR2545, CV2650, CV2665, CV2845, CV2860, CV2880, HR3050, HR3070

FOAM "ID BADGE" EXPLANATION

FIRMNESS

It is in terms of "IFD" or "ILD" which stands for Indention Load Deflection. Basically it measures how much weight it takes to compress foam a certain amount. The "Firmness" or "Compression" of a foam normally ranges between 10 to 100. The higher the number the firmer the foam. The scale on the "Foam ID" should help you understand the number system normally measured

FOAM NUMBER

This is a four digit I.D. number that every foam has. For all conventional and HR foams the code represents the foam's density & firmness. The first two numbers represent its density. The second two numbers represents its firmness.

FOAM TYPE

Since most of the foams we fabricate are some type of a urethane foam manufactured for furniture, we have differentiated them into their major distinctions. Understanding their differences can help you tremendously in clarifying and choosing the right foam for your job.

FOAM COLOR

Many furniture grade foams are Color Coded for easy site recognition. Several formulas are run in two different colors because of differing requirements. So please be aware that the listed color is not a guarantee. If it is vital for your application, please let us confirm the current color stock.

QUALITY RATING

This is an overall rating of the foam's qualities in relationship to its performance & durability. There are many characteristics of a foam. The list of all the variables and characteristics are far too long, and are best left to the chemists who formulate the foams. In the end, it is the foam's overall performance that matters most to you. Therefore we have synthesized an overall rating that is indicative of the foams quality to assist you in visually comparing different foams.

FIRE RETARDENT FOAMS

All foams will burn. The important matter is how slow it will burn & smoke. There are over 200 different codes in a most fractured and varied system. However, there are really only a few codes that in practice get tested for and used. When you have an application that requires a fire retardant foam, there must be a code that is being requested for the foam or the piece of furniture to meet. There is no such thing as Fire Retardant Foam unless you have a specific code. The codes we have listed: 117-13 = California TB 117-2013, 302 = Motor Vehicle Safety Standard 302 (MVSS 302), 133 = California TB 133 (*it is not a foam code, but a full scale burn test of a piece of furniture), FAR = Federal Aviation Regulations (* there are many), and Other = the many other that specifiers will request.

DENSITY

The weight of a cubic foot of foam. Although there are many other factors, Density is considered to be the most important indicator of overall foam quality. High density polyurethane is less likely to "bottom out", fatigue, or dish. There are exceptions, but as rule of thumb, the higher the density within a given type of foam, the better the quality. The Heavier, the Better.

SUPPORT FACTOR

The ratio of a foam's firmness when it is 65% compressed, to when it is 25% compressed. In English, it is a number that represents how fast a foam gets firmer as you compress it. The higher the number, the greater the difference between the surface firmness and the deep-down support. Initially, two foams may feel the same on compressing them from 4" down to 3", but may feel different when fully compressed down to 1.5". All foams get firmer the more they are compressed. Some foams get firmer faster. The higher the number, the firmer it will get. The range is mainly between 1.8 times its original firmness to 2.5 times its original firmness. Understanding what a Support Factor represents, can help in understanding why some foams work better in certain applications than others. Higher Support Factors allow desirable surface softness and firm inner support.

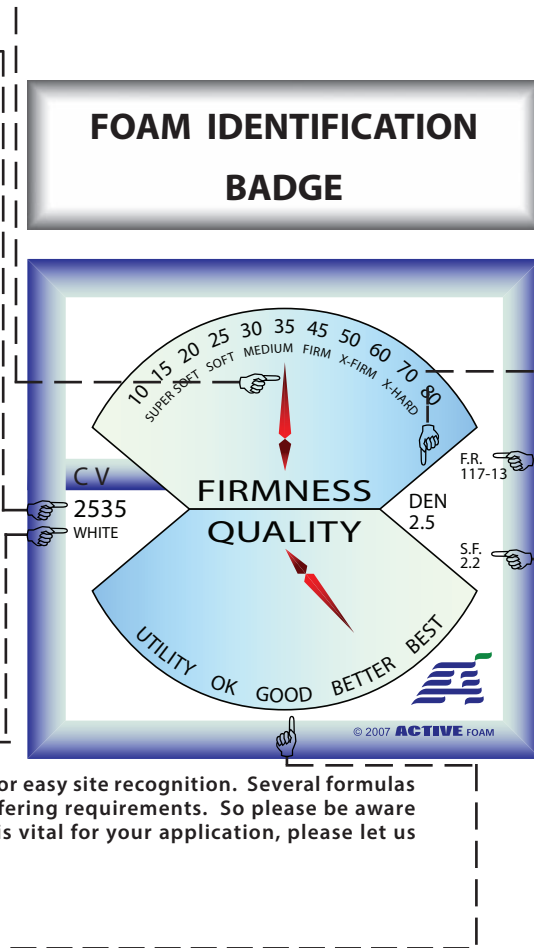

PREFIXES

- BF Bonded Foams
- CF Confor Foams
- CV Conventional Foams
- CM Combustion Modified meeting more stringent standards.
- DF Dry Fast Foams
- EP Expanded Polystyrene (Styro Foam)
- FL Flotation Foam
- FR Fire Retardant to MVSS-302
- HC High Comfort Foams
- HR High Resilient Foams
- NP Neoprene Foams
- PC Pincore - Latex
- VE Visco-Elastic Foam
- VL Volara Cross Link Foam
- XL Cross Link Foams



FOAMS THAT FEEL GOOD AND YOU CAN FEEL GOOD ABOUT

CERTIPUR-US® CERTIFIED FOAMS COME WITH COMFORT AND CONFIDENCE

If you are part of the growing movement of consumers who want to know all you can about the items you buy for yourself, your family and your home, you'll take comfort in knowing that home furnishings carrying the CertiPUR-US® seal contain flexible polyurethane foam cushioning products that have been tested and certified by independent laboratories.

CertiPUR-US® is like having a health check-up for foam. The foam is examined and put through a series of scientific tests to be sure it meets the strict voluntary standards of the CertiPUR-US® program. The tests evaluate foam content and important durability factors.

The CertiPUR-US® program is administered by a not-for-profit organization and is the most rigorous and comprehensive certification for polyurethane foam.

ABOUT CERTIPUR-US®

The CertiPUR-US® program is a voluntary testing, analysis and certification program for flexible polyurethane foam used as a cushioning material in home furnishings such as adult mattresses, crib mattresses, upholstered furniture and some accessory comfort products. Certified flexible polyurethane foams have been independently laboratory tested and certified to be:

- Made without ozone depleters
- Made without PBDE flame retardants
- Made without mercury, lead and other heavy metals
- Made without formaldehyde
- Made without phthalates regulated by the Consumer Product Safety Commission
- Low VOC (Volatile Organic Compound) emissions for indoor air quality (less than 0.5 parts per million)
- Tested and approved for durability and performance.

The CertiPUR-US® program is administered by a not-for-profit organization and is the most rigorous and comprehensive certification for polyurethane foam.

WHY IS CERTIFICATION IMPORTANT?

Responsible foam suppliers here in the U.S. were concerned that there was no way for consumers to know what was inside foam products used in bedding and upholstered furniture.

Today, U.S. and foreign foam suppliers may participate in the program, as long as they meet the rigorous certification GUIDELINES.



Be sure about
the foam in
your home.

[Learn more in this :90 video](#)

BASED ON GOOD SCIENCE AND DEVELOPED IN COOPERATION WITH ENVIRONMENTALISTS

The certification process was developed by the foam industry in close collaboration with leading environmentalists, chemists, accredited laboratory research scientists and bedding and furniture industry leaders. CertiPUR-US® emissions and analysis methods are compatible with other standards such as Eco-label (EU), LGA (Germany), OekoTex 100 (Class IV Mattress) EUI, Blue Angel (Netherlands), IKEA, AQS Greenlabel and BIFMA criteria.

TRANSPARENCY

The technical guidelines and testing requirements for the CertiPUR-US® program are “living” documents, allowing for transparent revisions based on relevant scientific findings and new health, environmental and safety regulations. The CertiPUR-US® certification is based on the established U.S. Voluntary Physical Performance and Environmental Guidelines for Prime Flexible Polyurethane Foam for Use in Furniture and Bedding (PDF). The Guidelines set baseline criteria for product physical performance, component analysis, and product emissions evaluation and were developed to meet or exceed guidelines established by the CertiPUR®* program and REACH, a European system of regulation for chemicals and their safe use that deals with registration, evaluation, authorization and restriction of chemical substances.

* CertiPUR-US® is adapted from, and closely aligned with, the European CertiPUR program, developed in 2002 by EUROPUR, the association of European flexible polyurethane foam block manufacturers. One key difference is that the CertiPUR-US® program includes physical performance standards that help quantify durability, consistency, and comfort.

PRODUCT VERIFICATION AND USE OF THE SEAL

We have an aggressive program in place to monitor the use of the CertiPUR-US® mark and to conduct random samples of certified products for verification purposes. The integrity of the program and its value to participating companies will be enhanced through vigilant protection. We emphasize transparency so that we continue to earn consumers' confidence.



CertiPUR-US® is a program of the Alliance for Flexible Polyurethane Foam, an organization formed in 1995 and incorporated in 2008. In addition to administering the CertiPUR-US® certification program, the mission of AFPF to educate consumers as well as the industry about the benefits of flexible polyurethane foam.

Foam adds comfort to our homes.

CertiPUR-US® is a registered certification mark of Alliance for Flexible Polyurethane Foam,

For more complete information, visit the CertiPUR-US® website: <http://certipur.us/pages>

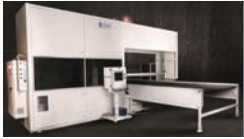

FOAM FABRICATING



**CONCEPTUAL DRAWINGS:
3-AXIS MOTORCYCLE SEATS**

A block of HR3070, typical for automotive seating, is used to create the side profile of the seat on a vertical CNC machine.

The finished piece

Alternately, the seat edges may then be sculpted by hand with our foam sculpting discs as shown in this example. (Page 146)

The block is then rotated 90° with the profile remaining inside, and cut again using the second drawing.

**CONCEPTUAL DRAWINGS:
3-AXIS HEADREST WITH A
LAMINATED VISCO ELASTIC LAYER**

A block of HR2545 is used to cut the profile for the base of the headrest on a vertical CNC machine.

The finished piece

The layer of Visco Elastic foam is then laminated with Kwik-Spray #860 adhesive to the top of the base, and a second pattern is cut.

**CONCEPTUAL DRAWINGS:
CURVED AND CONTOURED MARINE SEAT**

We start by cutting the contoured profile of the seat from a block of CV2650 on a horizontal CNC machine.

Since the profile is square in length, it is then taken to a vertical blade where foam is trimmed from the back to create a short curve, and slitted for more foam to fit into the front to fashion a longer curve.

Lastly, the back notches are glued together, and foam "darts" are inserted and adhered in the front to make the finished piece.

THE FOAMING PROCESS

DIAGRAM I

This is a foam pouring line. The chemicals are pumped from the "Tank Farm" through a mixing head into a trough which dispenses the foam batter onto the conveyor. This process is controlled by sophisticated computers that take into account many variables. Each foam type has its own recipe. The foam batter is initially one inch thick and rises up to 40 inches after traveling about 30 feet down the line, in a time of about 3 minutes. The height and the speed of all the processes depend on the formula being poured.

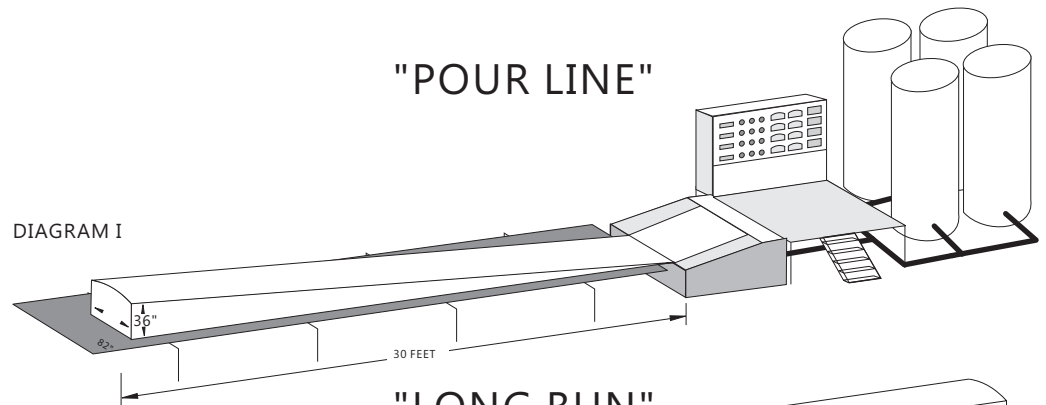

DIAGRAM II

"Long-Bun". The foam moves down the conveyor belt in one long continuous bun, until a blade cuts it and separates it from the ongoing foam that is being produced. This is what is known as a "Long-Bun". "Long Buns" are typically 200 feet long, and can run up to 300 feet in length. A large crane then lifts this tremendous piece of foam and stacks it on other "Long Buns" to cure for 24 hours. The temperature of the foam during the curing process rises up to 350 degrees. The "Mill's" focus is on the manufacturing of "Long Buns" and the distribution of them in the form of "Buns".

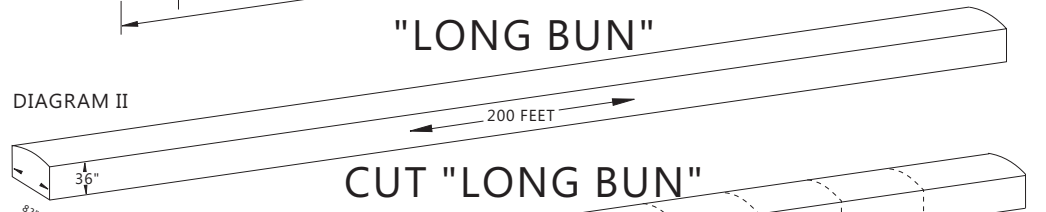

DIAGRAM III

Active Foam (a fabricator) will then give the "Mill" instructions to specific "Bun" sizes of each particular foam type. The "Pour Width" typically becomes the "Bun Length", or your "Sheet Length". On popular foams Active Foam typically orders an entire "Long Bun". On slower moving foams and specialty foams Active Foam might order a half of a "Long Bun", or just a "Bun" or two.



DIAGRAM IV

"Bun Stock". "Buns" are the form in which a fabricator purchases and stocks. Active Foam carries various sizes to accommodate the sheet sizes and cut parts to keep the waste down. Having the correct "Bun" size is crucial to getting a good yield, which means keeping costs and the scrap pile down.

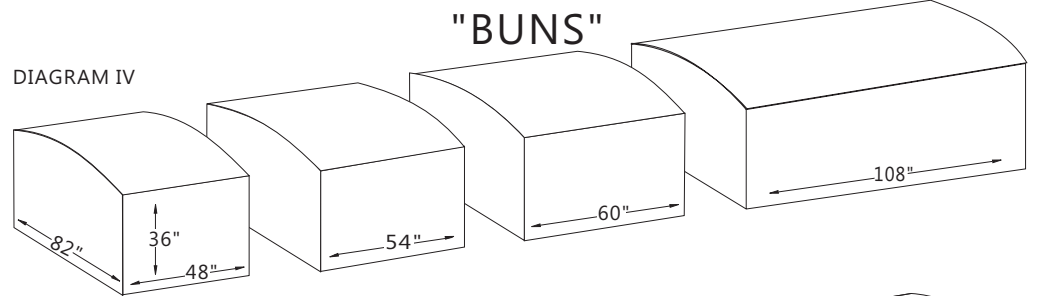

DIAGRAM V

This diagram shows how our "Cutter" goes about planning and cutting "Sheet" sizes from the various widths of "Bun Stock". Active Foam cuts up Bun Stock in what are called "Half Buns". The "Half Buns" are cut to the widths of standard sheets. This allows for a quick shipping time even when fabricating foam to order. Yes, Active Foam can cut to any specified incremental thicknesses. Active Foam's price list shows prices only in one inch increments, although sheets can be cut to 1/8" increments.

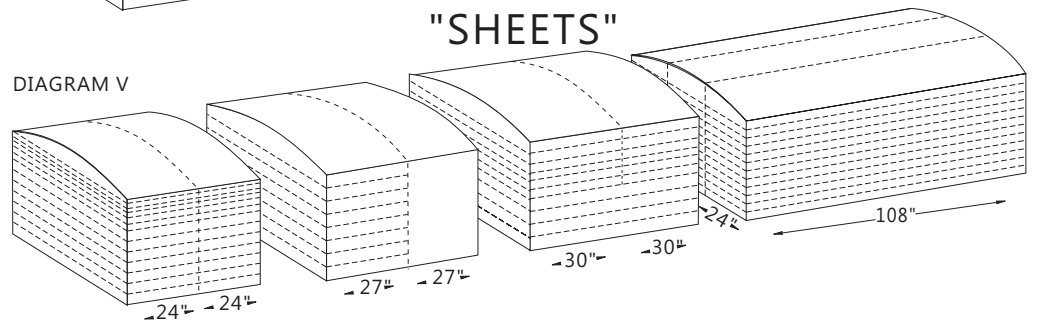
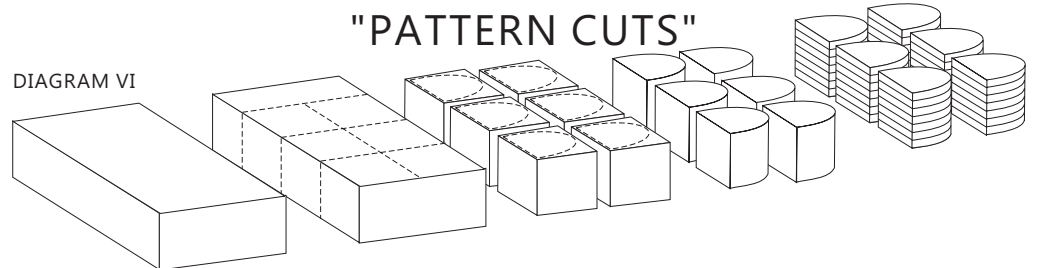

DIAGRAM VI

This demonstrates how our "Cutter" goes about setting up and cutting your pattern pieces. First, a "Bun Cut" is made that will yield all or part of your pieces. Secondly, the "Bun Cut" is blocked to best fit the pattern. Thirdly, the patterns are traced. Fourthly, the "Blocks" are cut to the pattern on the "Vertical Cutter". Lastly, the patterned pieces then get sent to the "Horizontal Slitter" to be sliced up like bread to get them down to your specified thickness.



FOAM GLOSSARY

AIR FLOW	The Air Flow test measures the ease with which air passes through a foam. It is also an excellent measure of the overall efficiency with which the foam was produced.
BALL REBOUND	A laboratory test used to measure surface resiliency. A steel ball is dropped from a fixed height and the percentage of Ball Rebound determines the resilience value (See Resiliency).
BOARDY	An undesirable stiff surface feel found in some foams with high 25% IFD values (See Hand).
BOTTOM OUT	Lack of support under full weight load. This characteristic is often found in low-density foam. The problem can be reduced by increasing density to achieve an adequate Support Factor.
BREATHABILITY	(See Air Flow)
COMFORT FACTOR	(See Support Factor)
COMPRESSION MODULUS	(See Support Factor)
COMPRESSION SET	Foam with poor Compression Set may quickly exhibit an undesirable appearance often described as "taking a set." In a cushion, mattress core, or with innerspring mattress padding, the result is noticeable as a permanent surface depression which may eventually affect upholstery cover fit. Foam cushioning is tested for Compression Set in the lab by compressing a foam sample down to 90% of its thickness and holding it in that compressed position at above average temperature for 22 hours.
CONVOLUTED	A foam fabrication process involving the use of special cutting equipment to produce a foam sheet with "egg carton" dimples. The base under the dimples can be varied in thickness. Peaks can be produced from 1/2" to over 4" in height. A convoluted topper pad can be laminated to a cushion or mattress core for added surface softness and retail sales appeal.
DENSITY	The weight of a cubic foot of foam. Density is independent from firmness. Although foam production conditions can adversely affect the grade of flexible polyurethane, Density is considered to be the most important indicator of overall foam quality. High density polyurethane is less likely to "bottom out", "fatigue" or "dish". Higher Density virgin foam cores can be designed to provide plush surface softness without sacrificing deep-down support.
DISH	An undesirable characteristic that sometimes occurs when weight is placed in the center of a foam mattress and the corners rise and bow in response to the deep compression. This hammock-effect can cause bed covers to pull loose. Dish can be minimized by specifying cores with higher density.
FATIGUE (FLEX FATIGUE)	A softening or loss of firmness. A condition which often causes complaints with upholstered furniture, and with some foam mattresses. Fatigue can be measured in the laboratory by repeatedly compressing a foam sample and measuring the change in IFD.
FILLED FOAM	The addition of heavy, inert materials such as marble dust or clay, to increase the density. The additional filler weight can reduce the "dish" effect. Many fillers also increase the Support Factor. Filled polyurethane foam may be inappropriate for some applications, if the polymer content of the filled foam is not sufficient for the intended application before fillers are added. Filled foams with low polymer content or a high percentage of filler material tend to have less resiliency, strength and durability.
FINGER NAIL	Occurs when a foam core has been improperly produced. Finger Nail can be tested by pressing a finger nail into a foam sample. A definite impression that does not quickly recover indicates the foam will be boardy and have a stiff surface feel.
HAND	Is the feel of the foam as the hand is rubbed lightly over the surface. If the foam has a stiff or hard feel to the touch, it is described as having a poor Hand. Foam with a good Hand has a springy, velvet feel which is appealing to customers.

FOAM GLOSSARY

HARDNESS RATIO	(See Support Factor)
HIGH RESILIENCE (HR)	A premium variety of polyurethane foam produced using a blend of polymer or graft polyols. High Resilience foam has a cell structure different from conventional products. The different cell structure helps add support, comfort and durability. High Resilience foams have a high Support Factor which describes the relationship of surface comfort to deep-down support. High Resilience foam is primarily sold at high density levels. HR foam is considered to be a very high quality material for use in upholstered furniture and mattresses.
HYSTERESIS	The ability of foam to maintain original support characteristics after flexing. Hysteresis is the percent of 25% IFD loss measured as a compression tester returns to the normal (25% IFD) position after measuring 65% compression. Higher Hysteresis values, or less IFD loss, are desirable. Current research indicates that Hysteresis values may provide a good indication of overall flexible foam durability.
IFD INDENTATION FORCE DEFLECTION	Is a measure of load bearing capacity or firmness. IFD is measured on the surface as 25% IFD, and under full load bearing conditions as 65% IFD. For example, to determine 25% IFD, a four-inch thick foam sample is compressed to three-inch thickness. The number of pounds required to achieve compression is the 25% IFD value. The 65% IFD reading is obtained in the same way at deeper compression (65% of the sample thickness). The higher the 25% IFD, the firmer the surface feel. Foams with higher 65% IFD values resist bottoming-out and provide a firm ride in cushioning. Ideal IFD specifications will depend upon the application.
ILD INDENTATION LOAD DEFLECTION	(See IFD)
LAMINATION	A fabrication process which bonds one foam variety to another using durable adhesives. Lamination can be used to combine foam slabs with differing firmnesses and densities to obtain desired combinations of comfort and support.
LATEX	A natural foam rubber product which is not related to polyurethane foam.
LOADED	(See Filled Foam)
MOLDED FOAM	Chemicals are poured into a mold to form a cushion or mattress core with unique surface contours. The molding process does not greatly affect the performance of the foam, but can help to visually enhance a product line.
POLYMERIC	(See High Resilience)
REINFORCED	(See Filled Foam)
RESILIENCY	Surface liveliness and spring-back ability. Measured in the lab with a Ball Rebound test. A steel ball is dropped onto the foam sample from a fixed height. Resilience is expressed as a percentage of ball rebound against the original height of the ball drop. A boardy foam will have low Resilience. Foam cushioning Resilience values range from 40 to 75%.
SHINERS	Light reflected from intact cell walls in the foam. These are noticeable on cut surfaces of foam. Too many Shiners indicate a foam that has too many closed cells and therefore would have a poor Air Flow value. They result from too much catalyst during the foam production.
SUPPORT FACTOR	The ratio of 65% IFD divided by 25% IFD. The higher the number, the greater the difference between the surface firmness and the deep-down support. Support Factor is the best means of measuring comfort for comparison purposes. Higher Support Factors allow desirable surface softness and firm inner support.



Quality Foam Sold Here!

As a Fabricator of over 60
Foams, we know that foam is
not just foam. It is our goal
to carry Good & Consistent
Foams at each Quality Range.

© 2007 ACTIVE FOAM

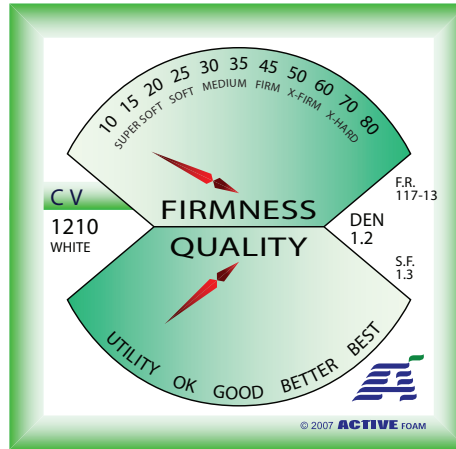

© 2007 ACTIVE FOAM

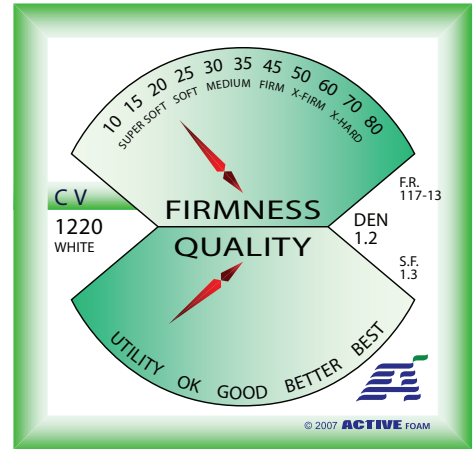

© 2007 ACTIVE FOAM

FOUR LEVEL PRICING

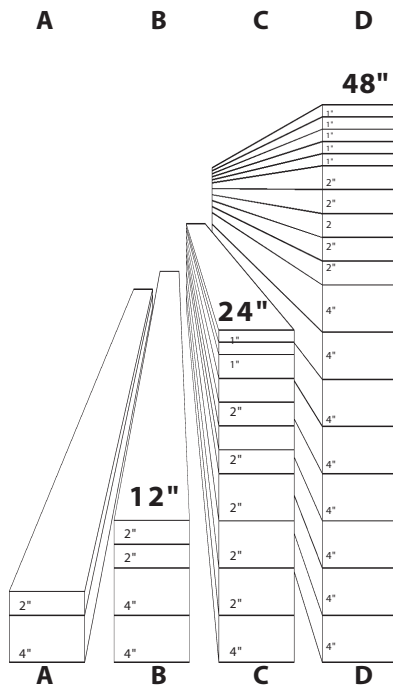

Pricing on foam is based on the quantity purchased. The first level, "A PRICING", is on purchases less than 12" of total height. To reach the second pricing level, "B PRICING", a total of 12" must be purchased of a single foam type. An example: 2 sheets of #2235 4"x24"x82" & 2 sheets of #2235 2"x30"x82" would equal 12"s. If the order was doubled, the total height would be 24" reaching the third level, "C PRICING". Level four, "D PRICING" is the top pricing level that can be reached on a total height of 48".

For Thickness not listed here, Pricing is proportionally based and Volume Discounts apply. Upcharge may apply to thicknesses less than one inch.

CV1210 SUPER SOFT

24" x 82"

SIZES	A	B	C	D
1"	24.40	21.70	20.20	19.40
1½"	36.60	32.60	30.30	29.10
2"	48.80	43.40	40.40	38.80
2½"	61.00	54.30	50.50	48.50
3"	73.20	65.10	60.60	58.20
3½"	85.40	76.00	70.70	67.90
4"	97.60	86.80	80.80	77.60
4½"	109.80	97.70	90.90	87.30
5"	122.00	108.50	101.00	97.00
5½"	134.20	119.40	111.10	106.70
6"	146.40	130.20	121.20	116.40
7"	170.80	151.90	141.40	135.80

48" x 82"

SIZES	A	B	C	D
1"	48.80	43.40	40.40	38.80
1½"	73.20	65.10	60.60	58.20
2"	97.60	86.80	80.80	77.60
2½"	122.00	108.50	101.00	97.00
3"	146.40	130.20	121.20	116.40
3½"	170.80	151.90	141.40	135.80
4"	195.20	173.60	161.60	155.20
4½"	219.60	195.30	181.80	174.60
5"	244.00	217.00	202.00	194.00
5½"	268.40	238.70	222.20	213.40
6"	292.80	260.40	242.40	232.80
7"	341.60	303.80	282.80	271.60

60" x 82"

SIZES	A	B	C	D
1"	61.00	54.30	50.50	48.50
1½"	91.50	81.40	75.80	72.80
2"	122.00	108.50	101.00	97.00
2½"	152.50	135.70	126.30	121.30
3"	183.00	162.80	151.50	145.50
3½"	213.50	189.90	176.80	169.80
4"	244.00	217.00	202.00	194.00
4½"	274.50	244.20	227.30	218.30
5"	305.00	271.30	252.50	242.50
5½"	335.50	298.40	277.80	266.80
6"	366.00	325.50	303.00	291.00
7"	427.00	379.80	353.50	339.50

CV1220 SOFT

24" x 82"

SIZES	A	B	C	D
1"	24.40	21.70	20.20	19.40
1½"	36.60	32.60	30.30	29.10
2"	48.80	43.40	40.40	38.80
2½"	61.00	54.30	50.50	48.50
3"	73.20	65.10	60.60	58.20
3½"	85.40	76.00	70.70	67.90
4"	97.60	86.80	80.80	77.60
4½"	109.80	97.70	90.90	87.30
5"	122.00	108.50	101.00	97.00
5½"	134.20	119.40	111.10	106.70
6"	146.40	130.20	121.20	116.40
7"	170.80	151.90	141.40	135.80

48" x 82"

SIZES	A	B	C	D
1"	48.80	43.40	40.40	38.80
1½"	73.20	65.10	60.60	58.20
2"	97.60	86.80	80.80	77.60
2½"	122.00	108.50	101.00	97.00
3"	146.40	130.20	121.20	116.40
3½"	170.80	151.90	141.40	135.80
4"	195.20	173.60	161.60	155.20
4½"	219.60	195.30	181.80	174.60
5"	244.00	217.00	202.00	194.00
5½"	268.40	238.70	222.20	213.40
6"	292.80	260.40	242.40	232.80
7"	341.60	303.80	282.80	271.60

60" x 82"

SIZES	A	B	C	D
1"	61.00	54.30	50.50	48.50
1½"	91.50	81.40	75.80	72.80
2"	122.00	108.50	101.00	97.00
2½"	152.50	135.70	126.30	121.30
3"	183.00	162.80	151.50	145.50
3½"	213.50	189.90	176.80	169.80
4"	244.00	217.00	202.00	194.00
4½"	274.50	244.20	227.30	218.30
5"	305.00	271.30	252.50	242.50
5½"	335.50	298.40	277.80	266.80
6"	366.00	325.50	303.00	291.00
7"	427.00	379.80	353.50	339.50

What are FR-Codes: Cal.#117-2013 & MVSS-302?

- Cal.#117 refers to the furniture regulation "Technical Bulletin #117-2013" of the California State Fire Marshall Bureau of Home Furnishings. It superseded TB Cal #117-2000. All Furniture in the State of California must minimally meet the criteria set forth in this regulation.
- MVSS 302 refers to the automotive regulation "Federal Motor Vehicle Safety Standard 302". It covers the flammability of interior materials of passenger cars, multipurpose passenger vehicles, trucks, and buses.
- To determine whether you must meet either of these two regulations, you should consult those governing bodies; there are more stringent regulations that you may have to meet.

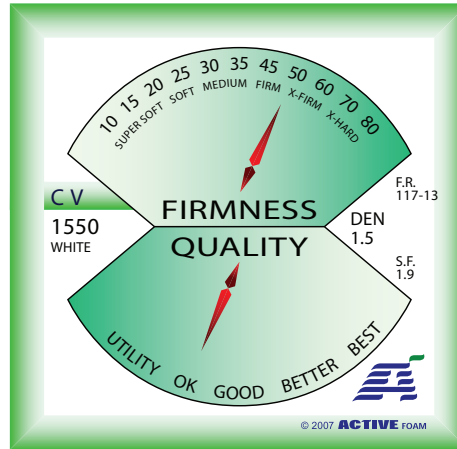
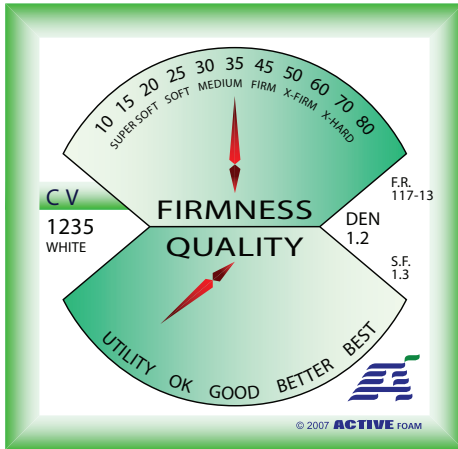

FOAMS THAT FEEL GOOD AND YOU CAN FEEL GOOD ABOUT

- Made without ozone depleters
- Made without PBDE flame retardants
- Made without mercury, lead and other heavy metals
- Made without formaldehyde
- Made without phthalates regulated by the Consumer Product Safety Commission
- Low VOC (Volatile Organic Compounds) emissions for indoor air quality
- Tested and approved for durability and performance.
More Information is on Pages 12-13.

For the most complete resource on CertiPUR-US® go to <http://certipur.us>

CV1235 MEDIUM

24" x 82"

SIZES	A	B	C	D
1"	24.40	21.70	20.20	19.40
1½"	36.60	32.60	30.30	29.10
2"	48.80	43.40	40.40	38.80
2½"	61.00	54.30	50.50	48.50
3"	73.20	65.10	60.60	58.20
3½"	85.40	76.00	70.70	67.90
4"	97.60	86.80	80.80	77.60
4½"	109.80	97.70	90.90	87.30
5"	122.00	108.50	101.00	97.00
5½"	134.20	119.40	111.10	106.70
6"	146.40	130.20	121.20	116.40
7"	170.80	151.90	141.40	135.80

48" x 82"

1"	48.80	43.40	40.40	38.80
1½"	73.20	65.10	60.60	58.20
2"	97.60	86.80	80.80	77.60
2½"	122.00	108.50	101.00	97.00
3"	146.40	130.20	121.20	116.40
3½"	170.80	151.90	141.40	135.80
4"	195.20	173.60	161.60	155.20
4½"	219.60	195.30	181.80	174.60
5"	244.00	217.00	202.00	194.00
5½"	268.40	238.70	222.20	213.40
6"	292.80	260.40	242.40	232.80
7"	341.60	303.80	282.80	271.60

60" x 82"

1"	61.00	54.30	50.50	48.50
1½"	91.50	81.40	75.80	72.80
2"	122.00	108.50	101.00	97.00
2½"	152.50	135.70	126.30	121.30
3"	183.00	162.80	151.50	145.50
3½"	213.50	189.90	176.80	169.80
4"	244.00	217.00	202.00	194.00
4½"	274.50	244.20	227.30	218.30
5"	305.00	271.30	252.50	242.50
5½"	335.50	298.40	277.80	266.80
6"	366.00	325.50	303.00	291.00
7"	427.00	379.80	353.50	339.50

CV1550 FIRM

24" x 82"

SIZES	A	B	C	D
1"	27.10	25.00	24.00	22.10
1½"	40.70	37.50	36.00	33.20
2"	54.20	50.00	48.00	44.20
2½"	67.80	62.50	60.00	55.30
3"	81.30	75.00	72.00	66.30
3½"	94.90	87.50	84.00	77.40
4"	108.40	100.00	96.00	88.40
4½"	122.00	112.50	108.00	99.50
5"	135.50	125.00	120.00	110.50
5½"	149.10	137.50	132.00	121.60
6"	162.60	150.00	144.00	132.60
7"	189.70	175.00	168.00	154.70

60" x 82"

1"	67.80	62.50	60.00	55.30
1½"	101.70	93.80	90.00	82.90
2"	135.50	125.00	120.00	110.50
2½"	169.40	156.30	150.00	138.20
3"	203.30	187.50	180.00	165.80
3½"	237.20	218.80	210.00	193.40
4"	271.00	250.00	240.00	221.00
4½"	304.90	281.30	270.00	248.70
5"	338.80	312.50	300.00	276.30
5½"	372.70	343.80	330.00	303.90
6"	406.50	375.00	360.00	331.50
7"	474.30	437.50	420.00	386.80

WARNING

URETHANE FOAM IS FLAMMABLE!

DO NOT EXPOSE URETHANE FOAMS TO OPEN FLAMES OR ANY OTHER DIRECT OR INDIRECT HIGH TEMPERATURE IGNITION SOURCES SUCH AS BURNING OPERATIONS, WELDING, BURNING CIGARETTES, SPACE HEATERS OR NAKED LIGHTS. ONCE IGNITED, URETHANE FOAMS WILL BURN RAPIDLY, RELEASING GREAT HEAT AND CONSUMING OXYGEN AT A HIGH RATE. IN AN ENCLOSED SPACE THE RESULTING DEFICIENCY OF OXYGEN WILL PRESENT A DANGER OF SUFFOCATION TO THE OCCUPANTS. HAZARDOUS GASES RELEASED BY THE BURNING FOAM CAN LEAD TO INCAPACITATION OR BE FATAL TO HUMAN BEINGS IF INHALED IN SUFFICIENT QUANTITIES.

Can't find the Right Firmness?

Can't find the Right Feel?

Can't find the right firmness for those super thick 8" cushions?

We can help you solve the problem with a "Sandwich" construction. A core of two foams to get that right comfortable feel.

Get the right initial feel and Get the right deep down support.



Quality Foam Sold Here!

As a Fabricator of over 60
Foams, we know that foam is
not just foam. It is our goal
to carry Good & Constant
Foams at each Quality Range.

© 2007 ACTIVE FOAM

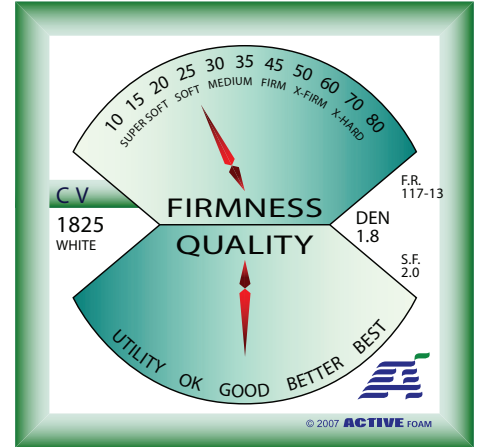
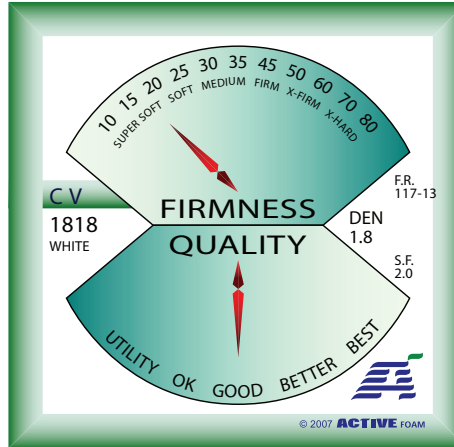

FOUR LEVEL PRICING

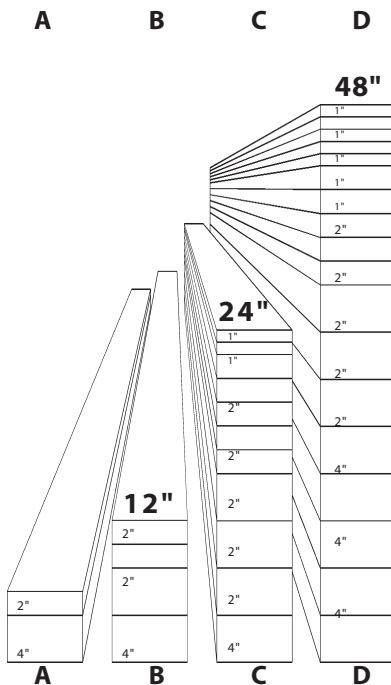

Pricing on foam is based on the quantity purchased. The first level, "A PRICING", is on purchases less than 12" of total height. To reach the second pricing level, "B PRICING", a total of 12" must be purchased of a single foam type. An example: 2 sheets of #2235 4"x24"x82" & 2 sheets of #2235 2"x30"x82" would equal 12"s. If the order was doubled, the total height would be 24" reaching the third level, "C PRICING". Level four, "D PRICING" is the top pricing level that can be reached on a total height of 48".

For Thickness not listed here, Pricing is proportionally based and Volume Discounts apply. Upcharge may apply to thicknesses less than one inch.

CV1818 VERY SOFT

24" x 82"

SIZES	A	B	C	D
1"	28.20	25.90	24.80	23.60
1½"	42.30	38.90	37.20	35.40
2"	56.40	51.80	49.60	47.20
2½"	70.50	64.80	62.00	59.00
3"	84.60	77.70	74.40	70.80
3½"	98.70	90.70	86.80	82.60
4"	112.80	103.60	99.20	94.40
4½"	126.90	116.60	111.60	106.20
5"	141.00	129.50	124.00	118.00
5½"	155.10	142.50	136.40	129.80
6"	169.20	155.40	148.80	141.60
7"	197.40	181.30	173.60	165.20

48" x 82"

1"	56.40	51.80	49.60	47.20
1½"	84.60	77.70	74.40	70.80
2"	112.80	103.60	99.20	94.40
2½"	141.00	129.50	124.00	118.00
3"	169.20	155.40	148.80	141.60
3½"	197.40	181.30	173.60	165.20
4"	225.60	207.20	198.40	188.80
4½"	253.80	233.10	223.20	212.40
5"	282.00	259.00	248.00	236.00
5½"	310.20	284.90	272.80	259.60
6"	338.40	310.80	297.60	283.20
7"	394.80	362.60	347.20	330.40

CV1825 SOFT

24" x 82"

SIZES	A	B	C	D
1"	28.20	25.90	24.80	23.60
1½"	42.30	38.90	37.20	35.40
2"	56.40	51.80	49.60	47.20
2½"	70.50	64.80	62.00	59.00
3"	84.60	77.70	74.40	70.80
3½"	98.70	90.70	86.80	82.60
4"	112.80	103.60	99.20	94.40
4½"	126.90	116.60	111.60	106.20
5"	141.00	129.50	124.00	118.00
5½"	155.10	142.50	136.40	129.80
6"	169.20	155.40	148.80	141.60
7"	197.40	181.30	173.60	165.20

30" x 82"

1"	35.30	32.40	31.00	29.50
1½"	52.90	48.60	46.50	44.30
2"	70.50	64.80	62.00	59.00
2½"	88.20	81.00	77.50	73.80
3"	105.80	97.20	93.00	88.50
3½"	123.40	113.40	108.50	103.30
4"	141.00	129.50	124.00	118.00
4½"	158.70	145.70	139.50	132.80
5"	176.30	161.90	155.00	147.50
5½"	193.90	178.10	170.50	162.30
6"	211.50	194.30	186.00	177.00
7"	246.80	226.70	217.00	206.50

48" x 82"

1"	56.40	51.80	49.60	47.20
1½"	84.60	77.70	74.40	70.80
2"	112.80	103.60	99.20	94.40
2½"	141.00	129.50	124.00	118.00
3"	169.20	155.40	148.80	141.60
3½"	197.40	181.30	173.60	165.20
4"	225.60	207.20	198.40	188.80
4½"	253.80	233.10	223.20	212.40
5"	282.00	259.00	248.00	236.00
5½"	310.20	284.90	272.80	259.60
6"	338.40	310.80	297.60	283.20
7"	394.80	362.60	347.20	330.40

60" x 82"

1"	70.50	64.80	62.00	59.00
1½"	105.80	97.20	93.00	88.50
2"	141.00	129.50	124.00	118.00
2½"	176.30	161.90	155.00	147.50
3"	211.50	194.30	186.00	177.00
3½"	246.80	226.70	217.00	206.50
4"	282.00	259.00	248.00	236.00
4½"	317.30	291.40	279.00	265.50
5"	352.50	323.80	310.00	295.00
5½"	387.80	356.20	341.00	324.50
6"	423.00	388.50	372.00	354.00
7"	493.50	453.30	434.00	413.00

WARNING

URETHANE FOAM IS FLAMMABLE!

DO NOT EXPOSE URETHANE FOAMS TO OPEN FLAMES OR ANY OTHER DIRECT OR INDIRECT HIGH TEMPERATURE IGNITION SOURCES SUCH AS BURNING OPERATIONS, WELDING, BURNING CIGARETTES, SPACE HEATERS OR NAKED LIGHTS.

ONCE IGNITED, URETHANE FOAMS WILL BURN RAPIDLY, RELEASING GREAT HEAT AND CONSUMING OXYGEN AT A HIGH RATE. IN AN ENCLOSED SPACE THE RESULTING DEFICIENCY OF OXYGEN WILL PRESENT A DANGER OF SUFFOCATION TO THE OCCUPANTS. HAZARDOUS GASES RELEASED BY THE BURNING FOAM CAN LEAD TO INCAPACITATION OR BE FATAL TO HUMAN BEINGS IF INHALED IN SUFFICIENT QUANTITIES.

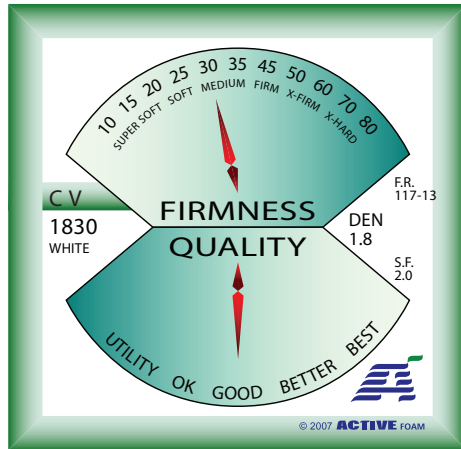

CV1830 MED-SOFT

24" x 82"

SIZES	A	B	C	D
1"	28.20	25.90	24.80	23.60
1½"	42.30	38.90	37.20	35.40
2"	56.40	51.80	49.60	47.20
2½"	70.50	64.80	62.00	59.00
3"	84.60	77.70	74.40	70.80
3½"	98.70	90.70	86.80	82.60
4"	112.80	103.60	99.20	94.40
4½"	126.90	116.60	111.60	106.20
5"	141.00	129.50	124.00	118.00
5½"	155.10	142.50	136.40	129.80
6"	169.20	155.40	148.80	141.60
7"	197.40	181.30	173.60	165.20

30" x 82"

1"	35.30	32.40	31.00	29.50
1½"	52.90	48.60	46.50	44.30
2"	70.50	64.80	62.00	59.00
2½"	88.20	81.00	77.50	73.80
3"	105.80	97.20	93.00	88.50
3½"	123.40	113.40	108.50	103.30
4"	141.00	129.50	124.00	118.00
4½"	158.70	145.70	139.50	132.80
5"	176.30	161.90	155.00	147.50
5½"	193.90	178.10	170.50	162.30
6"	211.50	194.30	186.00	177.00
7"	246.80	226.70	217.00	206.50

60" x 82"

1"	70.50	64.80	62.00	59.00
1½"	105.80	97.20	93.00	88.50
2"	141.00	129.50	124.00	118.00
2½"	176.30	161.90	155.00	147.50
3"	211.50	194.30	186.00	177.00
3½"	246.80	226.70	217.00	206.50
4"	282.00	259.00	248.00	236.00
4½"	317.30	291.40	279.00	265.50
5"	352.50	323.80	310.00	295.00
5½"	387.80	356.20	341.00	324.50
6"	423.00	388.50	372.00	354.00
7"	493.50	453.30	434.00	413.00

We are willing to help you!

Need help with a foam for your application?

Give us a call, we are happy to assist.

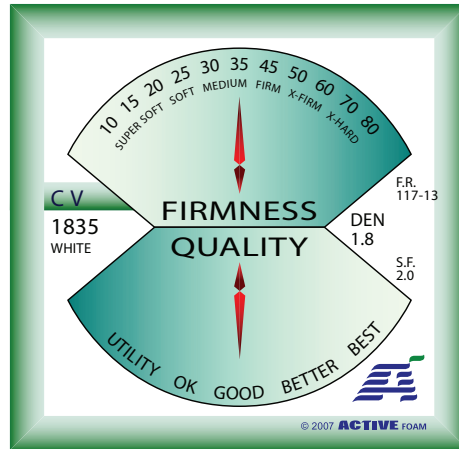

CV1835 MEDIUM

24" x 82"

SIZES	A	B	C	D
1"	28.20	25.90	24.80	23.60
1½"	42.30	38.90	37.20	35.40
2"	56.40	51.80	49.60	47.20
2½"	70.50	64.80	62.00	59.00
3"	84.60	77.70	74.40	70.80
3½"	98.70	90.70	86.80	82.60
4"	112.80	103.60	99.20	94.40
4½"	126.90	116.60	111.60	106.20
5"	141.00	129.50	124.00	118.00
5½"	155.10	142.50	136.40	129.80
6"	169.20	155.40	148.80	141.60
7"	197.40	181.30	173.60	165.20

30" x 82"

1"	35.30	32.40	31.00	29.50
1½"	52.90	48.60	46.50	44.30
2"	70.50	64.80	62.00	59.00
2½"	88.20	81.00	77.50	73.80
3"	105.80	97.20	93.00	88.50
3½"	123.40	113.40	108.50	103.30
4"	141.00	129.50	124.00	118.00
4½"	158.70	145.70	139.50	132.80
5"	176.30	161.90	155.00	147.50
5½"	193.90	178.10	170.50	162.30
6"	211.50	194.30	186.00	177.00
7"	246.80	226.70	217.00	206.50

48" x 82"

1"	56.40	51.80	49.60	47.20
1½"	84.60	77.70	74.40	70.80
2"	112.80	103.60	99.20	94.40
2½"	141.00	129.50	124.00	118.00
3"	169.20	155.40	148.80	141.60
3½"	197.40	181.30	173.60	165.20
4"	225.60	207.20	198.40	188.80
4½"	253.80	233.10	223.20	212.40
5"	282.00	259.00	248.00	236.00
5½"	310.20	284.90	272.80	259.60
6"	338.40	310.80	297.60	283.20
7"	394.80	362.60	347.20	330.40

60" x 82"

1"	70.50	64.80	62.00	59.00
1½"	105.80	97.20	93.00	88.50
2"	141.00	129.50	124.00	118.00
2½"	176.30	161.90	155.00	147.50
3"	211.50	194.30	186.00	177.00
3½"	246.80	226.70	217.00	206.50
4"	282.00	259.00	248.00	236.00
4½"	317.30	291.40	279.00	265.50
5"	352.50	323.80	310.00	295.00
5½"	387.80	356.20	341.00	324.50
6"	423.00	388.50	372.00	354.00
7"	493.50	453.30	434.00	413.00

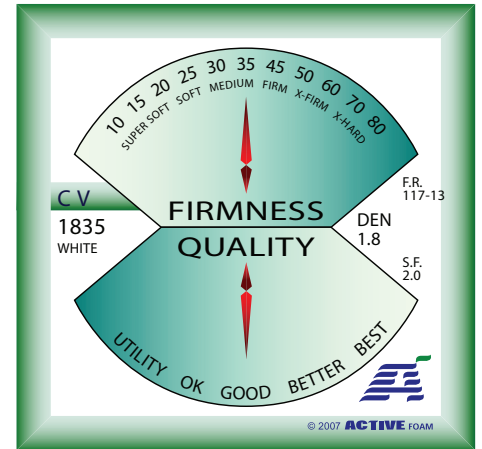

CV1835 MEDIUM

24" x 108"

SIZES	A	B	C	D
1"	37.40	34.30	32.60	30.50
1½"	56.10	51.50	48.90	45.80
2"	74.80	68.60	65.20	61.00
2½"	93.50	85.80	81.50	76.30
3"	112.20	102.90	97.80	91.50
3½"	130.90	120.10	114.10	106.80
4"	149.60	137.20	130.40	122.00
4½"	168.30	154.40	146.70	137.30
5"	187.00	171.50	163.00	152.50
5½"	205.70	188.70	179.30	167.80
6"	224.40	205.80	195.60	183.00
7"	261.80	240.10	228.20	213.50

82" x 108"

1"	127.80	117.20	111.40	104.30
1½"	191.70	175.80	167.10	156.40
2"	255.60	234.40	222.80	208.50
2½"	319.50	293.00	278.50	260.60
3"	383.40	351.60	334.20	312.70
3½"	447.30	410.20	389.90	364.80
4"	511.20	468.80	445.60	416.90
4½"	575.10	527.40	501.30	469.00
5"	639.00	586.00	557.00	521.10
5½"	702.90	644.60	612.70	573.20
6"	766.70	703.20	668.30	625.30
7"	894.50	820.40	779.70	729.50

FIRE RETARDANT FOAMS



Doing a job that needs to comply with a particular fire code?

Foams are not just Fire Retardant, they are Fire Retardant to a particular code.

We can help. We additionally stock polyester cushion-wraps that meet various fire codes.



Quality Foam Sold Here!

As a Fabricator of over 60
Foams, we know that foam is
not just foam. It is our goal
to carry Good & Consistent
Foams at each Quality Range.

© 2007 ACTIVE FOAM

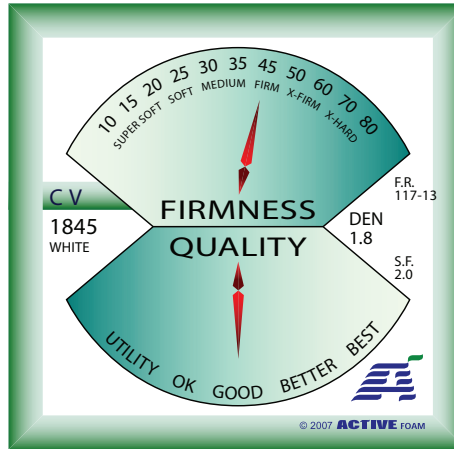

© 2007 ACTIVE FOAM

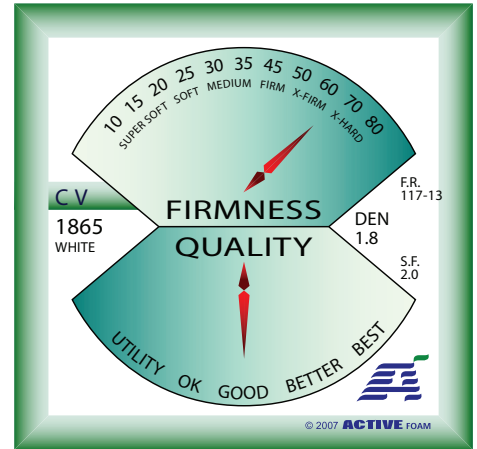

© 2007 ACTIVE FOAM

FOUR LEVEL PRICING

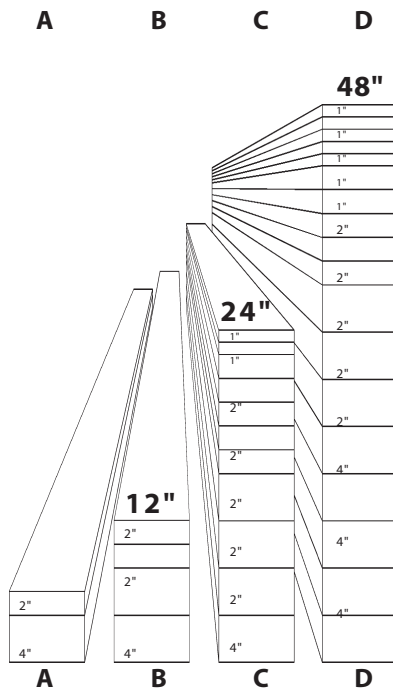

Pricing on foam is based on the quantity purchased. The first level, "A PRICING", is on purchases less than 12" of total height. To reach the second pricing level, "B PRICING", a total of 12" must be purchased of a single foam type. An example: 2 sheets of #2235 4"x24"x82" & 2 sheets of #2235 2"x30"x82" would equal 12"s. If the order was doubled, the total height would be 24" reaching the third level, "C PRICING". Level four, "D PRICING" is the top pricing level that can be reached on a total height of 48".

For Thickness not listed here, Pricing is proportionally based and Volume Discounts apply. Upcharge may apply to thicknesses less than one inch.

CV1845 FIRM

20" x 82"

SIZES	A	B	C	D
1"	23.50	21.60	20.70	19.70
1½"	35.30	32.40	31.00	29.50
2"	47.00	43.20	41.40	39.40
2½"	58.80	54.00	51.70	49.20
3"	70.50	64.80	62.00	59.00
3½"	82.30	75.60	72.40	68.90
4"	94.00	86.40	82.70	78.70
4½"	105.80	97.20	93.00	88.50
5"	117.50	108.00	103.40	98.40
5½"	129.30	118.80	113.70	108.20
6"	141.00	129.50	124.00	118.00
7"	164.50	151.10	144.70	137.70

24" x 82"

SIZES	A	B	C	D
1"	28.20	25.90	24.80	23.60
1½"	42.30	38.90	37.20	35.40
2"	56.40	51.80	49.60	47.20
2½"	70.50	64.80	62.00	59.00
3"	84.60	77.70	74.40	70.80
3½"	98.70	90.70	86.80	82.60
4"	112.80	103.60	99.20	94.40
4½"	126.90	116.60	111.60	106.20
5"	141.00	129.50	124.00	118.00
5½"	155.10	142.50	136.40	129.80
6"	169.20	155.40	148.80	141.60
7"	197.40	181.30	173.60	165.20

30" x 82"

SIZES	A	B	C	D
1"	35.30	32.40	31.00	29.50
1½"	52.90	48.60	46.50	44.30
2"	70.50	64.80	62.00	59.00
2½"	88.20	81.00	77.50	73.80
3"	105.80	97.20	93.00	88.50
3½"	123.40	113.40	108.50	103.30
4"	141.00	129.50	124.00	118.00
4½"	158.70	145.70	139.50	132.80
5"	176.30	161.90	155.00	147.50
5½"	193.90	178.10	170.50	162.30
6"	211.50	194.30	186.00	177.00
7"	246.80	226.70	217.00	206.50

60" x 82"

SIZES	A	B	C	D
1"	70.50	64.80	62.00	59.00
1½"	105.80	97.20	93.00	88.50
2"	141.00	129.50	124.00	118.00
2½"	176.30	161.90	155.00	147.50
3"	211.50	194.30	186.00	177.00
3½"	246.80	226.70	217.00	206.50
4"	282.00	259.00	248.00	236.00
4½"	317.30	291.40	279.00	265.50
5"	352.50	323.80	310.00	295.00
5½"	387.80	356.20	341.00	324.50
6"	423.00	388.50	372.00	354.00
7"	493.50	453.30	434.00	413.00

CV1865 X-FIRM

24" x 82"

SIZES	A	B	C	D
1"	34.90	32.90	30.30	28.30
1½"	52.40	49.40	45.50	42.50
2"	69.80	65.80	60.60	56.60
2½"	87.30	82.30	75.80	70.80
3"	104.70	98.70	90.90	84.90
3½"	122.20	115.20	106.10	99.10
4"	139.60	131.60	121.20	113.20
4½"	157.10	148.10	136.40	127.40
5"	174.50	164.50	151.50	141.50
5½"	192.00	181.00	166.70	155.70
6"	209.40	197.40	181.80	169.80
7"	244.30	230.30	212.10	198.10

48" x 82"

SIZES	A	B	C	D
1"	69.80	65.80	60.60	56.60
1½"	104.70	98.70	90.90	84.90
2"	139.60	131.60	121.20	113.20
2½"	174.50	164.50	151.50	141.50
3"	209.40	197.40	181.80	169.80
3½"	244.30	230.30	212.10	198.10
4"	279.20	263.20	242.40	226.40
4½"	314.10	296.10	272.70	254.70
5"	349.00	329.00	303.00	283.00
5½"	383.90	361.90	333.30	311.30
6"	418.80	394.80	363.60	339.60
7"	488.60	460.60	424.20	396.20

Can't find the Right Firmness?

Can't find the Right Feel?



We provide Foam Samples
for no charge.

Ask for your Sampler to shipped
with your next order

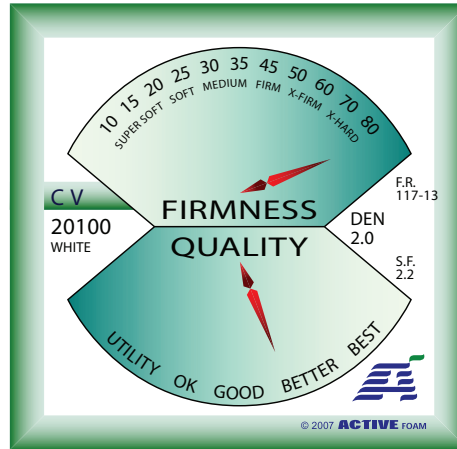
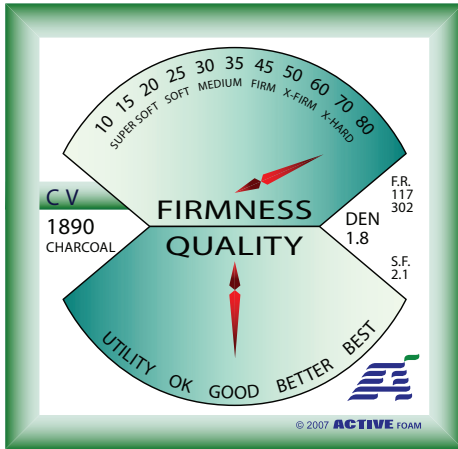

FOAMS THAT FEEL

GOOD

AND

YOU CAN FEEL GOOD

ABOUT

- Made without ozone depleters
- Made without PBDE flame retardants
- Made without mercury, lead and other heavy metals
- Made without formaldehyde
- Made without phthalates regulated by the Consumer Product Safety Commission
- Low VOC (Volatile Organic Compounds) emissions for indoor air quality
- Tested and approved for durability and performance.

More Information is on Pages 12-13.

For the most complete resource on CertiPUR-US® go to <http://certipur.us>

CV1890 X-HARD

24" x 82"

SIZES	A	B	C	D
1"	44.80	40.60	37.00	35.70
1½"	67.20	60.90	55.50	53.60
2"	89.60	81.20	74.00	71.40
2½"	112.00	101.50	92.50	89.30
3"	134.40	121.80	111.00	107.10
3½"	156.80	142.10	129.50	125.00
4"	179.20	162.40	148.00	142.80
4½"	201.60	182.70	166.50	160.70
5"	224.00	203.00	185.00	178.50
5½"	246.40	223.30	203.50	196.40
6"	268.80	243.60	222.00	214.20
7"	313.60	284.20	259.00	249.90

48" x 82"

1"	89.60	81.20	74.00	71.40
1½"	134.40	121.80	111.00	107.10
2"	179.20	162.40	148.00	142.80
2½"	224.00	203.00	185.00	178.50
3"	268.80	243.60	222.00	214.20
3½"	313.60	284.20	259.00	249.90
4"	358.40	324.80	296.00	285.60
4½"	403.20	365.40	333.00	321.30
5"	448.00	406.00	370.00	357.00
5½"	492.80	446.60	407.00	392.70
6"	537.60	487.20	444.00	428.40
7"	627.20	568.40	518.00	499.80

CV20100 S-HARD

24" x 82"

SIZES	A	B	C	D
1"	46.90	44.80	42.90	41.00
1½"	70.40	67.20	64.40	61.50
2"	93.80	89.60	85.80	82.00
2½"	117.30	112.00	107.30	102.50
3"	140.70	134.40	128.70	123.00
3½"	164.20	156.80	150.20	143.50
4"	187.60	179.20	171.60	164.00
4½"	211.10	201.60	193.10	184.50
5"	234.50	224.00	214.50	205.00
5½"	258.00	246.40	236.00	225.50
6"	281.40	268.80	257.40	246.00
7"	328.30	313.60	300.30	287.00

The Illinois Furniture Fire Safety Act

Do you know what Occupancies are governed by the "Act"?

- (1) Jails, prisons and convalescent homes;
- (2) Hospitals, mental health facilities, and similar health care facilities;
- (3) Nursing care and convalescent homes;
- (4) Child day care centers;
- (5) Public auditoriums and stadiums; and
- (6) Public assembly areas of hotels and motels containing more than 10 articles of seating furniture.

Need help complying with the "ACT"?

We can help. Don't turn down a job because it looks like a compliance headache, give us a call.

The State Fire Marshall's Office publishes a "Rules & Regulations" that explains in detail the definitions of the above terms. This document is a must read and we will provide it for free upon request. Please contact us if you have any questions on complying with the Act.

Can't find the Right Firmness?

Can't find the Right Feel?



Can't find the right firmness for those super thick 8" cushions?

We can help you solve the problem with a "Sandwich" construction. A core of two foams to get that right comfortable feel.

Get the right initial feel and Get the right deep down support.

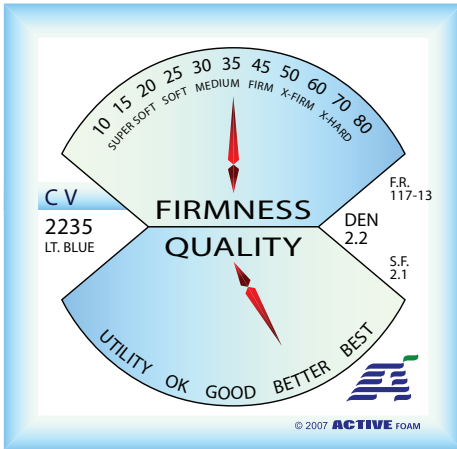

CV2235 MEDIUM

24" x 82"

SIZES	A	B	C	D
1"	37.20	34.90	32.80	31.10
1½"	55.80	52.40	49.20	46.70
2"	74.40	69.80	65.60	62.20
2½"	93.00	87.30	82.00	77.80
3"	111.60	104.70	98.40	93.30
3½"	130.20	122.20	114.80	108.90
4"	148.80	139.60	131.20	124.40
4½"	167.40	157.10	147.60	140.00
5"	186.00	174.50	164.00	155.50
5½"	204.60	192.00	180.40	171.10
6"	223.20	209.40	196.80	186.60
7"	260.40	244.30	229.60	217.70

30" x 82"

1"	46.50	43.70	41.00	38.90
1½"	69.80	65.50	61.50	58.40
2"	93.00	87.30	82.00	77.80
2½"	116.30	109.10	102.50	97.20
3"	139.50	130.90	123.00	116.70
3½"	162.80	152.70	143.50	136.10
4"	186.00	174.50	164.00	155.50
4½"	209.30	196.40	184.50	175.00
5"	232.50	218.20	205.00	194.40
5½"	255.80	240.00	225.50	213.90
6"	279.00	261.80	246.00	233.30
7"	325.50	305.40	287.00	272.20

48" x 82"

1"	74.40	69.80	65.60	62.20
1½"	111.60	104.70	98.40	93.30
2"	148.80	139.60	131.20	124.40
2½"	186.00	174.50	164.00	155.50
3"	223.20	209.40	196.80	186.60
3½"	260.40	244.30	229.60	217.70
4"	297.60	279.20	262.40	248.80
4½"	334.80	314.10	295.20	279.90
5"	372.00	349.00	328.00	311.00
5½"	409.20	383.90	360.80	342.10
6"	446.40	418.80	393.60	373.20
7"	520.80	488.60	459.20	435.40

60" x 82"

1"	93.00	87.30	82.00	77.80
1½"	139.50	130.90	123.00	116.70
2"	186.00	174.50	164.00	155.50
2½"	232.50	218.20	205.00	194.40
3"	279.00	261.80	246.00	233.30
3½"	325.50	305.40	287.00	272.20
4"	372.00	349.00	328.00	311.00
4½"	418.50	392.70	369.00	349.90
5"	465.00	436.30	410.00	388.80
5½"	511.50	479.90	451.00	427.70
6"	558.00	523.50	492.00	466.50
7"	651.00	610.80	574.00	544.30

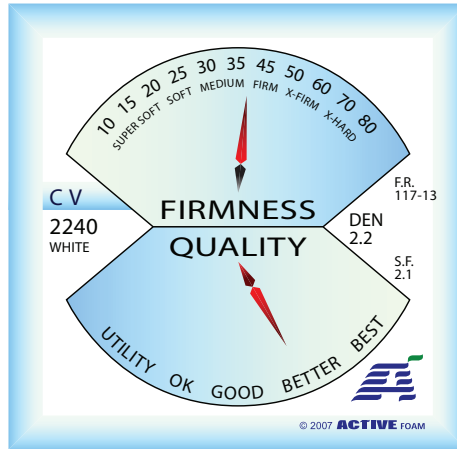

CV2240 MED-FIRM

24" x 96"

SIZES	A	B	C	D
1"	42.50	39.90	38.30	37.20
1½"	63.80	59.90	57.50	55.80
2"	85.00	79.80	76.60	74.40
2½"	106.30	99.80	95.80	93.00
3"	127.50	119.70	114.90	111.60
3½"	148.80	139.70	134.10	130.20
4"	170.00	159.60	153.20	148.80
4½"	191.30	179.60	172.40	167.40
5"	212.50	199.50	191.50	186.00
5½"	233.80	219.50	210.70	204.60
6"	255.00	239.40	229.80	223.20
7"	297.50	279.30	268.10	260.40

30" x 96"

1"	53.20	49.90	47.90	46.50
1½"	79.70	74.90	71.90	69.80
2"	106.30	99.80	95.80	93.00
2½"	132.90	124.70	119.70	116.30
3"	159.40	149.70	143.70	139.50
3½"	186.00	174.60	167.60	162.80
4"	212.50	199.50	191.50	186.00
4½"	239.10	224.50	215.50	209.30
5"	265.70	249.40	239.40	232.50
5½"	292.20	274.40	263.40	255.80
6"	318.80	299.30	287.30	279.00
7"	371.90	349.20	335.20	325.50

82" x 96"

1"	145.30	136.40	130.90	127.10
1½"	217.90	204.50	196.30	190.70
2"	290.50	272.70	261.80	254.20
2½"	363.10	340.90	327.20	317.80
3"	435.70	409.00	392.60	381.30
3½"	508.30	477.20	458.10	444.90
4"	580.90	545.30	523.50	508.40
4½"	653.50	613.50	588.90	572.00
5"	726.10	681.70	654.30	635.50
5½"	798.70	749.80	719.80	699.10
6"	871.30	818.00	785.20	762.60
7"	1016.50	954.30	916.10	889.70

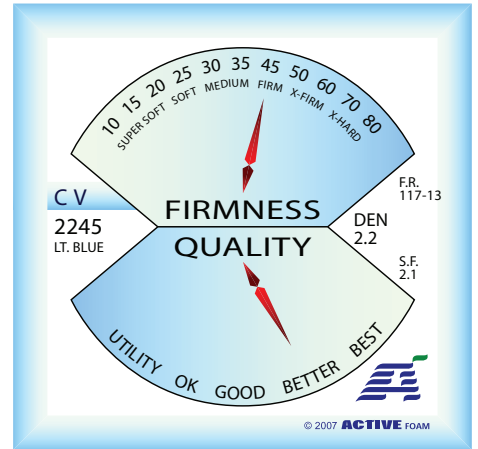

CV2245 FIRM

20" x 82"

SIZES	A	B	C	D
1"	31.00	29.10	27.40	26.00
1½"	46.50	43.70	41.00	38.90
2"	62.00	58.20	54.70	51.90
2½"	77.50	72.80	68.40	64.80
3"	93.00	87.30	82.00	77.80
3½"	108.50	101.80	95.70	90.80
4"	124.00	116.40	109.40	103.70
4½"	139.50	130.90	123.00	116.70
5"	155.00	145.50	136.70	129.60
5½"	170.50	160.00	150.40	142.60
6"	186.00	174.50	164.00	155.50
7"	217.00	203.60	191.40	181.50

24" x 82"

1"	37.20	34.90	32.80	31.10
1½"	55.80	52.40	49.20	46.70
2"	74.40	69.80	65.60	62.20
2½"	93.00	87.30	82.00	77.80
3"	111.60	104.70	98.40	93.30
3½"	130.20	122.20	114.80	108.90
4"	148.80	139.60	131.20	124.40
4½"	167.40	157.10	147.60	140.00
5"	186.00	174.50	164.00	155.50
5½"	204.60	192.00	180.40	171.10
6"	223.20	209.40	196.80	186.60
7"	260.40	244.30	229.60	217.70

30" x 82"

1"	46.50	43.70	41.00	38.90
1½"	69.80	65.50	61.50	58.40
2"	93.00	87.30	82.00	77.80
2½"	116.30	109.10	102.50	97.20
3"	139.50	130.90	123.00	116.70
3½"	162.80	152.70	143.50	136.10
4"	186.00	174.50	164.00	155.50
4½"	209.30	196.40	184.50	175.00
5"	232.50	218.20	205.00	194.40
5½"	255.80	240.00	225.50	213.90
6"	279.00	261.80	246.00	233.30
7"	325.50	305.40	287.00	272.20

60" x 82"

1"	93.00	87.30	82.00	77.80
1½"	139.50	130.90	123.00	116.70
2"	186.00	174.50	164.00	155.50
2½"	232.50	218.20	205.00	194.40
3"	279.00	261.80	246.00	233.30
3½"	325.50	305.40	287.00	272.20
4"	372.00	349.00	328.00	311.00
4½"	418.50	392.70	369.00	349.90
5"	465.00	436.30	410.00	388.80
5½"	511.50	479.90	451.00	427.70
6"	558.00	523.50	492.00	466.50
7"	651.00	610.80	574.00	544.30



"Blue Poly" 2200^s Feel Great!

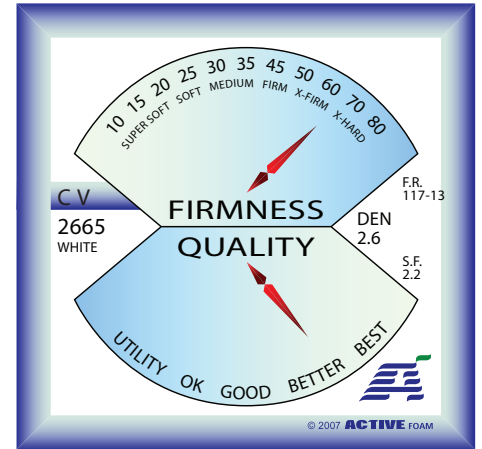
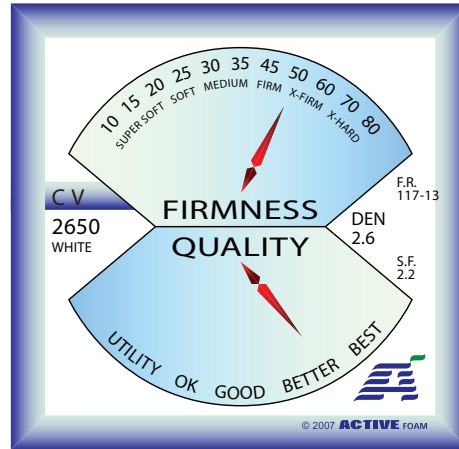
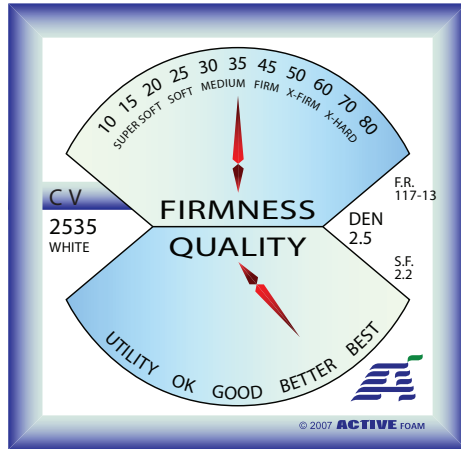

CV2535 MEDIUM

24" x 80"

SIZES	A	B	C	D
1"	42.70	40.40	38.10	36.00
1½"	64.10	60.60	57.20	54.00
2"	85.40	80.80	76.20	72.00
2½"	106.80	101.00	95.30	90.00
3"	128.10	121.20	114.30	108.00
3½"	149.50	141.40	133.40	126.00
4"	170.80	161.60	152.40	144.00
4½"	192.20	181.80	171.50	162.00
5"	213.50	202.00	190.50	180.00
5½"	234.90	222.20	209.60	198.00
6"	256.20	242.40	228.60	216.00
7"	298.90	282.80	266.70	252.00

30" x 80"

SIZES	A	B	C	D
1"	53.40	50.50	47.70	45.00
1½"	80.10	75.80	71.50	67.50
2"	106.80	101.00	95.30	90.00
2½"	133.50	126.30	119.10	112.50
3"	160.20	151.50	142.90	135.00
3½"	186.90	176.80	166.70	157.50
4"	213.50	202.00	190.50	180.00
4½"	240.20	227.30	214.40	202.50
5"	266.90	252.50	238.20	225.00
5½"	293.60	277.80	262.00	247.50
6"	320.30	303.00	285.80	270.00
7"	373.70	353.50	333.40	315.00

48" x 80"

SIZES	A	B	C	D
1"	85.40	80.80	76.20	72.00
1½"	128.10	121.20	114.30	108.00
2"	170.80	161.60	152.40	144.00
2½"	213.50	202.00	190.50	180.00
3"	256.20	242.40	228.60	216.00
3½"	298.90	282.80	266.70	252.00
4"	341.60	323.20	304.80	288.00
4½"	384.30	363.60	342.90	324.00
5"	427.00	404.00	381.00	360.00
5½"	469.70	444.40	419.10	396.00
6"	512.40	484.80	457.20	432.00
7"	597.80	565.60	533.40	504.00

60" x 80"

SIZES	A	B	C	D
1"	106.80	101.00	95.30	90.00
1½"	160.20	151.50	142.90	135.00
2"	213.50	202.00	190.50	180.00
2½"	266.90	252.50	238.20	225.00
3"	320.30	303.00	285.80	270.00
3½"	373.70	353.50	333.40	315.00
4"	427.00	404.00	381.00	360.00
4½"	480.40	454.50	428.70	405.00
5"	533.80	505.00	476.30	450.00
5½"	587.20	555.50	523.90	495.00
6"	640.50	606.00	571.50	540.00
7"	747.30	707.00	666.80	630.00

CV2650 FIRM

20" x 82"

SIZES	A	B	C	D
1"	36.60	34.70	33.00	31.00
1½"	54.90	52.00	49.40	46.50
2"	73.20	69.40	65.90	62.00
2½"	91.50	86.70	82.30	77.50
3"	109.80	104.00	98.80	93.00
3½"	128.10	121.40	115.30	108.50
4"	146.40	138.70	131.70	124.00
4½"	164.70	156.00	148.20	139.50
5"	183.00	173.40	164.60	155.00
5½"	201.30	190.70	181.10	170.50
6"	219.50	208.00	197.50	186.00
7"	256.10	242.70	230.50	217.00

24" x 82"

SIZES	A	B	C	D
1"	43.90	41.60	39.50	37.20
1½"	65.90	62.40	59.30	55.80
2"	87.80	83.20	79.00	74.40
2½"	109.80	104.00	98.80	93.00
3"	131.70	124.80	118.50	111.60
3½"	153.70	145.60	138.30	130.20
4"	175.60	166.40	158.00	148.80
4½"	197.60	187.20	177.80	167.40
5"	219.50	208.00	197.50	186.00
5½"	241.50	228.80	217.30	204.60
6"	263.40	249.60	237.00	223.20
7"	307.30	291.20	276.50	260.40

30" x 82"

SIZES	A	B	C	D
1"	54.90	52.00	49.40	46.50
1½"	82.40	78.00	74.10	69.80
2"	109.80	104.00	98.80	93.00
2½"	137.20	130.00	123.50	116.30
3"	164.70	156.00	148.20	139.50
3½"	192.10	182.00	172.90	162.80
4"	219.50	208.00	197.50	186.00
4½"	247.00	234.00	222.20	209.30
5"	274.40	260.00	246.90	232.50
5½"	301.90	286.00	271.60	255.80
6"	329.30	312.00	296.30	279.00
7"	384.20	364.00	345.70	325.50

60" x 82"

SIZES	A	B	C	D
1"	109.80	104.00	98.80	93.00
1½"	164.70	156.00	148.20	139.50
2"	219.50	208.00	197.50	186.00
2½"	274.40	260.00	246.90	232.50
3"	329.30	312.00	296.30	279.00
3½"	384.20	364.00	345.70	325.50
4"	439.00	416.00	395.00	372.00
4½"	493.90	468.00	444.40	418.50
5"	548.80	520.00	493.80	465.00
5½"	603.70	572.00	543.20	511.50
6"	658.50	624.00	592.50	558.00
7"	768.30	728.00	691.30	651.00

CV2665 X-FIRM

20" x 82"

SIZES	A	B	C	D
1"	36.60	34.70	33.00	31.00
1½"	54.90	52.00	49.40	46.50
2"	73.20	69.40	65.90	62.00
2½"	91.50	86.70	82.30	77.50
3"	109.80	104.00	98.80	93.00
3½"	128.10	121.40	115.30	108.50
4"	146.40	138.70	131.70	124.00
4½"	164.70	156.00	148.20	139.50
5"	183.00	173.40	164.60	155.00
5½"	201.30	190.70	181.10	170.50
6"	219.50	208.00	197.50	186.00
7"	256.10	242.70	230.50	217.00

24" x 82"

SIZES	A	B	C	D
1"	43.90	41.60	39.50	37.20
1½"	65.90	62.40	59.30	55.80
2"	87.80	83.20	79.00	74.40
2½"	109.80	104.00	98.80	93.00
3"	131.70	124.80	118.50	111.60
3½"	153.70	145.60	138.30	130.20
4"	175.60	166.40	158.00	148.80
4½"	197.60	187.20	177.80	167.40
5"	219.50	208.00	197.50	186.00
5½"	241.50	228.80	217.30	204.60
6"	263.40	249.60	237.00	223.20
7"	307.30	291.20	276.50	260.40

60" x 82"

SIZES	A	B	C	D
1"	109.80	104.00	98.80	93.00
1½"	164.70	156.00	148.20	139.50
2"	219.50	208.00	197.50	186.00
2½"	274.40	260.00	246.90	232.50
3"	329.30	312.00	296.30	279.00
3½"	384.20	364.00	345.70	325.50
4"	439.00	416.00	395.00	372.00
4½"	493.90	468.00	444.40	418.50
5"	548.80	520.00	493.80	465.00
5½"	603.70	572.00	543.20	511.50
6"	658.50	624.00	592.50	558.00
7"	768.30	728.00	691.30	651.00



www.PFA.org

Their website can be a great resource for current issues & literature on flexible foams.



Quality Foam Sold Here!

As a fabricator of over 60 foams, we know that foam is not just foam. It is our goal to carry good and consistent foams at each quality range.

© 2007 ACTIVE FOAM

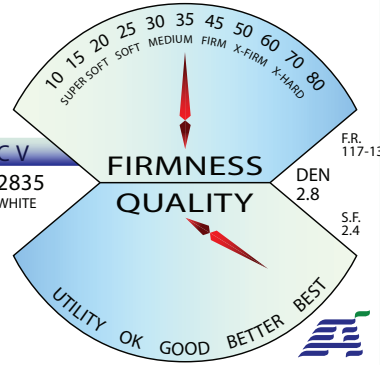

© 2007 ACTIVE FOAM

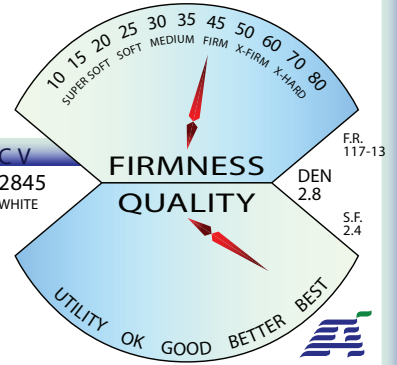

© 2007 ACTIVE FOAM

FOUR LEVEL PRICING

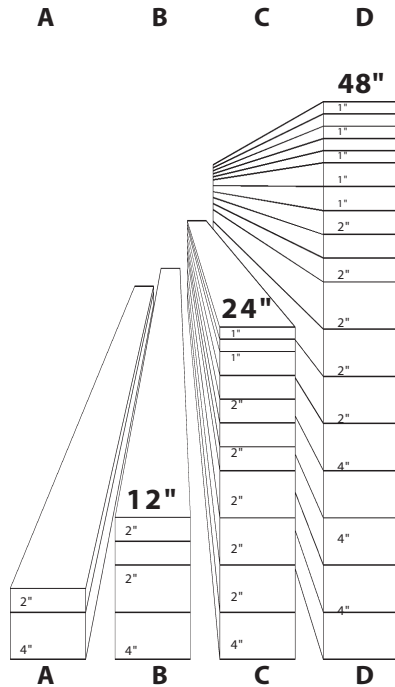

Pricing on foam is based on the quantity purchased. The first level, "A PRICING", is on purchases less than 12" of total height. To reach the second pricing level, "B PRICING", a total of 12" must be purchased of a single foam type. An example: 2 sheets of #2235 4"x24"x82" & 2 sheets of #2235 2"x30"x82" would equal 12"s. If the order was doubled, the total height would be 24" reaching the third level, "C PRICING". Level four, "D PRICING" is the top pricing level that can be reached on a total height of 48".

For Thickness not listed here, Pricing is proportionally based and Volume Discounts apply. Upcharge may apply to thicknesses less than one inch.

CV2835 MEDIUM

24" x 82"

SIZES	A	B	C	D
1"	49.40	47.10	44.80	42.70
1½"	74.10	70.70	67.20	64.10
2"	98.80	94.20	89.60	85.40
2½"	123.50	117.80	112.00	106.80
3"	148.20	141.30	134.40	128.10
3½"	172.90	164.90	156.80	149.50
4"	197.60	188.40	179.20	170.80
4½"	222.30	212.00	201.60	192.20
5"	247.00	235.50	224.00	213.50
5½"	271.70	259.10	246.40	234.90
6"	296.40	282.60	268.80	256.20
7"	345.80	329.70	313.60	298.90

30" x 82"

SIZES	A	B	C	D
1"	61.80	58.90	56.00	53.40
1½"	92.70	88.40	84.00	80.10
2"	123.50	117.80	112.00	106.80
2½"	154.40	147.20	140.00	133.50
3"	185.30	176.70	168.00	160.20
3½"	216.20	206.10	196.00	186.90
4"	247.00	235.50	224.00	213.50
4½"	277.90	265.00	252.00	240.20
5"	308.80	294.40	280.00	266.90
5½"	339.70	323.90	308.00	293.60
6"	370.50	353.30	336.00	320.30
7"	432.30	412.20	392.00	373.70

48" x 82"

SIZES	A	B	C	D
1"	98.80	94.20	89.60	85.40
1½"	148.20	141.30	134.40	128.10
2"	197.60	188.40	179.20	170.80
2½"	247.00	235.50	224.00	213.50
3"	296.40	282.60	268.80	256.20
3½"	345.80	329.70	313.60	298.90
4"	395.20	376.80	358.40	341.60
4½"	444.60	423.90	403.20	384.30
5"	494.00	471.00	448.00	427.00
5½"	543.40	518.10	492.80	469.70
6"	592.80	565.20	537.60	512.40
7"	691.60	659.40	627.20	597.80

60" x 82"

SIZES	A	B	C	D
1"	123.50	117.80	112.00	106.80
1½"	185.30	176.70	168.00	160.20
2"	247.00	235.50	224.00	213.50
2½"	308.80	294.40	280.00	266.90
3"	370.50	353.30	336.00	320.30
3½"	432.30	412.20	392.00	373.70
4"	494.00	471.00	448.00	427.00
4½"	555.80	529.90	504.00	480.40
5"	617.50	588.80	560.00	533.80
5½"	679.30	647.70	616.00	587.20
6"	741.00	706.50	672.00	640.50
7"	864.50	824.30	784.00	747.30

CV2845 FIRM

24" x 82"

SIZES	A	B	C	D
1"	49.40	47.10	44.80	42.70
1½"	74.10	70.70	67.20	64.10
2"	98.80	94.20	89.60	85.40
2½"	123.50	117.80	112.00	106.80
3"	148.20	141.30	134.40	128.10
3½"	172.90	164.90	156.80	149.50
4"	197.60	188.40	179.20	170.80
4½"	222.30	212.00	201.60	192.20
5"	247.00	235.50	224.00	213.50
5½"	271.70	259.10	246.40	234.90
6"	296.40	282.60	268.80	256.20
7"	345.80	329.70	313.60	298.90

48" x 82"

SIZES	A	B	C	D
1"	98.80	94.20	89.60	85.40
1½"	148.20	141.30	134.40	128.10
2"	197.60	188.40	179.20	170.80
2½"	247.00	235.50	224.00	213.50
3"	296.40	282.60	268.80	256.20
3½"	345.80	329.70	313.60	298.90
4"	395.20	376.80	358.40	341.60
4½"	444.60	423.90	403.20	384.30
5"	494.00	471.00	448.00	427.00
5½"	543.40	518.10	492.80	469.70
6"	592.80	565.20	537.60	512.40
7"	691.60	659.40	627.20	597.80

60" x 82"

SIZES	A	B	C	D
1"	123.50	117.80	112.00	106.80
1½"	185.30	176.70	168.00	160.20
2"	247.00	235.50	224.00	213.50
2½"	308.80	294.40	280.00	266.90
3"	370.50	353.30	336.00	320.30
3½"	432.30	412.20	392.00	373.70
4"	494.00	471.00	448.00	427.00
4½"	555.80	529.90	504.00	480.40
5"	617.50	588.80	560.00	533.80
5½"	679.30	647.70	616.00	587.20
6"	741.00	706.50	672.00	640.50
7"	864.50	824.30	784.00	747.30

"High Comfort"
2800° Feel
so Luxurious
& Lively!

The Highest
Quality
Conventional
Foams
Made!



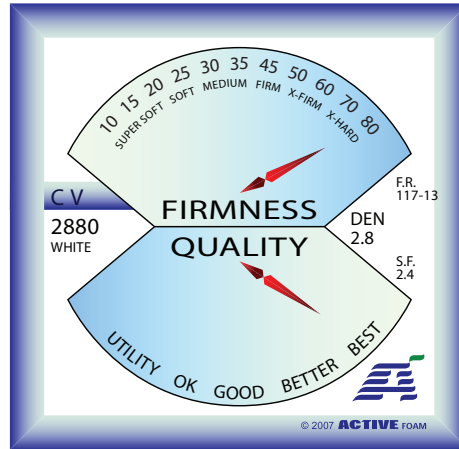
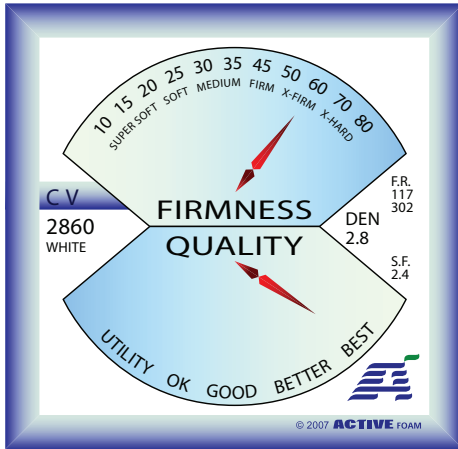

**FOAMS THAT FEEL
GOOD
AND
YOU CAN FEEL GOOD
ABOUT**

- Made without ozone depleters
- Made without PBDE flame retardants
- Made without mercury, lead and other heavy metals
- Made without formaldehyde
- Made without phthalates regulated by the Consumer Product Safety Commission
- Low VOC (Volatile Organic Compounds) emissions for indoor air quality
- Tested and approved for durability and performance.

The CertiPUR-US® program is administered by a not-for-profit organization and is the most rigorous and comprehensive certification for polyurethane foam.

WHY IS CERTIFICATION IMPORTANT?

Responsible foam suppliers here in the U.S. were concerned that there was no way for consumers to know what was inside foam products used in bedding and upholstered furniture.

Today, U.S. and foreign foam suppliers may participate in the program, as long as they meet the rigorous certification guidelines.

More Information is on Pages 12-13.

For the most complete resource on CertiPUR-US® go to <http://certipur.us>

CV2860 X-FIRM

24" x 82"

SIZES	A	B	C	D
1"	49.40	47.10	44.80	42.70
1½"	74.10	70.70	67.20	64.10
2"	98.80	94.20	89.60	85.40
2½"	123.50	117.80	112.00	106.80
3"	148.20	141.30	134.40	128.10
3½"	172.90	164.90	156.80	149.50
4"	197.60	188.40	179.20	170.80
4½"	222.30	212.00	201.60	192.20
5"	247.00	235.50	224.00	213.50
5½"	271.70	259.10	246.40	234.90
6"	296.40	282.60	268.80	256.20
7"	345.80	329.70	313.60	298.90

48" x 82"

1"	98.80	94.20	89.60	85.40
1½"	148.20	141.30	134.40	128.10
2"	197.60	188.40	179.20	170.80
2½"	247.00	235.50	224.00	213.50
3"	296.40	282.60	268.80	256.20
3½"	345.80	329.70	313.60	298.90
4"	395.20	376.80	358.40	341.60
4½"	444.60	423.90	403.20	384.30
5"	494.00	471.00	448.00	427.00
5½"	543.40	518.10	492.80	469.70
6"	592.80	565.20	537.60	512.40
7"	691.60	659.40	627.20	597.80

60" x 82"

1"	123.50	117.80	112.00	106.80
1½"	185.30	176.70	168.00	160.20
2"	247.00	235.50	224.00	213.50
2½"	308.80	294.40	280.00	266.90
3"	370.50	353.30	336.00	320.30
3½"	432.30	412.20	392.00	373.70
4"	494.00	471.00	448.00	427.00
4½"	555.80	529.90	504.00	480.40
5"	617.50	588.80	560.00	533.80
5½"	679.30	647.70	616.00	587.20
6"	741.00	706.50	672.00	640.50
7"	864.50	824.30	784.00	747.30

CV2880 X-HARD

20" x 82"

SIZES	A	B	C	D
1"	44.20	42.30	40.50	38.50
1½"	66.30	63.40	60.80	57.80
2"	88.40	84.50	81.00	77.00
2½"	110.50	105.70	101.30	96.30
3"	132.50	126.80	121.50	115.50
3½"	154.60	147.90	141.80	134.80
4"	176.70	169.00	162.00	154.00
4½"	198.80	190.20	182.30	173.30
5"	220.90	211.30	202.50	192.50
5½"	243.00	232.40	222.80	211.80
6"	265.00	253.50	243.00	231.00
7"	309.20	295.80	283.50	269.50

24" x 82"

1"	53.00	50.70	48.60	46.20
1½"	79.50	76.10	72.90	69.30
2"	106.00	101.40	97.20	92.40
2½"	132.50	126.80	121.50	115.50
3"	159.00	152.10	145.80	138.60
3½"	185.50	177.50	170.10	161.70
4"	212.00	202.80	194.40	184.80
4½"	238.50	228.20	218.70	207.90
5"	265.00	253.50	243.00	231.00
5½"	291.50	278.90	267.30	254.10
6"	318.00	304.20	291.60	277.20
7"	371.00	354.90	340.20	323.40

60" x 82"

1"	132.50	126.80	121.50	115.50
1½"	198.80	190.20	182.30	173.30
2"	265.00	253.50	243.00	231.00
2½"	331.30	316.90	303.80	288.80
3"	397.50	380.30	364.50	346.50
3½"	463.80	443.70	425.30	404.30
4"	530.00	507.00	486.00	462.00
4½"	596.30	570.40	546.80	519.80
5"	662.50	633.80	607.50	577.50
5½"	728.80	697.20	668.30	635.30
6"	795.00	760.50	729.00	693.00
7"	927.50	887.30	850.50	808.50

**HIGH COMFORT
FOAMS**

High Comfort Foams are foams made with "Conventional Polyol" that achieve high sag-factors and high rebound. High Comfort Foams have a relaxed & supple cell structure giving the utmost in seating comfort.

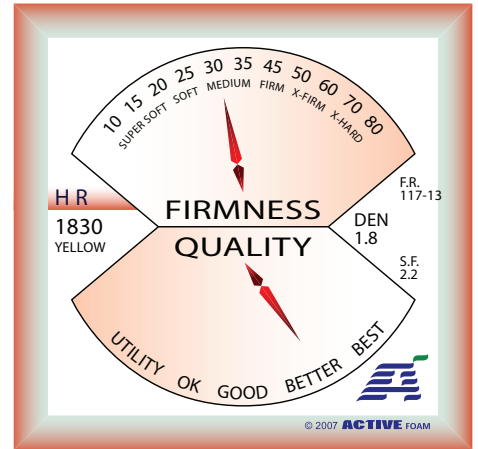
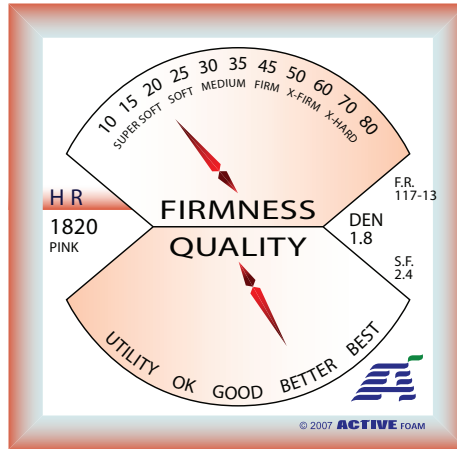
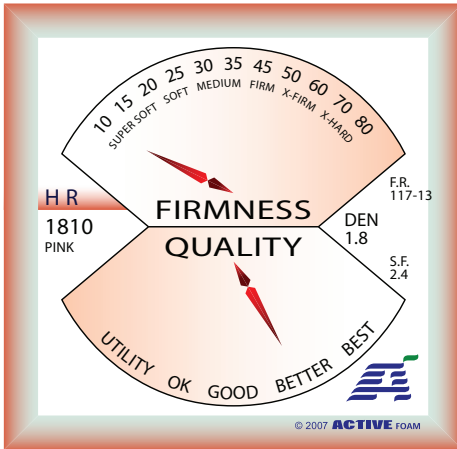

HR1810 S-SOFT

24" x 82"

SIZES	A	B	C	D
1"	37.80	35.70	34.30	33.00
1½"	56.70	53.60	51.50	49.50
2"	75.60	71.40	68.60	66.00
2½"	94.50	89.30	85.80	82.50
3"	113.40	107.10	102.90	99.00
3½"	132.30	125.00	120.10	115.50
4"	151.20	142.80	137.20	132.00
4½"	170.10	160.70	154.40	148.50
5"	189.00	178.50	171.50	165.00
5½"	207.90	196.40	188.70	181.50
6"	226.80	214.20	205.80	198.00
7"	264.60	249.90	240.10	231.00

60" x 82"

1"	94.50	89.30	85.80	82.50
1½"	141.80	133.90	128.70	123.80
2"	189.00	178.50	171.50	165.00
2½"	236.30	223.20	214.40	206.30
3"	283.50	267.80	257.30	247.50
3½"	330.80	312.40	300.20	288.80
4"	378.00	357.00	343.00	330.00
4½"	425.30	401.70	385.90	371.30
5"	472.50	446.30	428.80	412.50
5½"	519.80	490.90	471.70	453.80
6"	567.00	535.50	514.50	495.00
7"	661.50	624.80	600.30	577.50

HR1820 SOFT

24" x 82"

SIZES	A	B	C	D
1"	37.80	35.70	34.30	33.00
1½"	56.70	53.60	51.50	49.50
2"	75.60	71.40	68.60	66.00
2½"	94.50	89.30	85.80	82.50
3"	113.40	107.10	102.90	99.00
3½"	132.30	125.00	120.10	115.50
4"	151.20	142.80	137.20	132.00
4½"	170.10	160.70	154.40	148.50
5"	189.00	178.50	171.50	165.00
5½"	207.90	196.40	188.70	181.50
6"	226.80	214.20	205.80	198.00
7"	264.60	249.90	240.10	231.00

48" x 82"

1"	75.60	71.40	68.60	66.00
1½"	113.40	107.10	102.90	99.00
2"	151.20	142.80	137.20	132.00
2½"	189.00	178.50	171.50	165.00
3"	226.80	214.20	205.80	198.00
3½"	264.60	249.90	240.10	231.00
4"	302.40	285.60	274.40	264.00
4½"	340.20	321.30	308.70	297.00
5"	378.00	357.00	343.00	330.00
5½"	415.80	392.70	377.30	363.00
6"	453.60	428.40	411.60	396.00
7"	529.20	499.80	480.20	462.00

60" x 82"

1"	94.50	89.30	85.80	82.50
1½"	141.80	133.90	128.70	123.80
2"	189.00	178.50	171.50	165.00
2½"	236.30	223.20	214.40	206.30
3"	283.50	267.80	257.30	247.50
3½"	330.80	312.40	300.20	288.80
4"	378.00	357.00	343.00	330.00
4½"	425.30	401.70	385.90	371.30
5"	472.50	446.30	428.80	412.50
5½"	519.80	490.90	471.70	453.80
6"	567.00	535.50	514.50	495.00
7"	661.50	624.80	600.30	577.50

HR1830 MED-SOFT

24" x 82"

SIZES	A	B	C	D
1"	37.80	35.70	34.30	33.00
1½"	56.70	53.60	51.50	49.50
2"	75.60	71.40	68.60	66.00
2½"	94.50	89.30	85.80	82.50
3"	113.40	107.10	102.90	99.00
3½"	132.30	125.00	120.10	115.50
4"	151.20	142.80	137.20	132.00
4½"	170.10	160.70	154.40	148.50
5"	189.00	178.50	171.50	165.00
5½"	207.90	196.40	188.70	181.50
6"	226.80	214.20	205.80	198.00
7"	264.60	249.90	240.10	231.00

48" x 82"

1"	75.60	71.40	68.60	66.00
1½"	113.40	107.10	102.90	99.00
2"	151.20	142.80	137.20	132.00
2½"	189.00	178.50	171.50	165.00
3"	226.80	214.20	205.80	198.00
3½"	264.60	249.90	240.10	231.00
4"	302.40	285.60	274.40	264.00
4½"	340.20	321.30	308.70	297.00
5"	378.00	357.00	343.00	330.00
5½"	415.80	392.70	377.30	363.00
6"	453.60	428.40	411.60	396.00
7"	529.20	499.80	480.20	462.00

60" x 82"

1"	94.50	89.30	85.80	82.50
1½"	141.80	133.90	128.70	123.80
2"	189.00	178.50	171.50	165.00
2½"	236.30	223.20	214.40	206.30
3"	283.50	267.80	257.30	247.50
3½"	330.80	312.40	300.20	288.80
4"	378.00	357.00	343.00	330.00
4½"	425.30	401.70	385.90	371.30
5"	472.50	446.30	428.80	412.50
5½"	519.80	490.90	471.70	453.80
6"	567.00	535.50	514.50	495.00
7"	661.50	624.80	600.30	577.50



High Resiliency Foams are foams made with an "HR Polyol" that achieve high sag-factors and high rebound. High Resiliency Foams have a cell structure that gets firmer faster allowing for a wide range of resistance in a foam giving you the utmost in seating comfort.



All of our "HR" foams comply with California TB 117



www.PFA.org

Their website can be a great resource for current issues & literature on flexible foams.

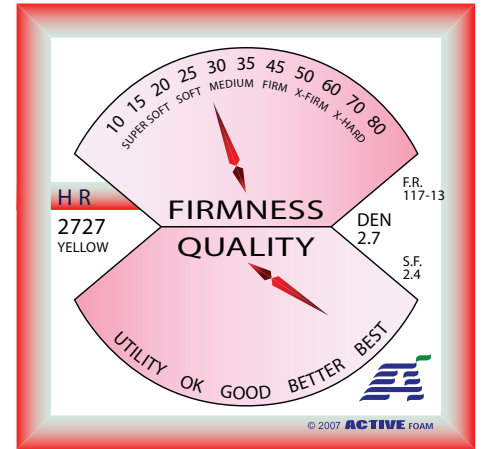
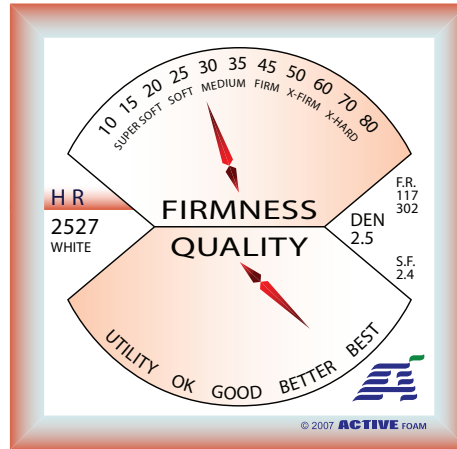
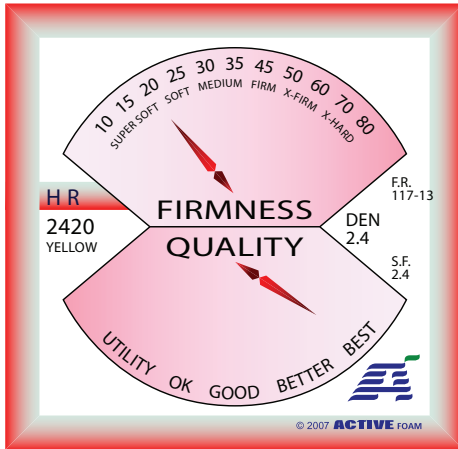

HR2420 SOFT

24" x 81"

SIZES	A	B	C	D
1"	47.70	45.00	43.90	42.30
1½"	71.60	67.50	65.90	63.50
2"	95.40	90.00	87.80	84.60
2½"	119.30	112.50	109.80	105.80
3"	143.10	135.00	131.70	126.90
3½"	167.00	157.50	153.70	148.10
4"	190.80	180.00	175.60	169.20
4½"	214.70	202.50	197.60	190.40
5"	238.50	225.00	219.50	211.50
5½"	262.40	247.50	241.50	232.70
6"	286.20	270.00	263.40	253.80
7"	333.90	315.00	307.30	296.10

30" x 81"

1"	59.70	56.30	54.90	52.90
1½"	89.50	84.40	82.40	79.40
2"	119.30	112.50	109.80	105.80
2½"	149.10	140.70	137.20	132.20
3"	178.90	168.80	164.70	158.70
3½"	208.70	196.90	192.10	185.10
4"	238.50	225.00	219.50	211.50
4½"	268.40	253.20	247.00	238.00
5"	298.20	281.30	274.40	264.40
5½"	328.00	309.40	301.90	290.90
6"	357.80	337.50	329.30	317.30
7"	417.40	393.80	384.20	370.20

48" x 81"

1"	95.40	90.00	87.80	84.60
1½"	143.10	135.00	131.70	126.90
2"	190.80	180.00	175.60	169.20
2½"	238.50	225.00	219.50	211.50
3"	286.20	270.00	263.40	253.80
3½"	333.90	315.00	307.30	296.10
4"	381.60	360.00	351.20	338.40
4½"	429.30	405.00	395.10	380.70
5"	477.00	450.00	439.00	423.00
5½"	524.70	495.00	482.90	465.30
6"	572.40	540.00	526.80	507.60
7"	667.80	630.00	614.60	592.20

HR2527 MED-SOFT

24" x 80"

SIZES	A	B	C	D
1"	47.70	45.00	43.90	42.30
1½"	71.60	67.50	65.90	63.50
2"	95.40	90.00	87.80	84.60
2½"	119.30	112.50	109.80	105.80
3"	143.10	135.00	131.70	126.90
3½"	167.00	157.50	153.70	148.10
4"	190.80	180.00	175.60	169.20
4½"	214.70	202.50	197.60	190.40
5"	238.50	225.00	219.50	211.50
5½"	262.40	247.50	241.50	232.70
6"	286.20	270.00	263.40	253.80
7"	333.90	315.00	307.30	296.10

30" x 80"

1"	59.70	56.30	54.90	52.90
1½"	89.50	84.40	82.40	79.40
2"	119.30	112.50	109.80	105.80
2½"	149.10	140.70	137.20	132.20
3"	178.90	168.80	164.70	158.70
3½"	208.70	196.90	192.10	185.10
4"	238.50	225.00	219.50	211.50
4½"	268.40	253.20	247.00	238.00
5"	298.20	281.30	274.40	264.40
5½"	328.00	309.40	301.90	290.90
6"	357.80	337.50	329.30	317.30
7"	417.40	393.80	384.20	370.20

48" x 80"

1"	95.40	90.00	87.80	84.60
1½"	143.10	135.00	131.70	126.90
2"	190.80	180.00	175.60	169.20
2½"	238.50	225.00	219.50	211.50
3"	286.20	270.00	263.40	253.80
3½"	333.90	315.00	307.30	296.10
4"	381.60	360.00	351.20	338.40
4½"	429.30	405.00	395.10	380.70
5"	477.00	450.00	439.00	423.00
5½"	524.70	495.00	482.90	465.30
6"	572.40	540.00	526.80	507.60
7"	667.80	630.00	614.60	592.20

HR2727 MED-SOFT

24" x 96"

SIZES	A	B	C	D
1"	59.70	57.40	55.30	53.00
1½"	89.60	86.10	83.00	79.50
2"	119.40	114.80	110.60	106.00
2½"	149.30	143.50	138.30	132.50
3"	179.10	172.20	165.90	159.00
3½"	209.00	200.90	193.60	185.50
4"	238.80	229.60	221.20	212.00
4½"	268.70	258.30	248.90	238.50
5"	298.50	287.00	276.50	265.00
5½"	328.40	315.70	304.20	291.50
6"	358.20	344.40	331.80	318.00
7"	417.90	401.80	387.10	371.00

30" x 96"

1"	74.70	71.80	69.20	66.30
1½"	112.00	107.70	103.70	99.40
2"	149.30	143.50	138.30	132.50
2½"	186.60	179.40	172.90	165.70
3"	223.90	215.30	207.40	198.80
3½"	261.20	251.20	242.00	231.90
4"	298.50	287.00	276.50	265.00
4½"	335.90	322.90	311.10	298.20
5"	373.20	358.80	345.70	331.30
5½"	410.50	394.70	380.20	364.40
6"	447.80	430.50	414.80	397.50
7"	522.40	502.30	483.90	463.80

48" x 96"

1"	119.40	114.80	110.60	106.00
1½"	179.10	172.20	165.90	159.00
2"	238.80	229.60	221.20	212.00
2½"	298.50	287.00	276.50	265.00
3"	358.20	344.40	331.80	318.00
3½"	417.90	401.80	387.10	371.00
4"	477.60	459.20	442.40	424.00
4½"	537.30	516.60	497.70	477.00
5"	597.00	574.00	553.00	530.00
5½"	656.70	631.40	608.30	583.00
6"	716.40	688.80	663.60	636.00
7"	835.80	803.60	774.20	742.00

60" x 96"

1"	149.30	143.50	138.30	132.50
1½"	223.90	215.30	207.40	198.80
2"	298.50	287.00	276.50	265.00
2½"	373.20	358.80	345.70	331.30
3"	447.80	430.50	414.80	397.50
3½"	522.40	502.30	483.90	463.80
4"	597.00	574.00	553.00	530.00
4½"	671.70	645.80	622.20	596.30
5"	746.30	717.50	691.30	662.50
5½"	820.90	789.30	760.40	728.80
6"	895.50	861.00	829.50	795.00
7"	1044.80	1004.50	967.80	927.50

"HR" FOAMS

High Resiliency Foams are foams made with an "HR Polyol" that achieve high sag-factors and high rebound. High Resiliency Foams have a cell structure that gets firmer faster allowing for a wide range of resistance in a foam giving you the utmost in seating comfort.





**QUALITY
FOAM
SOLD
HERE!**

AS A FABRICATOR OF OVER 60 FOAMS, WE KNOW THAT FOAM IS NOT JUST FOAM. IT IS OUR GOAL TO CARRY GOOD & CONSISTANT FOAMS AT EACH QUALITY RANGE.

© 2007 ACTIVE FOAM

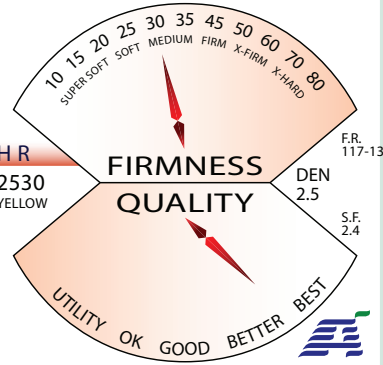

© 2007 ACTIVE FOAM

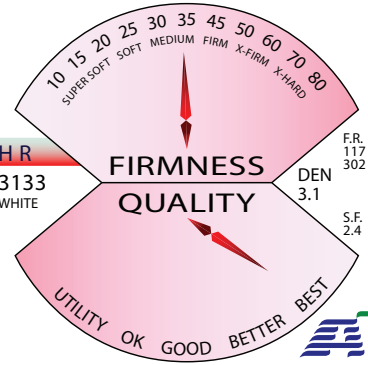

© 2007 ACTIVE FOAM

FOUR LEVEL PRICING

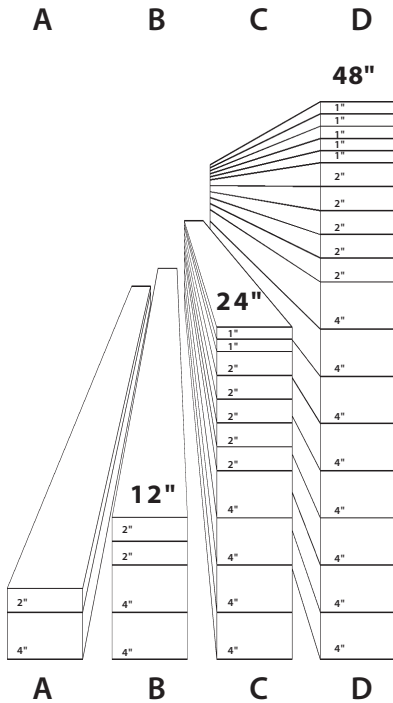

PRICING ON FOAM IS BASED ON THE QUANTITY PURCHASED. THE FIRST LEVEL, "A PRICING", IS ON PURCHASES LESS THAN 12" OF TOTAL HEIGHT. TO REACH THE SECOND PRICING LEVEL, "B PRICING, A TOTAL OF 12" MUST BE PURCHASED OF A SINGLE FOAM TYPE. AN EXAMPLE: 2 SHEETS OF #2235 4"X24"X82" & 2 SHEETS OF #2235 2"X30"X82" WOULD EQUAL 12"S. IF THE ORDER WAS DOUBLED, THE TOTAL HEIGHT WOULD BE 24" REACHING THE THIRD LEVEL, "C PRICING". LEVEL FOUR, "D PRICING" IS THE TOP PRICING LEVEL THAT CAN BE REACHED ON A TOTAL HEIGHT OF 48".

FOR THICKNESS NOT LISTED HERE, PRICING IS PROPORTIONALLY BASED AND VOLUME DISCOUNTS APPLY. UPCHARGE MAY APPLY TO THICKNESSES LESS THAN ONE INCH.

HR2530 MEDIUM

24" X 83"

SIZES	A	B	C	D
1"	47.70	45.00	43.90	42.30
1½"	71.60	67.50	65.90	63.50
2"	95.40	90.00	87.80	84.60
2½"	119.30	112.50	109.80	105.80
3"	143.10	135.00	131.70	126.90
3½"	167.00	157.50	153.70	148.10
4"	190.80	180.00	175.60	169.20
4½"	214.70	202.50	197.60	190.40
5"	238.50	225.00	219.50	211.50
5½"	262.40	247.50	241.50	232.70
6"	286.20	270.00	263.40	253.80
7"	333.90	315.00	307.30	296.10

30" X 83"

SIZES	A	B	C	D
1"	59.70	56.30	54.90	52.90
1½"	89.50	84.40	82.40	79.40
2"	119.30	112.50	109.80	105.80
2½"	149.10	140.70	137.20	132.20
3"	178.90	168.80	164.70	158.70
3½"	208.70	196.90	192.10	185.10
4"	238.50	225.00	219.50	211.50
4½"	268.40	253.20	247.00	238.00
5"	298.20	281.30	274.40	264.40
5½"	328.00	309.40	301.90	290.90
6"	357.80	337.50	329.30	317.30
7"	417.40	393.80	384.20	370.20

48" X 83"

SIZES	A	B	C	D
1"	95.40	90.00	87.80	84.60
1½"	143.10	135.00	131.70	126.90
2"	190.80	180.00	175.60	169.20
2½"	238.50	225.00	219.50	211.50
3"	286.20	270.00	263.40	253.80
3½"	333.90	315.00	307.30	296.10
4"	381.60	360.00	351.20	338.40
4½"	429.30	405.00	395.10	380.70
5"	477.00	450.00	439.00	423.00
5½"	524.70	495.00	482.90	465.30
6"	572.40	540.00	526.80	507.60
7"	667.80	630.00	614.60	592.20

60" X 83"

SIZES	A	B	C	D
1"	119.30	112.50	109.80	105.80
1½"	178.90	168.80	164.70	158.70
2"	238.50	225.00	219.50	211.50
2½"	298.20	281.30	274.40	264.40
3"	357.80	337.50	329.30	317.30
3½"	417.40	393.80	384.20	370.20
4"	477.00	450.00	439.00	423.00
4½"	536.70	506.30	493.90	475.90
5"	596.30	562.50	548.80	528.80
5½"	655.90	618.80	603.70	581.70
6"	715.50	675.00	658.50	634.50
7"	834.80	787.50	768.30	740.30

HR3133 MEDIUM

24" X 81"

SIZES	A	B	C	D
1"	55.90	53.60	51.30	49.20
1½"	83.90	80.40	77.00	73.80
2"	111.80	107.20	102.60	98.40
2½"	139.80	134.00	128.30	123.00
3"	167.70	160.80	153.90	147.60
3½"	195.70	187.60	179.60	172.20
4"	223.60	214.40	205.20	196.80
4½"	251.60	241.20	230.90	221.40
5"	279.50	268.00	256.50	246.00
5½"	307.50	294.80	282.20	270.60
6"	335.40	321.60	307.80	295.20
7"	391.30	375.20	359.10	344.40

30" X 81"

SIZES	A	B	C	D
1"	69.90	67.00	64.20	61.50
1½"	104.90	100.50	96.20	92.30
2"	139.80	134.00	128.30	123.00
2½"	174.70	167.50	160.40	153.80
3"	209.70	201.00	192.40	184.50
3½"	244.60	234.50	224.50	215.30
4"	279.50	268.00	256.50	246.00
4½"	314.50	301.50	288.60	276.80
5"	349.40	335.00	320.70	307.50
5½"	384.40	368.50	352.70	338.30
6"	419.30	402.00	384.80	369.00
7"	489.20	469.00	448.90	430.50

48" X 81"

SIZES	A	B	C	D
1"	111.80	107.20	102.60	98.40
1½"	167.70	160.80	153.90	147.60
2"	223.60	214.40	205.20	196.80
2½"	279.50	268.00	256.50	246.00
3"	335.40	321.60	307.80	295.20
3½"	391.30	375.20	359.10	344.40
4"	447.20	428.80	410.40	393.60
4½"	503.10	482.40	461.70	442.80
5"	559.00	536.00	513.00	492.00
5½"	614.90	589.60	564.30	541.20
6"	670.80	643.20	615.60	590.40
7"	782.60	750.40	718.20	688.80

60" X 81"

SIZES	A	B	C	D
1"	139.80	134.00	128.30	123.00
1½"	209.70	201.00	192.40	184.50
2"	279.50	268.00	256.50	246.00
2½"	349.40	335.00	320.70	307.50
3"	419.30	402.00	384.80	369.00
3½"	489.20	469.00	448.90	430.50
4"	559.00	536.00	513.00	492.00
4½"	628.90	603.00	577.20	553.50
5"	698.80	670.00	641.30	615.00
5½"	768.70	737.00	705.40	676.50
6"	838.50	804.00	769.50	738.00
7"	978.30	938.00	897.80	861.00

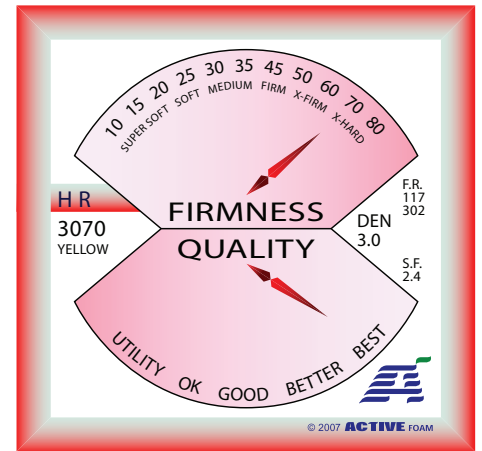
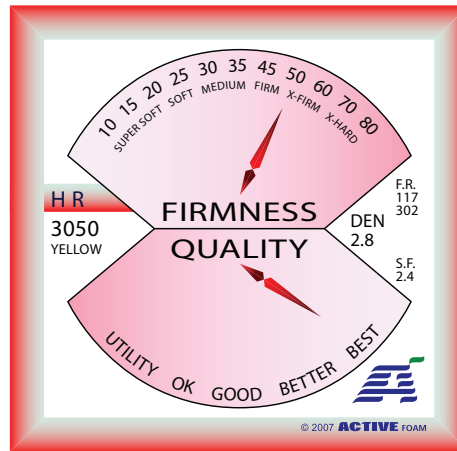
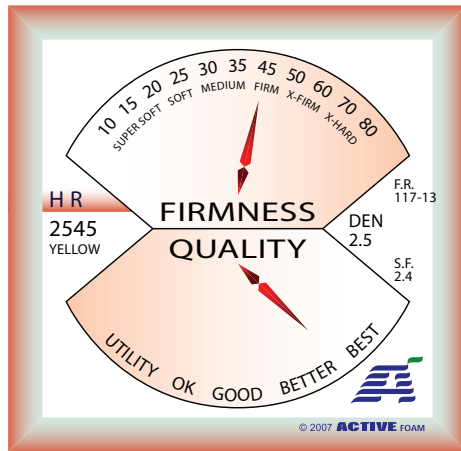

HR2545 FIRM

20" X 83"

SIZES	A	B	C	D
1"	39.80	37.50	36.60	35.30
1½"	59.70	56.30	54.90	52.90
2"	79.50	75.00	73.20	70.50
2½"	99.40	93.80	91.50	88.20
3"	119.30	112.50	109.80	105.80
3½"	139.20	131.30	128.10	123.40
4"	159.00	150.00	146.40	141.00
4½"	178.90	168.80	164.70	158.70
5"	198.80	187.50	183.00	176.30
5½"	218.70	206.30	201.30	193.90
6"	238.50	225.00	219.50	211.50
7"	278.30	262.50	256.10	246.80

24" X 83"

SIZES	A	B	C	D
1"	47.70	45.00	43.90	42.30
1½"	71.60	67.50	65.90	63.50
2"	95.40	90.00	87.80	84.60
2½"	119.30	112.50	109.80	105.80
3"	143.10	135.00	131.70	126.90
3½"	167.00	157.50	153.70	148.10
4"	190.80	180.00	175.60	169.20
4½"	214.70	202.50	197.60	190.40
5"	238.50	225.00	219.50	211.50
5½"	262.40	247.50	241.50	232.70
6"	286.20	270.00	263.40	253.80
7"	333.90	315.00	307.30	296.10

30" X 83"

SIZES	A	B	C	D
1"	59.70	56.30	54.90	52.90
1½"	89.50	84.40	82.40	79.40
2"	119.30	112.50	109.80	105.80
2½"	149.10	140.70	137.20	132.20
3"	178.90	168.80	164.70	158.70
3½"	208.70	196.90	192.10	185.10
4"	238.50	225.00	219.50	211.50
4½"	268.40	253.20	247.00	238.00
5"	298.20	281.30	274.40	264.40
5½"	328.00	309.40	301.90	290.90
6"	357.80	337.50	329.30	317.30
7"	417.40	393.80	384.20	370.20

60" X 83"

SIZES	A	B	C	D
1"	119.30	112.50	109.80	105.80
1½"	178.90	168.80	164.70	158.70
2"	238.50	225.00	219.50	211.50
2½"	298.20	281.30	274.40	264.40
3"	357.80	337.50	329.30	317.30
3½"	417.40	393.80	384.20	370.20
4"	477.00	450.00	439.00	423.00
4½"	536.70	506.30	493.90	475.90
5"	596.30	562.50	548.80	528.80
5½"	655.90	618.80	603.70	581.70
6"	715.50	675.00	658.50	634.50
7"	834.80	787.50	768.30	740.30

HR3050 FIRM

20" X 81"

SIZES	A	B	C	D
1"	51.70	49.80	47.90	46.00
1½"	77.50	74.70	71.80	68.90
2"	103.40	99.50	95.70	91.90
2½"	129.20	124.40	119.60	114.80
3"	155.00	149.30	143.50	137.80
3½"	180.90	174.20	167.50	160.80
4"	206.70	199.00	191.40	183.70
4½"	232.50	223.90	215.30	206.70
5"	258.40	248.80	239.20	229.60
5½"	284.20	273.70	263.10	252.60
6"	310.00	298.50	287.00	275.50
7"	361.70	348.30	334.90	321.50

24" X 81"

SIZES	A	B	C	D
1"	62.00	59.70	57.40	55.10
1½"	93.00	89.60	86.10	82.70
2"	124.00	119.40	114.80	110.20
2½"	155.00	149.30	143.50	137.80
3"	186.00	179.10	172.20	165.30
3½"	217.00	209.00	200.90	192.90
4"	248.00	238.80	229.60	220.40
4½"	279.00	268.70	258.30	248.00
5"	310.00	298.50	287.00	275.50
5½"	341.00	328.40	315.70	303.10
6"	372.00	358.20	344.40	330.60
7"	434.00	417.90	401.80	385.70

60" X 81"

SIZES	A	B	C	D
1"	155.00	149.30	143.50	137.80
1½"	232.50	223.90	215.30	206.70
2"	310.00	298.50	287.00	275.50
2½"	387.50	373.20	358.80	344.40
3"	465.00	447.80	430.50	413.30
3½"	542.50	522.40	502.30	482.20
4"	620.00	597.00	574.00	551.00
4½"	697.50	671.70	645.80	619.90
5"	775.00	746.30	717.50	688.80
5½"	852.50	820.90	789.30	757.70
6"	930.00	895.50	861.00	826.50
7"	1085.00	1044.80	1004.50	964.30

HR3070 X-FIRM

20" X 78"

SIZES	A	B	C	D
1"	50.00	48.10	46.20	44.30
1½"	75.00	72.20	69.30	66.40
2"	100.00	96.20	92.40	88.50
2½"	125.00	120.30	115.50	110.70
3"	150.00	144.30	138.50	132.80
3½"	175.00	168.30	161.60	154.90
4"	200.00	192.40	184.70	177.00
4½"	225.00	216.40	207.80	199.20
5"	250.00	240.50	230.90	221.30
5½"	275.00	264.50	254.00	243.40
6"	300.00	288.50	277.00	265.50
7"	350.00	336.60	323.20	309.80

24" X 78"

SIZES	A	B	C	D
1"	60.00	57.70	55.40	53.10
1½"	90.00	86.60	83.10	79.70
2"	120.00	115.40	110.80	106.20
2½"	150.00	144.30	138.50	132.80
3"	180.00	173.10	166.20	159.30
3½"	210.00	202.00	193.90	185.90
4"	240.00	230.80	221.60	212.40
4½"	270.00	259.70	249.30	239.00
5"	300.00	288.50	277.00	265.50
5½"	330.00	317.40	304.70	292.10
6"	360.00	346.20	332.40	318.60
7"	420.00	403.90	387.80	371.70

48" X 78"

SIZES	A	B	C	D
1"	120.00	115.40	110.80	106.20
1½"	180.00	173.10	166.20	159.30
2"	240.00	230.80	221.60	212.40
2½"	300.00	288.50	277.00	265.50
3"	360.00	346.20	332.40	318.60
3½"	420.00	403.90	387.80	371.70
4"	480.00	461.60	443.20	424.80
4½"	540.00	519.30	498.60	477.90
5"	600.00	577.00	554.00	531.00
5½"	660.00	634.70	609.40	584.10
6"	720.00	692.40	664.80	637.20
7"	840.00	807.80	775.60	743.40



FIRE RETARDANT FOAMS

FOAMS ARE NOT JUST "FR" OR "FIRE RETARDANT". THEY ARE "FIRE-RETARDANT" TO A SPECIFIC CODE OR A SPECIFIC STANDARD. YOUR CUSTOMERS SHOULD PROVIDE YOU WITH THE "FR" LEVEL YOU NEED TO MEET.

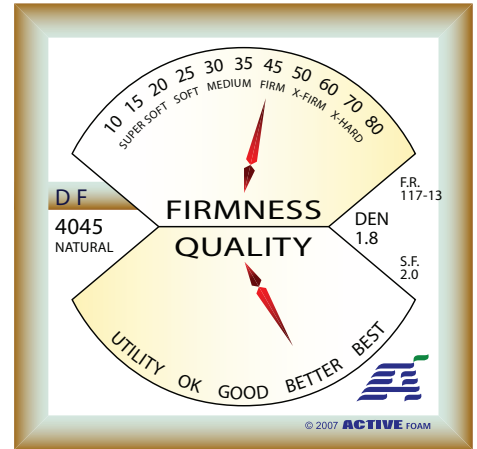
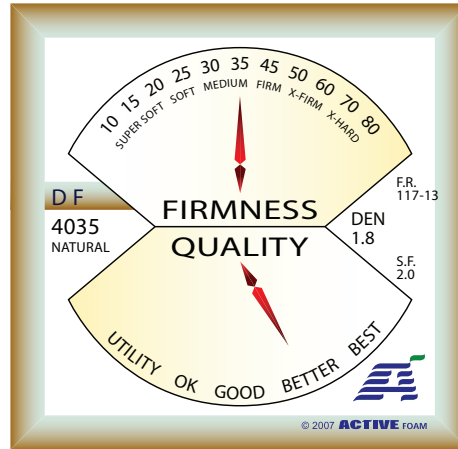
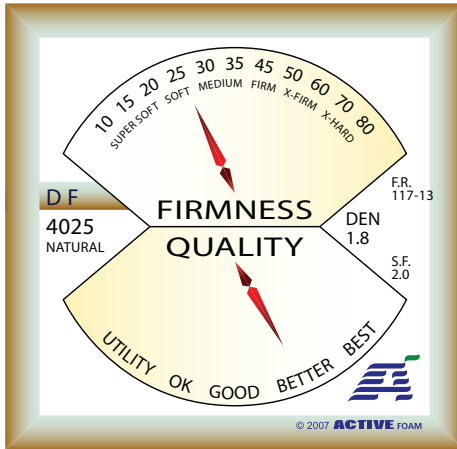

DF4025 SOFT

DF4035 MEDIUM

DF4045 FIRM

24" X 72"

24" X 72"

24" X 72"

SIZES	A	B	C	D
1"	56.00	54.00	52.00	50.00
1½"	84.00	81.00	78.00	75.00
2"	112.00	108.00	104.00	100.00
2½"	140.00	135.00	130.00	125.00
3"	168.00	162.00	156.00	150.00
3½"	196.00	189.00	182.00	175.00
4"	224.00	216.00	208.00	200.00
4½"	252.00	243.00	234.00	225.00
5"	280.00	270.00	260.00	250.00
5½"	308.00	297.00	286.00	275.00
6"	336.00	324.00	312.00	300.00
7"	392.00	378.00	364.00	350.00

SIZES	A	B	C	D
1"	56.00	54.00	52.00	50.00
1½"	84.00	81.00	78.00	75.00
2"	112.00	108.00	104.00	100.00
2½"	140.00	135.00	130.00	125.00
3"	168.00	162.00	156.00	150.00
3½"	196.00	189.00	182.00	175.00
4"	224.00	216.00	208.00	200.00
4½"	252.00	243.00	234.00	225.00
5"	280.00	270.00	260.00	250.00
5½"	308.00	297.00	286.00	275.00
6"	336.00	324.00	312.00	300.00
7"	392.00	378.00	364.00	350.00

SIZES	A	B	C	D
1"	56.00	54.00	52.00	50.00
1½"	84.00	81.00	78.00	75.00
2"	112.00	108.00	104.00	100.00
2½"	140.00	135.00	130.00	125.00
3"	168.00	162.00	156.00	150.00
3½"	196.00	189.00	182.00	175.00
4"	224.00	216.00	208.00	200.00
4½"	252.00	243.00	234.00	225.00
5"	280.00	270.00	260.00	250.00
5½"	308.00	297.00	286.00	275.00
6"	336.00	324.00	312.00	300.00
7"	392.00	378.00	364.00	350.00

48" X 72"

48" X 72"

48" X 72"

SIZES	A	B	C	D
1"	112.00	108.00	104.00	100.00
1½"	168.00	162.00	156.00	150.00
2"	224.00	216.00	208.00	200.00
2½"	280.00	270.00	260.00	250.00
3"	336.00	324.00	312.00	300.00
3½"	392.00	378.00	364.00	350.00
4"	448.00	432.00	416.00	400.00
4½"	504.00	486.00	468.00	450.00
5"	560.00	540.00	520.00	500.00
5½"	616.00	594.00	572.00	550.00
6"	672.00	648.00	624.00	600.00
7"	784.00	756.00	728.00	700.00

SIZES	A	B	C	D
1"	112.00	108.00	104.00	100.00
1½"	168.00	162.00	156.00	150.00
2"	224.00	216.00	208.00	200.00
2½"	280.00	270.00	260.00	250.00
3"	336.00	324.00	312.00	300.00
3½"	392.00	378.00	364.00	350.00
4"	448.00	432.00	416.00	400.00
4½"	504.00	486.00	468.00	450.00
5"	560.00	540.00	520.00	500.00
5½"	616.00	594.00	572.00	550.00
6"	672.00	648.00	624.00	600.00
7"	784.00	756.00	728.00	700.00

SIZES	A	B	C	D
1"	112.00	108.00	104.00	100.00
1½"	168.00	162.00	156.00	150.00
2"	224.00	216.00	208.00	200.00
2½"	280.00	270.00	260.00	250.00
3"	336.00	324.00	312.00	300.00
3½"	392.00	378.00	364.00	350.00
4"	448.00	432.00	416.00	400.00
4½"	504.00	486.00	468.00	450.00
5"	560.00	540.00	520.00	500.00
5½"	616.00	594.00	572.00	550.00
6"	672.00	648.00	624.00	600.00
7"	784.00	756.00	728.00	700.00

DRI-FAST FOAMS

Dri-Fast® Foams are highly porous allowing water to flow freely through the cells. This allows outdoor cushions to get wet and drain dry very quickly.

Uniform cells allow cushions to breathe. Additionally, Dri-Fast® foams come standard with Germicide to prevent retard mildew and fungus growth.

A great choice for cushions in:

- Boats
- Marinas
- Patios
- Pools
- Yards

**The best quality
reticulated foam
for seating available**

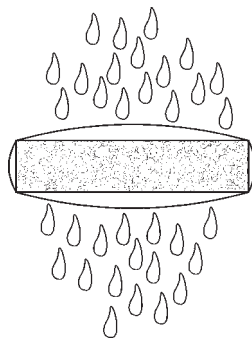

Water drainage in less than 24 hours

Dri-Fast® foams are a family of outdoor cushioning products that combine the benefits of durability, drainability and cushioning comfort. These thermally reticulated foams additionally are white pigmented to reduce UV discoloration.

Other Potential Applications:

- Boating & Water Sports Equipment
- Golf Cart Applications
- Water Control Systems
- Aqueous Filtration Systems

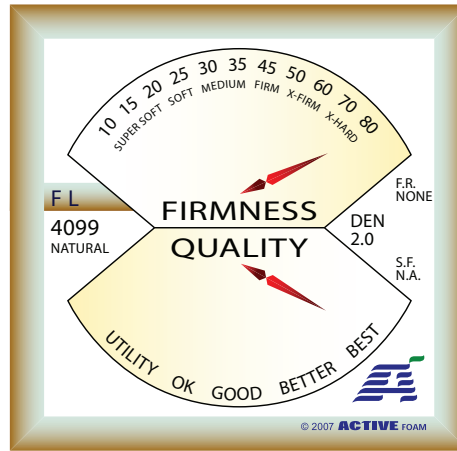
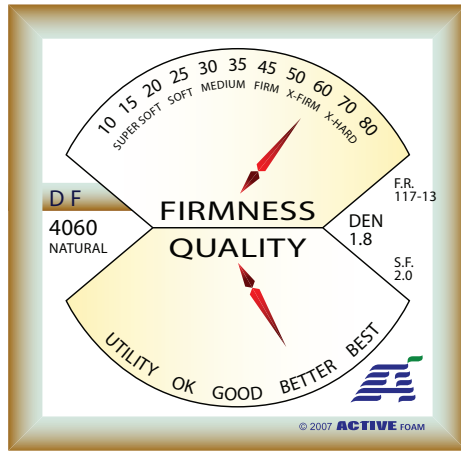

DF4060 X-FIRM

FL4099 FLOTATION

24" X 72"

24" X 96"

SIZES	A	B	C	D
1"	56.00	54.00	52.00	50.00
1½"	84.00	81.00	78.00	75.00
2"	112.00	108.00	104.00	100.00
2½"	140.00	135.00	130.00	125.00
3"	168.00	162.00	156.00	150.00
3½"	196.00	189.00	182.00	175.00
4"	224.00	216.00	208.00	200.00
4½"	252.00	243.00	234.00	225.00
5"	280.00	270.00	260.00	250.00
5½"	308.00	297.00	286.00	275.00
6"	336.00	324.00	312.00	300.00
7"	392.00	378.00	364.00	350.00

SIZES	A	B
½"	52.00	47.00
1"	94.00	84.00
1½"	141.00	126.00
2"	188.00	168.00
3"	282.00	252.00
4"	376.00	336.00

48" X 72"

48" X 96"

1"	112.00	108.00	104.00	100.00
1½"	168.00	162.00	156.00	150.00
2"	224.00	216.00	208.00	200.00
2½"	280.00	270.00	260.00	250.00
3"	336.00	324.00	312.00	300.00
3½"	392.00	378.00	364.00	350.00
4"	448.00	432.00	416.00	400.00
4½"	504.00	486.00	468.00	450.00
5"	560.00	540.00	520.00	500.00
5½"	616.00	594.00	572.00	550.00
6"	672.00	648.00	624.00	600.00
7"	784.00	756.00	728.00	700.00

½"	104.00	94.00
1"	188.00	168.00
1½"	282.00	252.00
2"	376.00	336.00
3"	564.00	504.00
4"	752.00	672.00

PLEASE NOTE:
EVEN THOUGH THIS FOAM CAN
FLOAT AND IS HIGHLY BOUYANT, IT IS
NOT COAST GUARD APPROVED AS A
FLOTATION DEVICE.

AEROSOL ADHESIVE OF CHOICE:
PREMIUM #840 OR #860 ADHESIVES.



conventional
foam cells

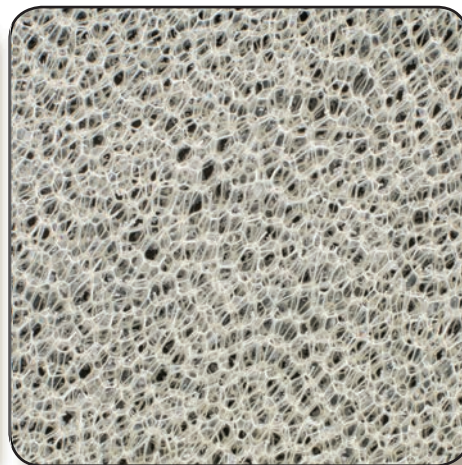

dri-fast
foam cells

**QUALITY
FOAM
SOLD
HERE!**

AS A FABRICATOR OF OVER
60 FOAMS, WE KNOW THAT
FOAM IS NOT JUST FOAM. IT IS
OUR GOAL TO CARRY GOOD &
CONSISTANT FOAMS AT EACH
QUALITY RANGE.

© 2007 ACTIVE FOAM

FOUR LEVEL PRICING

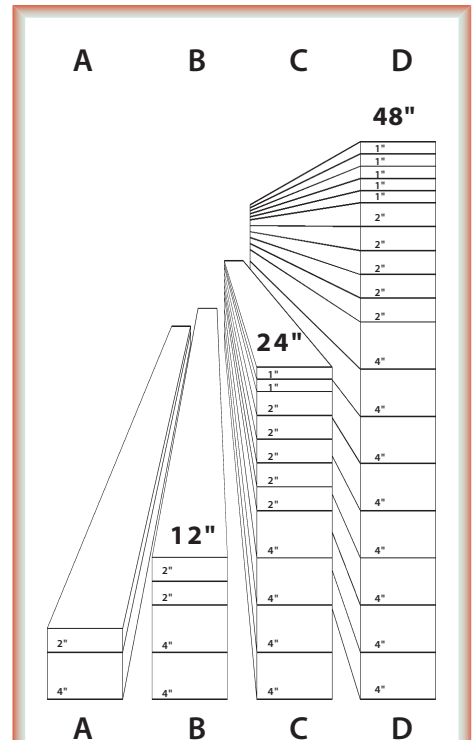

PRICING ON FOAM IS BASED ON THE
QUANTITY PURCHASED. THE FIRST
LEVEL, "A PRICING", IS ON PURCHASES
LESS THAN 12" OF TOTAL HEIGHT. TO
REACH THE SECOND PRICING LEVEL,
"B PRICING, A TOTAL OF 12" MUST
BE PURCHASED OF A SINGLE FOAM
TYPE. AN EXAMPLE: 2 SHEETS OF
#2235 4"X24"X82" & 2 SHEETS OF #2235
2"X30"X82" WOULD EQUAL 12"S. IF
THE ORDER WAS DOUBLED, THE TOTAL
HEIGHT WOULD BE 24" REACHING THE
THIRD LEVEL, "C PRICING". LEVEL FOUR,
"D PRICING" IS THE TOP PRICING LEVEL
THAT CAN BE REACHED ON A TOTAL
HEIGHT OF 48".

FOR THICKNESS NOT LISTED HERE,
PRICING IS PROPORTIONALLY
BASED AND VOLUME DISCOUNTS
APPLY. UPCHARGE MAY APPLY TO
THICKNESSES LESS THAN ONE INCH.

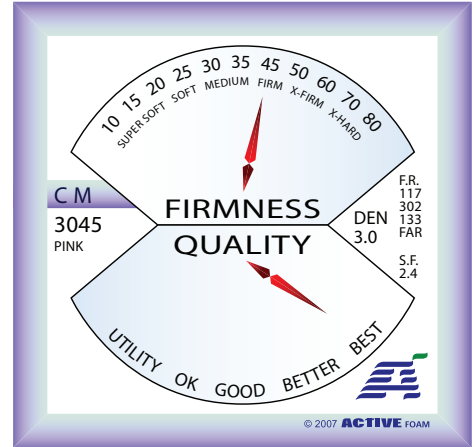
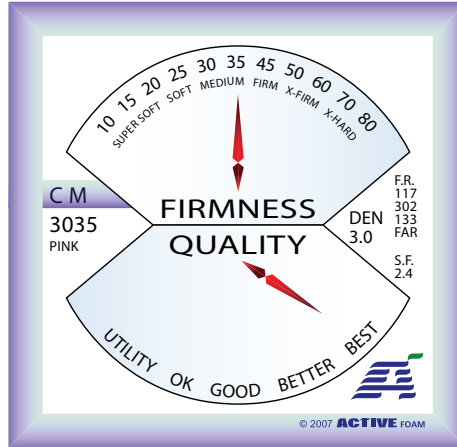

CM3025 SOFT

24" X 82"

SIZES	A	B	C	D
1"	109.20	100.80	96.60	88.20
1½"	163.80	151.20	144.90	132.30
2"	218.40	201.60	193.20	176.40
2½"	273.00	252.00	241.50	220.50
3"	327.60	302.40	289.80	264.60
3½"	382.20	352.80	338.10	308.70
4"	436.80	403.20	386.40	352.80
4½"	491.40	453.60	434.70	396.90
5"	546.00	504.00	483.00	441.00
5½"	600.60	554.40	531.30	485.10
6"	655.20	604.80	579.60	529.20
7"	764.40	705.60	676.20	617.40

48" X 82"

1"	218.40	201.60	193.20	176.40
1½"	327.60	302.40	289.80	264.60
2"	436.80	403.20	386.40	352.80
2½"	546.00	504.00	483.00	441.00
3"	655.20	604.80	579.60	529.20
3½"	764.40	705.60	676.20	617.40
4"	873.60	806.40	772.80	705.60
4½"	982.80	907.20	869.40	793.80
5"	1092.00	1008.00	966.00	882.00
5½"	1201.20	1108.80	1062.60	970.20
6"	1310.40	1209.60	1159.20	1058.40
7"	1528.80	1411.20	1352.40	1234.80

CM3035 MEDIUM

24" X 82"

SIZES	A	B	C	D
1"	109.20	100.80	96.60	88.20
1½"	163.80	151.20	144.90	132.30
2"	218.40	201.60	193.20	176.40
2½"	273.00	252.00	241.50	220.50
3"	327.60	302.40	289.80	264.60
3½"	382.20	352.80	338.10	308.70
4"	436.80	403.20	386.40	352.80
4½"	491.40	453.60	434.70	396.90
5"	546.00	504.00	483.00	441.00
5½"	600.60	554.40	531.30	485.10
6"	655.20	604.80	579.60	529.20
7"	764.40	705.60	676.20	617.40

48" X 82"

1"	218.40	201.60	193.20	176.40
1½"	327.60	302.40	289.80	264.60
2"	436.80	403.20	386.40	352.80
2½"	546.00	504.00	483.00	441.00
3"	655.20	604.80	579.60	529.20
3½"	764.40	705.60	676.20	617.40
4"	873.60	806.40	772.80	705.60
4½"	982.80	907.20	869.40	793.80
5"	1092.00	1008.00	966.00	882.00
5½"	1201.20	1108.80	1062.60	970.20
6"	1310.40	1209.60	1159.20	1058.40
7"	1528.80	1411.20	1352.40	1234.80

CM3045 FIRM

24" X 82"

SIZES	A	B	C	D
1"	109.20	100.80	96.60	88.20
1½"	163.80	151.20	144.90	132.30
2"	218.40	201.60	193.20	176.40
2½"	273.00	252.00	241.50	220.50
3"	327.60	302.40	289.80	264.60
3½"	382.20	352.80	338.10	308.70
4"	436.80	403.20	386.40	352.80
4½"	491.40	453.60	434.70	396.90
5"	546.00	504.00	483.00	441.00
5½"	600.60	554.40	531.30	485.10
6"	655.20	604.80	579.60	529.20
7"	764.40	705.60	676.20	617.40

48" X 82"

1"	218.40	201.60	193.20	176.40
1½"	327.60	302.40	289.80	264.60
2"	436.80	403.20	386.40	352.80
2½"	546.00	504.00	483.00	441.00
3"	655.20	604.80	579.60	529.20
3½"	764.40	705.60	676.20	617.40
4"	873.60	806.40	772.80	705.60
4½"	982.80	907.20	869.40	793.80
5"	1092.00	1008.00	966.00	882.00
5½"	1201.20	1108.80	1062.60	970.20
6"	1310.40	1209.60	1159.20	1058.40
7"	1528.80	1411.20	1352.40	1234.80



HAVE A FIRE CODE TO MEET?

- ASTM D-3675-1"
- ASTM E-162-79-1"
- Boston Fire Department Seating Test
- British Standard 5852:Part 2:Crib 5
- California Technical Bulletin 117-2000
- California Technical Bulletin 117-2013
- California Technical Bulletin 133
- F.A.A. Seat Cushion Requirements--
Airworthiness Standards, Section 25.853(a)
- IMO A.652(16)-Smoldering Cigarette & Butane Flame
- MVSS-302
- NFPA 260
- Port Authority of NY and NJ Padding and Cushioning
- UFAC Current Standards as of 9-81
- UL-94 (Meets 94HF1)

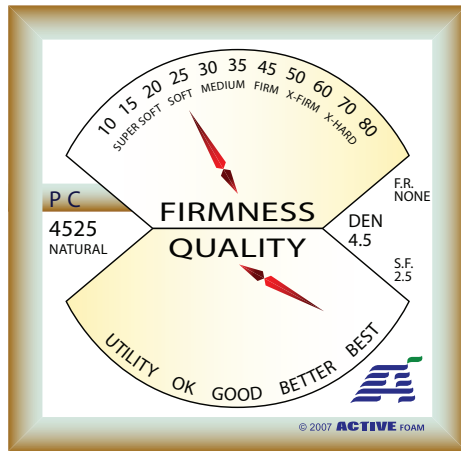

PC4525 SOFT

LATEX TOPPERS

SIZES	1"	1½"	2"
25" X 79½"	117.80	176.70	235.60
29" X 79½"	130.20	195.30	260.30
52½" X 79½"	235.60	353.40	471.20
59½" X 79½"	267.10	400.60	534.10
76" X 79½"	341.10	511.60	682.20

LATEX CORES

SIZES	4"	5"	6"
25" X 79½"	471.20	589.00	706.80
29" X 79½"	520.60	650.80	780.90
52½" X 79½"	942.40	1178.00	1413.60
59½" X 79½"	1068.10	1335.10	1602.10
76" X 79½"	1364.30	1705.30	2046.40

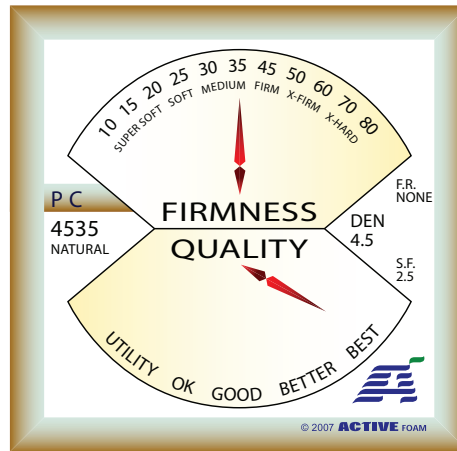

PC4535 MEDIUM

LATEX TOPPERS

SIZES	1"	1½"	2"
25" X 79½"	117.80	176.70	235.60
29" X 79½"	130.20	195.30	260.30
52½" X 79½"	235.60	353.40	471.20
59½" X 79½"	267.10	400.60	534.10
76" X 79½"	341.10	511.60	682.20

LATEX CORES

SIZES	4"	5"	6"
25" X 79½"	471.20	589.00	706.80
29" X 79½"	520.60	650.80	780.90
52½" X 79½"	942.40	1178.00	1413.60
59½" X 79½"	1068.10	1335.10	1602.10
76" X 79½"	1364.30	1705.30	2046.40

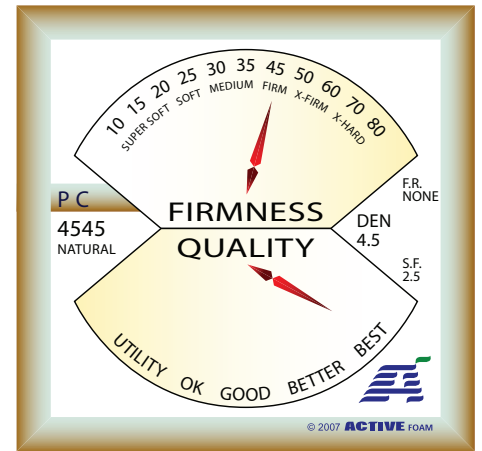

PC4545 FIRM

LATEX TOPPERS

SIZES	1"	1½"	2"
25" X 79½"	117.80	176.70	235.60
29" X 79½"	130.20	195.30	260.30
52½" X 79½"	235.60	353.40	471.20
59½" X 79½"	267.10	400.60	534.10
76" X 79½"	341.10	511.60	682.20

LATEX CORES

SIZES	4"	5"	6"
25" X 79½"	471.20	589.00	706.80
29" X 79½"	520.60	650.80	780.90
52½" X 79½"	942.40	1178.00	1413.60
59½" X 79½"	1068.10	1335.10	1602.10
76" X 79½"	1364.30	1705.30	2046.40

CUSTOM CUSHIONS

Custom Cushions with
Latex Cores or just Latex Toppers
are available.

Please inquire for pricing on your
custom sizes and shapes.

PINCORE - LATEX

Naturally supportive, latex adjust to you. Latex gives you that unmistakable comfort, contouring gently to your body while giving outstanding support.

Derived from the hevea brasiliensis, or the rubber tree, latex is the most naturally durable cushioning material available. So while it might cost a little more initially, in the long run only latex will provide the perfect balance and support for years and years.

Latex is inherently anti-microbial, mildew resistant, and dust mite resistant, making it perfect for pulmonary allergy sufferers.

How is latex different from memory foam?

Latex is made from a rubber-based product versus memory or visco-elastic foam which is derived from plastics. Latex provides "instantaneous recovery" as it contours and supports any body movement, while memory foam provides "slow recovery". With memory foam, the sleeper must wait for their body temperature to soften the foam prior to getting the true contouring support that they would experience immediately with latex.

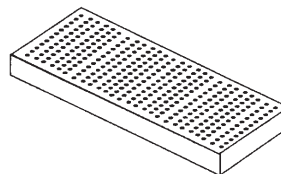

Latex is inherently anti-microbial, dust mite resistant, and mildew resistant. Mildew, staphylococcus and other bacteria simply cannot live in latex foam, making it the perfect choice for pulmonary allergy sufferers.

The Pincore configuration creates thousands of tiny air channels providing natural breathability.

Pincore Latex toppers are selling because they allow people to improve the mattress they already own at an economical price. Pincore Latex Toppers are like a sea of foam, conforming to the body's every move, something

an ordinary cushion or mattress just can't do. Latex foam relieves pressure areas that cause tossing and turning.

Latex pillows provide up to 31% more pressure relief and contouring support than memory foam pillows. XSENSOR® test results prove that our latex pillows provide contouring support for the neck and reduce high pressure areas up to 31% more than memory foam pillows. Instantaneously! No waiting for foam to respond to body heat.

XSENSOR® features 10,000 sensors that measure pressure between a body and a sleep surface. It is an indispensable tool for designing, testing and optimizing sleep surfaces for exceptional comfort and support.

Mattresses and pillows made from Talatech™ latex provide the perfect balance of comfort and support so you can enjoy deep, sound sleep night after night. Latex instantaneously conforms to the shape of your body, gently supporting and comforting you all night long, with up to 33% more pressure relief than other foam bedding. So you can awaken refreshed and rejuvenated to meet the challenges of the day—without the tossing and turning, without the pain and stiffness that disrupt a good night's sleep—with restored energy and enthusiasm.



Instant Recovery
Latex Foam



Slow Recovery
Memory Foam



QUALITY FOAM SOLD HERE!

AS A FABRICATOR OF OVER 60
FOAMS, WE KNOW THAT FOAM IS
NOT JUST FOAM. IT IS OUR GOAL
TO CARRY GOOD & CONSISTANT
FOAMS AT EACH QUALITY RANGE.

© 2007 ACTIVE FOAM

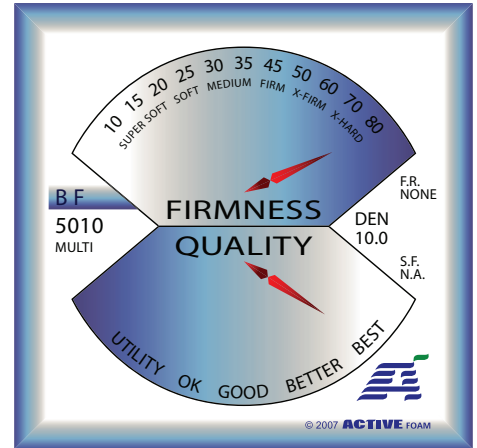
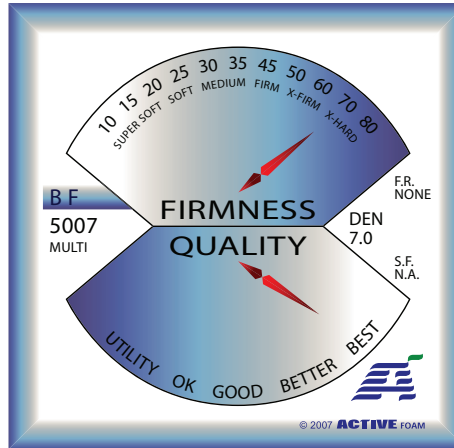

FOUR LEVEL PRICING

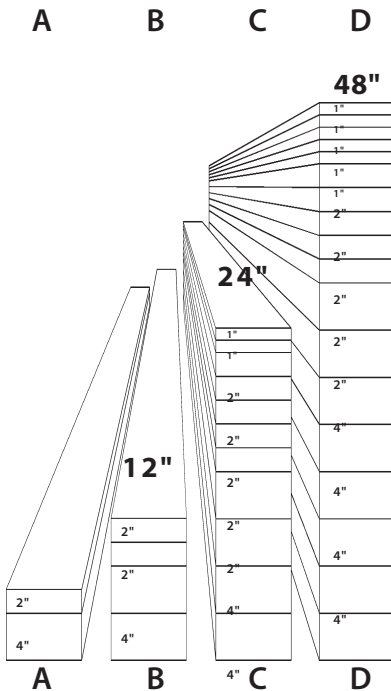

PRICING ON FOAM IS BASED ON THE
QUANTITY PURCHASED. THE FIRST
LEVEL, "A PRICING", IS ON PURCHASES
LESS THAN 12" OF TOTAL HEIGHT. TO
REACH THE SECOND PRICING LEVEL,
"B PRICING, A TOTAL OF 12" MUST
BE PURCHASED OF A SINGLE FOAM
TYPE. AN EXAMPLE: 2 SHEETS OF
#2235 4"X24"X82" & 2 SHEETS OF #2235
2"X30"X82" WOULD EQUAL 12" S. IF
THE ORDER WAS DOUBLED, THE TOTAL
HEIGHT WOULD BE 24" REACHING THE
THIRD LEVEL, "C PRICING". LEVEL FOUR,
"D PRICING" IS THE TOP PRICING LEVEL
THAT CAN BE REACHED ON A TOTAL
HEIGHT OF 48".

FOR THICKNESS NOT LISTED HERE,
PRICING IS PROPORTIONALLY
BASED AND VOLUME DISCOUNTS
APPLY. UPCHARGE MAY APPLY TO
THICKNESSES LESS THAN ONE INCH.

BF5007 7-LB BONDED

24" X 72"

SIZES	A	B	C	D
1"	41.90	40.70	38.50	36.30
1½"	62.90	61.10	57.80	54.50
2"	83.80	81.40	77.00	72.60
2½"	104.80	101.80	96.30	90.80
3"	125.70	122.10	115.50	108.90
3½"	146.70	142.50	134.80	127.10
4"	167.60	162.80	154.00	145.20
4½"	188.60	183.20	173.30	163.40
5"	209.50	203.50	192.50	181.50
5½"	230.50	223.90	211.80	199.70
6"	251.40	244.20	231.00	217.80
7"	293.30	284.90	269.50	254.10

48" X 72"

SIZES	A	B	C	D
1"	83.80	81.40	77.00	72.60
1½"	125.70	122.10	115.50	108.90
2"	167.60	162.80	154.00	145.20
2½"	209.50	203.50	192.50	181.50
3"	251.40	244.20	231.00	217.80
3½"	293.30	284.90	269.50	254.10
4"	335.20	325.60	308.00	290.40
4½"	377.10	366.30	346.50	326.70
5"	419.00	407.00	385.00	363.00
5½"	460.90	447.70	423.50	399.30
6"	502.80	488.40	462.00	435.60
7"	586.60	569.80	539.00	508.20

BF5010 10-LB BONDED

24" X 72"

SIZES	A	B	C	D
1"	55.80	52.20	50.00	47.60
1½"	83.70	78.30	75.00	71.40
2"	111.60	104.40	100.00	95.20
2½"	139.50	130.50	125.00	119.00
3"	167.40	156.60	150.00	142.80
3½"	195.30	182.70	175.00	166.60
4"	223.20	208.80	200.00	190.40
4½"	251.10	234.90	225.00	214.20
5"	279.00	261.00	250.00	238.00
5½"	306.90	287.10	275.00	261.80
6"	334.80	313.20	300.00	285.60
7"	390.60	365.40	350.00	333.20

CUTTING BONDED FOAMS

WE HIGHLY RECOMMEND IF YOU
HAVE LOTS OF RAILS & STRIPS
TO CUT, THAT YOU HAVE US CUT
IT FOR YOU. THERE ARE TWO
REASONS: 1ST IT IS ONE OF THE
MOST DIFFICULT FOAMS TO CUT.
2NDLY, ANY ERRANT CUTS ARE
UNFORGIVING AND SHOW UP
DRAMATICALLY. LET US HELP.

KNEELER FOAMS

9 & 10 LB BONDED



10LB BONDED OR 9LB BONDED ARE THE CHOICES. OPEN CELLED FOAMS NO
MATTER HOW FIRM, ARE STILL JUST AN AIRY CELL STRUCTURE. WITH THIS
APPLICATION YOU NEED A FOAM WITH A LOT OF SUBSTANCE, OR A "CLOSED
CELL FOAM". THESE BONDED GIVE YOU THE PERFORMANCE OF CLOSED CELL
FOAMS AT A FRACTION OF THE PRICE. WITH THE DENSITY OF OVER 3 TIMES
A TOP OF THE LINE URETHANE, IT WILL NOT ALLOW YOUR KNEES TO BOTTOM
OUT AND THEY ARE EXTREMELY DURABLE.

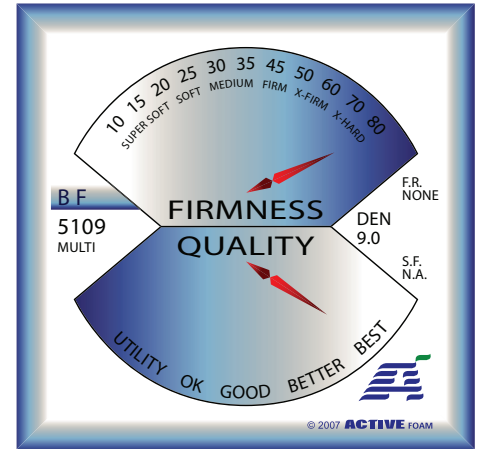
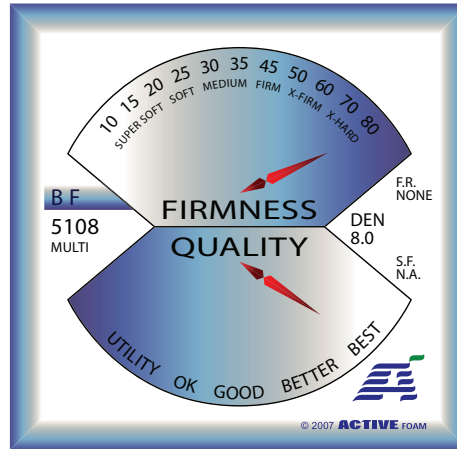
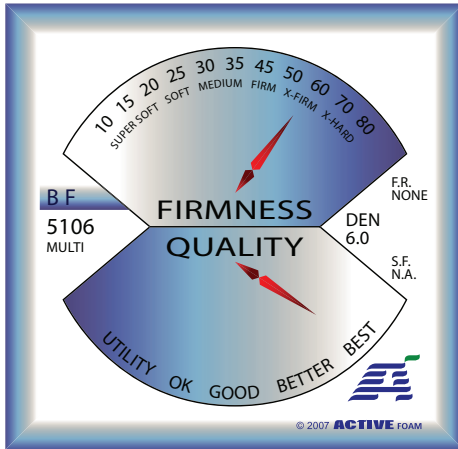

BF5106 6-LB PREMIERE BONDED

BF5108 8-LB PREMIERE BONDED

BF5109 9-LB PREMIERE BONDED

27½" X 78"

27½" X 78"

27½" X 78"

SIZES	A	B	C	D
1"	62.10	55.50	53.30	51.10
1½"	93.20	83.30	80.00	76.70
2"	124.20	111.00	106.60	102.20
2½"	155.30	138.80	133.30	127.80
3"	186.30	166.50	159.90	153.30
3½"	217.40	194.30	186.60	178.90
4"	248.40	222.00	213.20	204.40
4½"	279.50	249.80	239.90	230.00
5"	310.50	277.50	266.50	255.50
5½"	341.60	305.30	293.20	281.10
6"	372.60	333.00	319.80	306.60
7"	434.70	388.50	373.10	357.70

SIZES	A	B	C	D
1"	68.00	66.00	64.00	62.00
1½"	102.00	99.00	96.00	93.00
2"	136.00	132.00	128.00	124.00
2½"	170.00	165.00	160.00	155.00
3"	204.00	198.00	192.00	186.00
3½"	238.00	231.00	224.00	217.00
4"	272.00	264.00	256.00	248.00
4½"	306.00	297.00	288.00	279.00
5"	340.00	330.00	320.00	310.00
5½"	374.00	363.00	352.00	341.00
6"	408.00	396.00	384.00	372.00
7"	476.00	462.00	448.00	434.00

SIZES	A	B	C	D
1"	76.00	74.00	72.00	70.00
1½"	114.00	111.00	108.00	105.00
2"	152.00	148.00	144.00	140.00
2½"	190.00	185.00	180.00	175.00
3"	228.00	222.00	216.00	210.00
3½"	266.00	259.00	252.00	245.00
4"	304.00	296.00	288.00	280.00
4½"	342.00	333.00	324.00	315.00
5"	380.00	370.00	360.00	350.00
5½"	418.00	407.00	396.00	385.00
6"	456.00	444.00	432.00	420.00
7"	532.00	518.00	504.00	490.00

55" X 78"

55" X 78"

55" X 78"

1"	124.20	111.00	106.60	102.20
1½"	186.30	166.50	159.90	153.30
2"	248.40	222.00	213.20	204.40
2½"	310.50	277.50	266.50	255.50
3"	372.60	333.00	319.80	306.60
3½"	434.70	388.50	373.10	357.70
4"	496.80	444.00	426.40	408.80
4½"	558.90	499.50	479.70	459.90
5"	621.00	555.00	533.00	511.00
5½"	683.10	610.50	586.30	562.10
6"	745.20	666.00	639.60	613.20
7"	869.40	777.00	746.20	715.40

1"	136.00	132.00	128.00	124.00
1½"	204.00	198.00	192.00	186.00
2"	272.00	264.00	256.00	248.00
2½"	340.00	330.00	320.00	310.00
3"	408.00	396.00	384.00	372.00
3½"	476.00	462.00	448.00	434.00
4"	544.00	528.00	512.00	496.00
4½"	612.00	594.00	576.00	558.00
5"	680.00	660.00	640.00	620.00
5½"	748.00	726.00	704.00	682.00
6"	816.00	792.00	768.00	744.00
7"	952.00	924.00	896.00	868.00

1"	152.00	148.00	144.00	140.00
1½"	228.00	222.00	216.00	210.00
2"	304.00	296.00	288.00	280.00
2½"	380.00	370.00	360.00	350.00
3"	456.00	444.00	432.00	420.00
3½"	532.00	518.00	504.00	490.00
4"	608.00	592.00	576.00	560.00
4½"	684.00	666.00	648.00	630.00
5"	760.00	740.00	720.00	700.00
5½"	836.00	814.00	792.00	770.00
6"	912.00	888.00	864.00	840.00
7"	1064.00	1036.00	1008.00	980.00

WEIGHT EQUIPMENT FOAMS



6, 7, 9 & 10 LB BONDED

6LB, 7LB, 9LB, AND 10LB BONDED ARE THE CHOICES. OPEN CELLED FOAMS NO MATTER HOW FIRM, ARE STILL JUST AN AIRY CELL STRUCTURE. WITH THIS APPLICATION YOU NEED A FOAM WITH A LOT OF SUBSTANCE, OR A "CLOSED CELL FOAM". THESE BONDED GIVE YOU THE PERFORMANCE OF CLOSED CELL FOAMS AT A FRACTION OF THE PRICE. WITH THE DENSITY OF OVER 3 TIMES A TOP OF THE LINE URETHANE, IT WILL NOT ALLOW PIN-POINT PRESSURES OF ELBOWS AND KNEES TO BOTTOM OUT AND THEY ARE EXTREMELY DURABLE.

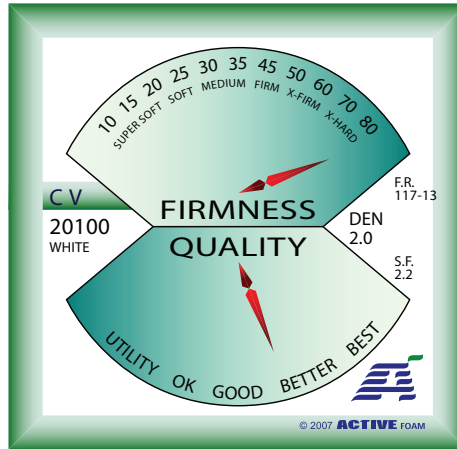
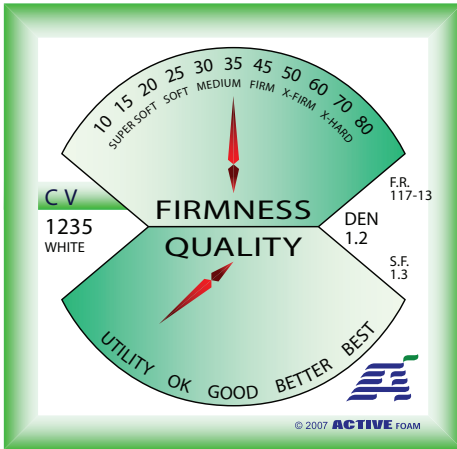

ARM & RAIL PAD FOAMS

CV20100 - FR44125 - CV25140 -
CV40155 - BF5010

GIVE YOUR WORK THAT QUALITY FEEL.

THIN PADDING APPLICATIONS REQUIRE SUPER-HARD FOAMS TO GIVE ADEQUATE SUPPORT & THE SUBSTANTIAL FEEL OF QUALITY WORK. USING ONE OF THESE FOAMS AS A BASE LAYER CAN DO THE TRICK. ADDING A FIRM OR X-FIRM FOAM OVER THIS BASE LAYER CAN GIVE YOU A SOFTER OUTER LAYER FOR THE INITIAL TOUCH OF THESE RAILS AND ARM PADDINGS.

CV1235 MEDIUM

24" X 30' ROLLS

SIZES	A	B	C	D
¼"	29.00	28.00	27.00	25.90
½"	58.00	55.90	53.90	51.80
1"	104.50	100.80	97.10	93.30
1½"	156.80	151.20	145.60	140.00
2"	191.60	184.80	177.90	171.10

27" X 30' ROLLS

¼"	32.60	31.50	30.30	29.20
½"	65.20	62.90	60.60	58.30
1"	117.60	113.40	109.20	105.00
1½"	176.40	170.10	163.80	157.50
2"	215.60	207.90	194.40	192.50

54" X 30' ROLLS

¼"	65.20	62.90	60.60	58.30
½"	130.40	125.80	121.10	116.50
1"	235.20	226.80	218.40	210.00
1½"	352.70	340.10	327.50	314.90
2"	431.10	415.70	400.30	384.90

81" X 30' ROLLS

¼"	93.90	90.50	87.20	83.80
½"	187.70	181.00	174.30	167.60
1"	337.50	325.50	313.40	301.40
1½"	506.30	488.20	470.10	452.10
2"	617.60	595.50	573.50	551.40

CV20100 S-HARD

30' ROLLS

SIZES	A	B
1/4" X 82" PER YARD	20.40	18.50
1/2" X 82" PER YARD	34.70	32.80

PLEASE NOTE
WE WILL TRIM 82" WIDE ROLLS
AT NO EXTRA CHARGE
2 ROLLS AT 41"
3 ROLLS AT 27"
4 ROLLS AT 20½"

82" SHEETS

1/2" X 24"	23.50	22.40	21.50	20.50
1" X 24"	46.90	44.80	42.90	41.00



More Information is on Pages 12-13.

- Made without ozone depleters
- Made without PBDE flame retardants
- Made without mercury, lead and other heavy metals
- Made without formaldehyde
- Made without phthalates regulated by the Consumer Product Safety Commission
- Low VOC (Volatile Organic Compounds) emissions for indoor air quality
- Tested and approved for durability and performance.

The CertiPUR-US® program is administered by a not-for-profit organization and is the most rigorous and comprehensive certification for polyurethane foam.

FOAMS THAT FEEL
GOOD
AND
YOU CAN FEEL GOOD
ABOUT

For the most complete resource on
CertiPUR-US®
go to <http://certipur.us>

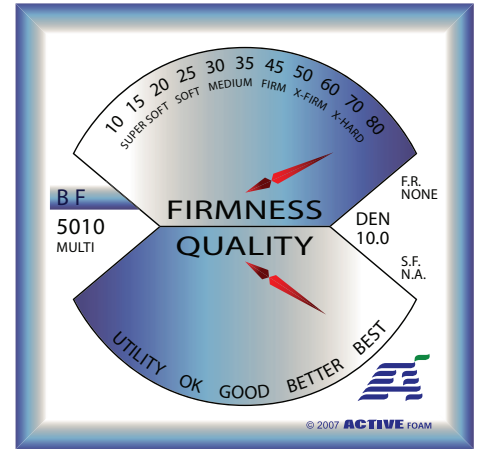
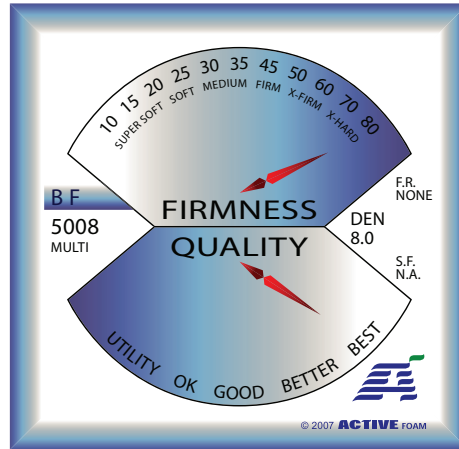
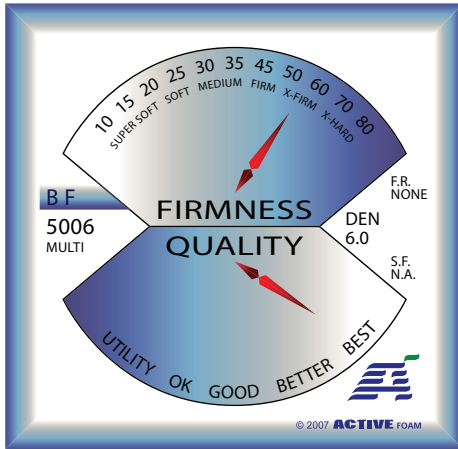

BF5006 6-LB CARPET PADDING

BF5008 8-LB CARPET PADDING

BF5010 10-LB CARPET PADDING

72" WIDE

72" WIDE

72" WIDE

15 YARD ROLLS
1/2" PER YARD

YARD
35.60

ROLL
23.60

15 YARD ROLLS
1/2" PER YARD

YARD
37.70

ROLL
25.70

15 YARD ROLLS
1/2" PER YARD

YARD
39.80

ROLL
27.80

MORE THAN A CARPET PAD.
ARM RAILS & BACK RAILS



USE WHERE YOU
NEED A
DENSE PADDING

HIGH DENSITY - SUPER HARD FOAMS

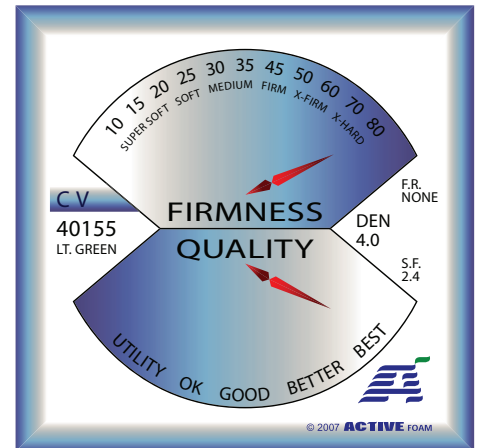
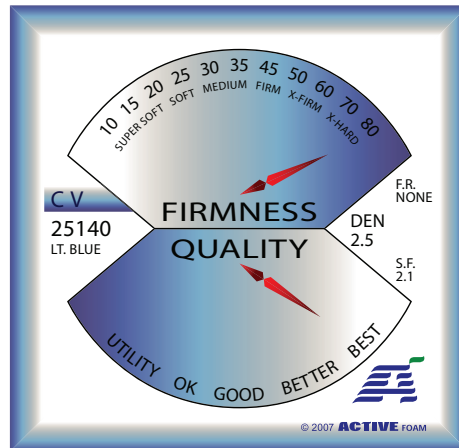
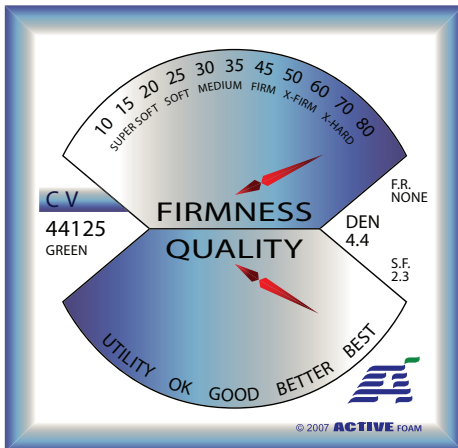

CV44125 S-HARD

CV25140 S-FIRM

CV40155 S-HARD

82" SHEETS

72" SHEETS

72" SHEETS

SIZES	A	B	C	D
1/2" X 24"	41.10	38.80	37.60	36.50
1" X 24"	82.20	77.50	75.20	72.90
1 1/2" X 24"	123.30	116.30	112.80	109.40
2" X 24"	164.40	155.00	150.40	145.80
2 1/2" X 24"	205.50	193.80	188.00	182.30
3" X 24"	246.60	232.50	225.60	218.70
3 1/2" X 24"	287.70	271.30	263.20	255.20
4" X 24"	328.80	310.00	300.80	291.60
4 1/2" X 24"	369.90	348.80	338.40	328.10

SIZES	A	B	C	D
1/2" X 24"	26.70	25.40	24.30	23.10
1" X 24"	53.40	50.70	48.60	46.20
1 1/2" X 24"	80.10	76.10	72.90	69.30
2" X 24"	106.80	101.40	97.20	92.40
2 1/2" X 24"	133.50	126.80	121.50	115.50
3" X 24"	160.20	152.10	145.80	138.60
3 1/2" X 24"	186.90	177.50	170.10	161.70
4" X 24"	213.60	202.80	194.40	184.80
4 1/2" X 24"	240.30	228.20	218.70	207.90

SIZES	A	B	C	D
1/2" X 27"	41.10	38.80	37.60	36.50
1" X 27"	82.20	77.50	75.20	72.90
1 1/2" X 27"	123.30	116.30	112.80	109.40
2" X 27"	164.40	155.00	150.40	145.80
2 1/2" X 27"	205.50	193.80	188.00	182.30
3" X 27"	246.60	232.50	225.60	218.70
3 1/2" X 27"	287.70	271.30	263.20	255.20
4" X 27"	328.80	310.00	300.80	291.60
4 1/2" X 27"	369.90	348.80	338.40	328.10

CLOTHBACKED FOAMS

WE STOCK THEM IN A VARIETY OF FOAMS TO HELP YOU BEST FIT THE JOB YOU HAVE AT HAND.

THERE ARE ALSO 4 BACKINGS:
WOVEN SCRIM, TRICOT, REMAY, & VELCRO CLOTH

THE QUALITY & FIRMNESS OF THE FOAM ARE JUST AS IMPORTANT AS YOUR CHOICE ON A THICK SEAT CUSHION.

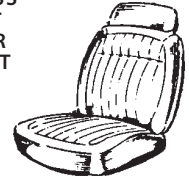

IF YOU HAVE ALWAYS THOUGHT ALL CLOTHBACKED FOAMS WERE THE SAME, THEY'RE NOT.

CV1450 WITH SCRIM

THE PRICE LEADER WITH A WOVEN SCRIM



BACKING: WOVEN SCRIM CLOTH

10 YARD ROLLS	YARD	ROLL	4 ROLLS
1/4" X 56" X YARD	17.50	13.20	12.10
1/2" X 56" X YARD	21.10	15.90	14.90
3/4" X 56" X YARD	36.50	31.00	27.90

CV1235 WITH VELCRO CLOTH

VELCRO CLOTH ACTS AS THE LOOP OF VELCRO



10 YARD ROLLS	YARD	ROLL	4 ROLLS
1/4" X 56" X YARD	29.60	24.30	22.00
1/2" X 56" X YARD	36.70	31.40	29.10

CV1570 WITH SCRIM

WHEN YOU NEED AN EXTRA-FIRM TOPPER



Its extra firmness is also Great for door panels.

10 YARD ROLLS	YARD	ROLL	4 ROLLS
1/4" X 56" X YARD	20.80	16.50	15.00
1/2" X 56" X YARD	24.20	19.00	17.50

CV1235 CHANNELED

3/4" THICK
12 YARD ROLLS

BACKING:
WOVEN SCRIM CLOTH

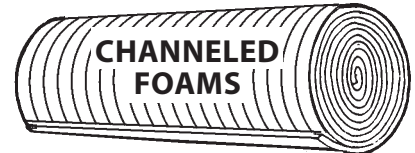

16.67 YARD ROLLS	YARD	ROLLS	4 ROLLS
1 1/2" X 54" X YARD	62.60	54.00	47.50
2" X 54" X YARD	62.60	54.00	47.50
3" X 54" X YARD	62.60	54.00	47.50
4" X 54" X YARD	62.60	54.00	47.50

FR1845 WITH SCRIM

THE BEST SEWING CLOTHBACK COMPLIES WITH MVSS-302



a subtle & flexible feel. the best for pleats & channels

10 YARD ROLLS	YARD	ROLL	4 ROLLS
1/8" X 56" X YARD	24.00	18.00	16.00
1/4" X 56" X YARD	26.20	20.50	18.90
1/2" X 56" X YARD	33.60	27.30	25.00



**QUALITY
FOAM
SOLD
HERE!**

AS A FABRICATOR OF OVER 60 FOAMS, WE KNOW THAT FOAM IS NOT JUST FOAM. IT IS OUR GOAL TO CARRY GOOD & CONSISTANT FOAMS AT EACH QUALITY RANGE.

VOLARA CLOSED CELL FOAM

IRRADIATION CROSS-LINKED, CLOSED CELL,
MICRO-CELLULAR POLYETHYLENE FOAM.



COLOR: WHITE

USES:

- SCULPTURING FOAM
- DASHBOARDS
- RESTAURANT
- GAMBLING TABLES
- VINYL ROOFS

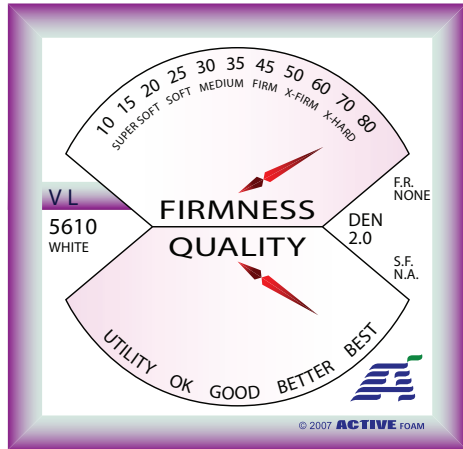

VL5610 VOLARA

CLOSED
CELL

SIZES	YD	10	25
1/8" x 60" x YD	14.40	11.40	8.90
3/16" x 60" x YD	17.90	14.90	12.40
1/4" x 60" x YD	21.30	18.30	15.80
3/8" x 60" x YD	28.20	25.20	22.70
1/2" x 60" x YD	35.10	32.10	29.60

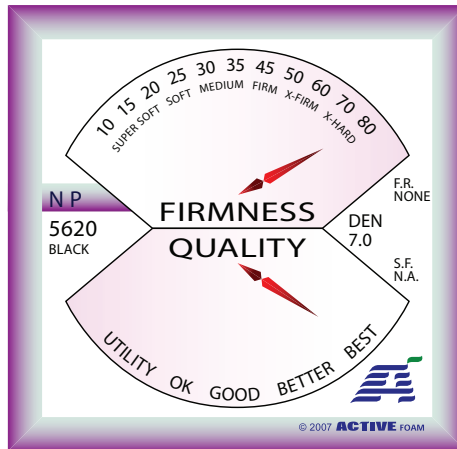

NP5620 NEOPRENE

CLOSED
CELL

48" WIDE

SIZES	YD	10	25
1/8" PER YARD	31.10	25.10	22.60
1/4" PER YARD	47.60	41.60	39.10

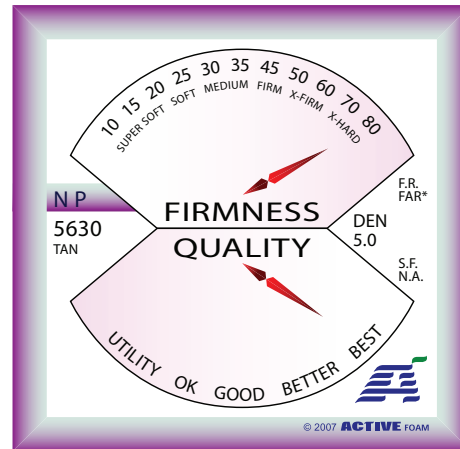

NP5630 NEOPRENE

CLOSED
CELL

24" X 60"

SIZES	EA	6
1/2" X 24" X 60" WITH CLOTHBACKING	108.80	102.00



COLOR: BLACK

TYPE: SOFT PLIABLE NEOPRENE
GASKET FOAM

USES:
GREAT FOR VINYL ROOFS

COMPLIES WITH: FAR REGULATION 25.853A
(12 SECOND VERI-
CAL TEST)



COLOR: TAN

TYPE: MEDIUM OPEN CELLED NEOPRENE

USES: SEAT TOPPERS
SEWN & QUILTED TOPPERS

CUSTOM COVERING OF MATTRESSES

YOU PICK THE SIZE

THICKNESS
WIDTH
LENGTH
OR PATTERN

YOU PICK THE FEEL

FOAM FIRMNESS
FOAM QUALITY
OR FOAM COMBO

YOU PICK THE TICKING

3/8" QUILTED COVER: BLUE
3/8" QUILTED COVER: CREAM
BLUE & WHITE STRIPE
STAPH-CHEK: 10.5OZ
HERCULEX : 8OZ

- Foam cores are quoted separately
- Fast processing: 3-6 working days
- Special shapes on a per quote basis
- Cores between 6"-10", add \$26.00

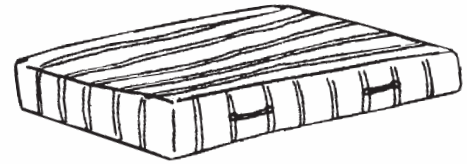

SIZE			PINSTRIPLE BLUE/WHITE	QUILTED DAMASK	HERCULEX WATER-PROOF	SC-XL WATERPROOF
TH	WD	LN				
4-6"	39"	75"	336.00	430.00	336.00	398.00
4-6"	54"	75"	398.00	542.00	378.00	440.00
4-6"	60"	80"	480.00	708.00	460.00	542.00
4-6"	76"	80"	480.00	708.00	460.00	542.00

Covering Fees are based on your sizes fitting within one of the 4 groupings.
For longer lengths, just add \$5.00 per foot.
Special patterns, please call.

FOAM MATTRESS CORES

Custom cut to your thickness, width, length, & shape.

For your convenience, we've listed some common mattress cores in various foams. Price is based on single core purchases.

- TWIN
- FULL
- QUEEN
- KING
- CAMPERS
- BOAT BERTHS

MATTRESS FIRMNESSES

30 Compression = Medium
35 Compression = Firm
40 Compression = Extra-Firm
45 Compression = Extra-Extra-Firm

HR Cores will be firmer given that scale and must be taken into account.

When covering a mattress, a 1/2 to 1 inch allowance should be added to the cores length & wide, from your desired finished size (length & width).

	CV1235	CV1835	FR2235	FR2535	FR2835	HR3133
5" X 39" X 76"	193.40	282.00	372.00	437.70	494.00	559.00
6" X 39" X 76"	232.10	338.40	446.40	525.30	592.80	670.80
5" X 54" X 80"	267.80	317.30	418.50	492.40	555.80	628.90
6" X 54" X 80"	321.30	380.70	502.20	590.90	666.90	754.70
5" X 60" X 80"	297.50	352.50	465.00	547.10	617.50	698.80
6" X 60" X 80"	357.00	423.00	558.00	656.60	741.00	838.50
5" X 76" X 80"	376.90	446.50	589.00	693.00	782.20	885.10
6" X 76" X 80"	452.20	535.80	706.80	831.60	938.60	1062.10

VISCO-ELASTIC FOAM : VE4010

NEW GENERATION. Visco-elastic Foam is a quantum leap forward ---- a whole new generation in futuristic foam for the newest dimension in comfort.

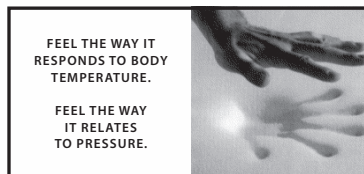

MEMORY FOAM

SLOW RECOVERY FOAM

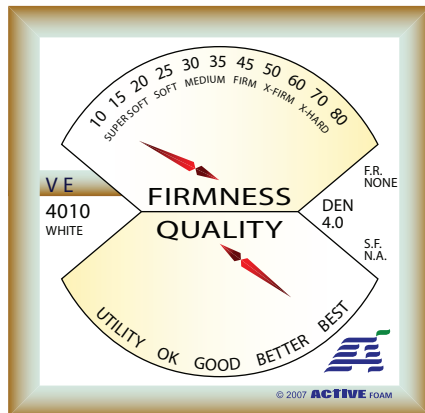

GEL-LIKE.
Visco-elastic Foam's gel-like flotation characteristics, it equalizes and redistributes pressure, so that blood circulation is normalized.

UNIQUE.
Visco-elastic foam allows you to position the mattress as truly new, truly different, and truly better.

VALUE ADDED.
In today's environment of parity products with diminishing margins, Visco-elastic Foam enables you to compete more effectively and operate more efficiently.

THERMOSENSITIVE.
"Temperature-smart" foam relaxes according to body heat and dynamics. As heat is applied, the foam molds to body contours.

CUSTOM COMFORT AND LOAD BEARING.
Open-celled visco-elastic foam responds to body dynamics, like no ordinary urethane foam or polyester fiber possibly can!

SIZES	A	B
1" X 30" X 80"	78.00	72.00
1 1/2"	117.00	108.00
2"	156.00	144.00
2 1/2"	195.00	180.00
3"	234.00	216.00
1" X 60" X 80"	156.00	144.00
1 1/2"	234.00	216.00
2"	312.00	288.00
2 1/2"	390.00	360.00
3"	468.00	432.00
1" X 76" X 80"	197.60	182.40
1 1/2"	296.40	273.60
2"	395.20	364.80
2 1/2"	494.00	456.00
3"	592.80	547.20

PS5420 2LB ESTER *WITH PSA*

- Foam Type: 2lb Ester
- Color: Charcoal
- Firmness: Firm
- Fire Retardancy: UL94

**PRESSURE SENSITIVE
ADHESIVE BACKING**

- Uses: Lining cases
- Laminate to other foams
- Backing to strengthen fabrics

	YARD	5 YARDS	10 YARDS
1/8"X54"	42.60	38.40	35.20

WARNING

URETHANE FOAM IS FLAMMABLE!

DO NOT EXPOSE URETHANE FOAMS TO OPEN FLAMES OR ANY OTHER DIRECT OR INDIRECT HIGH TEMPERATURE IGNITION SOURCES SUCH AS BURNING OPERATIONS, WELDING, BURNING CIGARETTES, SPACE HEATERS OR NAKED LIGHTS.

ONCE IGNITED, URETHANE FOAMS WILL BURN RAPIDLY, RELEASING GREAT HEAT AND CONSUMING OXYGEN AT A HIGH RATE. IN AN ENCLOSED SPACE THE RESULTING DEFICIENCY OF OXYGEN WILL PRESENT A DANGER OF SUFFOCATION TO THE OCCUPANTS. HAZARDOUS GASES RELEASED BY THE BURNING FOAM CAN LEAD TO INCAPACITATION OR BE FATAL TO HUMAN BEINGS IF INHALED IN SUFFICIENT QUANTITIES.

CLOSED CELL NEOPRENE *WITH SINGLE SIDED BLACK NYLON BACKING*

USED IN:

- SPORTS MEDICINE
- ORTHOPEDICS
- FITNESS
- EQUINE
- SPECIALTY MARKETS

FEATURES AND BENEFITS:

- HIGH RESISTANCE TO OXIDATION FOR LONGER WEAR
- EXCELLENT THERMAL INSULATIVE PROPERTIES PROVIDING WARMTH, SUPPORT AND COMFORT
- NO ODOR • CLOSED CELL, LOW MOISTURE ABSORBENCY
- PROVIDES EXCELLENT SUPPORT FOR SPORTS MEDICINE AND ORTHOPEDIC APPLICATIONS

THE "WET-SUIT" MATERIAL

** Many other fabrics and colors may be special ordered!*

FOAM TYPE: NP9640	EACH	SIX	DOZ
1/16" 1.5ML X 46" X 83"	122.60	113.80	102.20
1/8" 3.0ML X 46" X 83"	151.00	140.10	125.90

CONFOR™ ERGONOMIC URETHANE FOAMS

FIRMNESS COLOR		
CF5915	VERY SOFT	YELLOW
CF5926	SOFT	PINK
CF5934	MEDIUM	BLUE

SIZES		SHEET
1/2" X 36" X 80"		209.90
1" X 36" X 80"		419.80
1 1/2" X 36" X 80"		629.70
2" X 36" X 80"		839.60
2 1/2" X 36" X 80"		1049.50
3" X 36" X 80"		1259.40

ORDERS OVER \$350 10% DISCOUNT

CONFOR ergonomic foams, medium density, open celled polyurethane foams from E-A-R Specialty composites Corporation, offer a unique combination of physical characteristics, high energy absorption properties and temperature-softening behavior. Soft and flexible, they are suitable for highly diverse applications, from shock isolation in electronic equipment to padding and cushioning in medical devices.

CONFOR foams exhibit unusually low compression set for their low-rebound, highly damped properties, permitting loadings up to and above 50 percent compression. Their low impact resilience provides good energy absorption -- up to 97 percent without bottoming out -- while recovery from intermittent loading is gradual but complete.

Temperature-softening behavior

CONFOR Foams soften on contact with a warm surface, allowing uniform pressure distribution and firm, yet fluid, support. Because the open-celled foams are breathable, non-irritating in dermal contact, and help dissipate moisture, and perspiration away from the body, they are ideal for medical and body contact cushioning applications.

CONFOR foams' ergonomic properties make them excellent materials for occupational seating. They minimize fatigue, and in vehicle and aircraft applications, cushion against shock and vibration.

CONFOR foams' conformability and slow rate of recovery after deflection are ideal for installations where they can expand to fill a cavity and provide an effective seal. Sporting goods take advantage of CONFOR foams' durability, recovery, energy absorption and comfort. They are especially effective in cold-weather gear, remaining soft and breathable next to the body, while the outer layer provides firm support.

Versatility for design

Easily laminated to other conventional foams, fabrics and films with acrylic adhesives, CONFOR foams allow considerable design latitude for customized products. They are available in three standard stiffness grads, from very soft to firm, in thicknesses from 1/2" to 1 foot.

Broad functionality

CONFOR foams' properties offer a variety of performance advantages.

Cushioning: CONFOR foams can provide flexible protection in variety of cushioning applications, from body contact padding to electronics packaging.

Shock absorption: With their excellent energy absorption characteristics CONFOR materials offer a range of impact protection and isolation for dynamic loads, while maintaining consistent static load performance.

Sealing: CONFOR formulations conform easily to irregular shapes and surfaces to provide effective light, dust, and moisture seals.

Vibration: CONFOR foams' unique combination of slow recovery and high energy absorption allows the material to offer effective damping and vibration isolation.

Wide range of applications

CONFOR foams offer effective solutions for numerous OEM design projects.

Medical: CONFOR foams provide highly comfortable, firm support in pads for wheelchairs, operating tables, beds, neo-natal cribs, prosthetic and orthopedic devices and braces. The surface next to the body softens and conforms, while the outer surface remains firm.

Occupational/recreational:

CONFOR foams are used in seating for many fixed-wing and rotary aircraft, trucks, commercial vehicles and boats. And they provide shock absorption in rifle shoulder pads.

Athletics: CONFOR foams' durability, energy absorption and ergonomic properties are ideal for padding on gymnasium and weight-training equipment, and in helmets, braces, exercise mats and bicycle seats. Ski boots, ice skates and hiking boots take advantage of the unique temperature-softening behavior.

GELFOAM

- Health Care Seating
- Positioning Devices

GELFOAM Super Soft Comfort

A thumb is pressed deep into the GELFOAM cushion . . . and the GELFOAM memory foam retains the imprint long after the force has been removed.

Only a touch can describe the unique texture and incredible softness of GELFOAM. GELFOAM contours to the body, flowing around clothing wrinkles and seams so they are imprinted into the cushion, not into the skin. GELFOAM is a high-density, open-cell foam with gel-like properties that reduce shear forces and friction that aggravate tender areas on the skin. GELFOAM also transforms moisture and wicks it away from the body.

Sitting on a GELFOAM results in better blood circulation and improved dermatological health because it reduces pressure and relieves skin tension.

ITEM	SIZE	EACH	6
GL6805	1" X 16" X 16"	176.00	168.00

GELFOAM is a viscoelastic cushion material with open-cell structure and a soft, dough-like consistency.

GELFOAM absorbs jolts and vibrations, reducing the tiring effects of long-term seating.

GELFOAM provides flotation properties usually found only in more expensive, pure silicone gel pads.

GELFOAM is most effective when used on top of a firmer core.

GELFOAM cushions retain their soft texture in various temperature and humidity extremes. The density of a 1" GELFOAM is 33.75 lb/ft³.

GELFOAM IS NOT DESIGNED TO BE FOLDED.

VISCO-GEL

- Health Care Seating
- Motorcycle & Bike Seats
- Equestrian Pads
- Positioning Devices
- Knee & Elbow Pads
- Shock Absorbing Pads
- Wheel Chair Seats
- Snowmobile Seats

Visco-GEL is a cured polyurethane based visco-elastic polymer. Visco-GEL pads provide a cushioning that conventional open-celled, & closed-cell urethanes cannot. The advantages of the Visco-GEL are the innovative and economical options they provide the medical care industry for use as a component in customized seating and positioning. You can combine the pressure distribution qualities of our Visco-GEL with any standard seat which allows you to put the right amount of support and pressure relief where you need it most, whether in one specific area or throughout the entire seat. In addition, this latex free, incontinent-proof package can easily be rearranged, (or removed) and cleaned repeatedly without cracking or drying out.

The strength of our Visco-GEL padding comes from the quality of its components. By dielectrically sealing our Visco-GEL in polyurethane film, a superior alternative to vinyl, the exterior skin of our pad will stand up to abrasion, resist bacterial growth, clean easier and retain its original condition and performance well beyond any vinyl-skinned product. Our unique blend of heat dissipating, x-ray translucent polymers simulate the same pressure-relieving properties as human body fat which greatly reduces the risk of decubitus ulcers.

Can be cut with a razor and edges can be sealed with corn-starch.

Visco-GEL has temperature range of -40°F to +180°F.

Recommended Adhesive: VYNA-BOND

ITEM	SIZE	EACH	6
VG6810	½" X 14" X 19"	139.80	131.40
VG6810	½" X 19" X 19"	186.10	177.70

SHREDDED FOAM

Shredded Foam is the most economical stuffing available. To guard against the lumpy surface against the covering fabric, try making a pocket out of a Bonded Fiberfill or a Sewn Dacron. Just stuff the Shredded Foam fill in and get the best of both worlds.

The utility pillow filler

FOAM	SIZE	1 (20 LBS)	4 (80 LBS)	12 (240 LBS)	20 LB BAGS
MS7810	URETHANE FOAMS	3.60	3.20	2.70	(APPROXIMATE)
MS7812	VISCO ELASTIC FOAMS	4.20	3.80	3.30	PRICED PER LB
MS7814	LATEX FOAM	5.00	4.60	4.10	

FOAM SKINS

Great as an economical spring insulator

If we are to pick them out for you we will pick skins that will range in thickness from ¾" up to 1½". Because of their obvious inconsistent nature, the range can vary. However, if you come down to our warehouse, you may pick thickness of your choice.

FOAM	SIZE	EACH	DOZEN	4 DOZEN
MS7820	24" X 80"	10.00	9.00	8.50

BEAN BAG FILL

POLY-STYRENE BEADS

EP6400 Poly-Styrene Beads, or better known as "Bean Bag Fill" is a economical filler.

Orders shipped by UPS will be shipped in boxes.

FOAM	SIZE	1	2	4
EP6400	10 CUBIC FOOT BAGS	60.20	55.80	52.20
	SHIPPING BOX (IF REQUIRED)	14.00		

FABRICATING FOR MARINE SEATING

- Profile Cutting
- Pattern Cutting
- Wedged Profile Cutting
- Beveled Front Edges
- Prototype Assistance
- Quick 1-4 Day Delivery

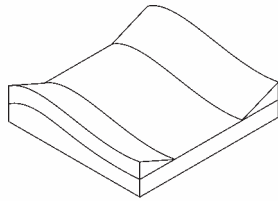

FABRICATING FOR ATHLETIC EQUIPMENT

- Bonded Foam Cut-to-Size
- Profiles for Positioning Pieces
- Closed-Cell Foams
- Contoured Foams
- Quick 1-4 Day Delivery
- 50+ Foam Selection



FABRICATING FOR THEATER SEATING

- Profile Cutting
- Pattern Cutting
- Prototype Assistance
- Quick 1-4 Day Delivery
- Fire Retardant Foams
- Optional On-Site delivery

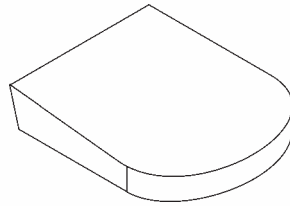

FABRICATING FOR TECHNICAL APP'S

- Profile Cutting
- Pattern Cutting
- Multi-Piece Constructions
- Prototype Assistance
- Quick 1-4 Day Delivery
- 50+ Foam Selection

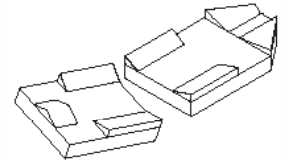

FABRICATING FOR CHURCHES

- Slabs Cut-to-Size
- Wedged Profile Seat & Backs
- 10Lb Bonded Kneelers
- Quick 1-2 Day Delivery
- Wrap Around Profiled Front Edges

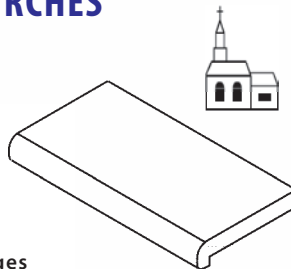

FABRICATING FOR CONSUMER PRODUCTS

- Profile Cutting
- Pattern Cutting
- Multi-Piece Assemblies
- Beveled & Buffed Edges
- Prototype Assistance
- Quick 1-4 Day Delivery

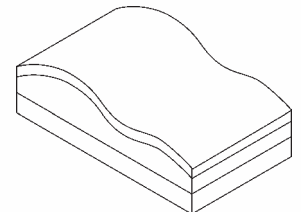

FABRICATING FOR MODERN DESIGN

- Profile Cutting
- Pattern Cutting
- Wedged Profile Cutting
- Prototype Assistance
- Quick 1-4 Day Delivery
- 50+ Foam Selection

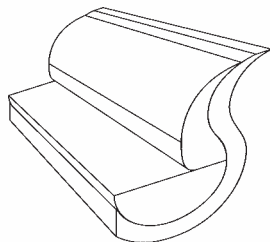

FABRICATING FOR NOVELTY ITEMS

- All Foam Furniture
- Large All Foam "Numbers"
- Large All Foam "Letters"
- Profile Your Custom Pieces
- Prototype Assistance
- Quick 1-4 Day Delivery

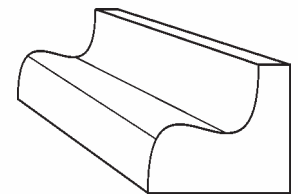

FABRICATING FOR BOOTHS

- Wedge Profile Seats & Backs
- Beveled Front Edges
- Neck Roll Profile Cutting
- Slab Cut-to-Size
- Quick 1-4 Day Delivery
- 50+ Foam Selection

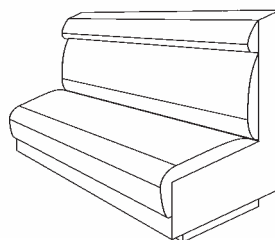

FABRICATING FOR MEDICAL PRODUCTS

- Anti-Microbial Foams
- Slow Recovery Foams
- Closed Cell Foams
- Neoprene with Nylon Laminates
- Contoured Positioning Pieces

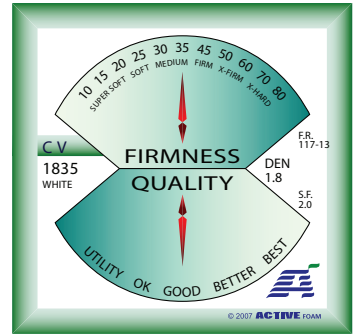
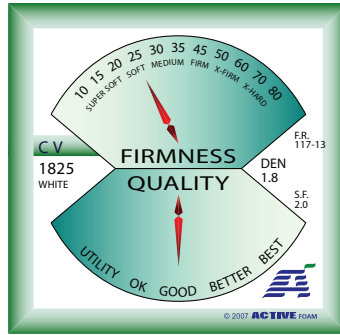
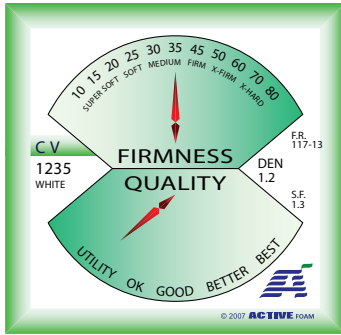
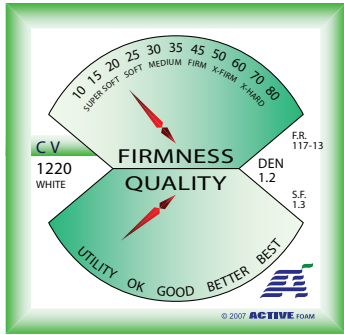

CV1220 SOFT

CV1235 MEDIUM

CV1825 SOFT

CV1835 MEDIUM

SIZES
4" X 8" X 12" X 37"
5" X 9" X 12" X 37"

1	2	4
52.80	44.90	40.80
58.60	50.10	45.60

SIZES
4" X 8" X 12" X 37"
5" X 9" X 12" X 37"

1	2	4
58.20	50.90	47.40
64.90	57.10	53.30

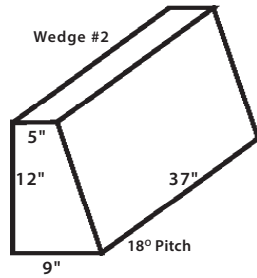
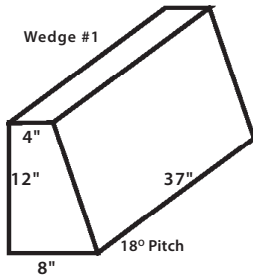

"Soft Options"
for the comfort back cushion feel. Softs are often overlooked, when they actually make the best choice, for most applications.

"Medium Options"
for the firm back feel. Will create the crisp filled out look.

"Utility" Options: #1220 or #1235 Medium - The #1200's are your choice when your budget minded and just need a bolster for looks & functionality.

"Better" Option: #1825 or #1835 Medium - The 1800's will give you reasonable comfort and longevity.

BOLSTERS MAY BE CUT OUT OF MANY OTHER FOAMS

DISCOUNTS: 5% AT \$150, 10% AT \$250, 15% AT \$400

WEDGE BOLSTERS *CUSTOM*

MAY BE CUT OUT OF MANY FOAMS

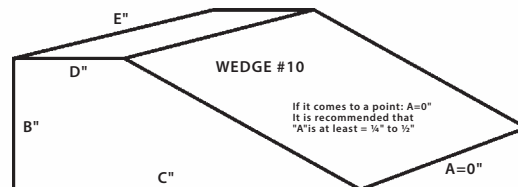
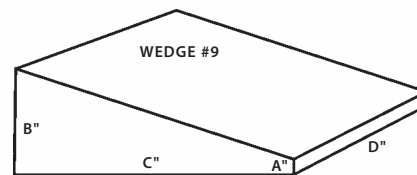
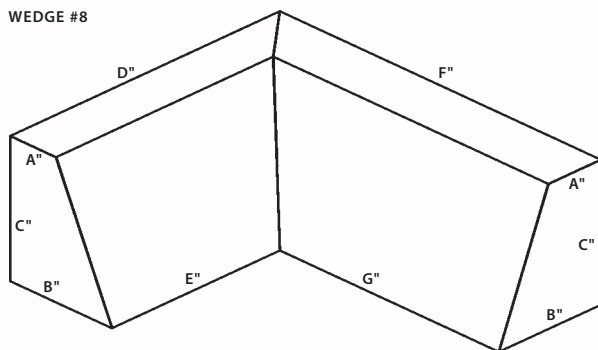
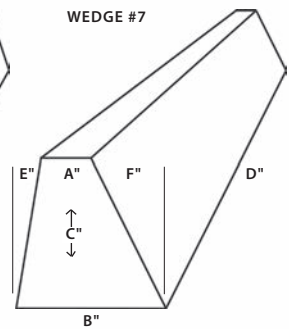
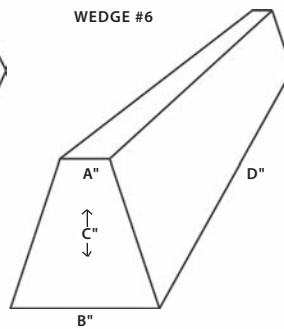
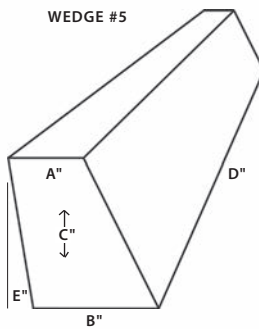
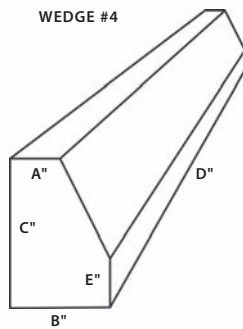
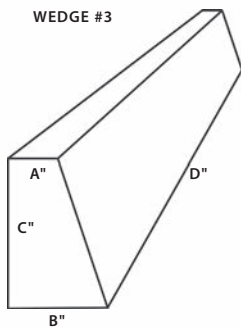

TRIANGLE BOLSTERS

RIGHT TRIANGLE

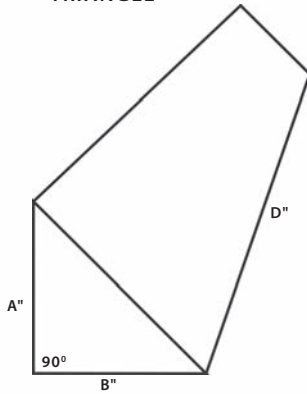

ISOSCELES TRIANGLE

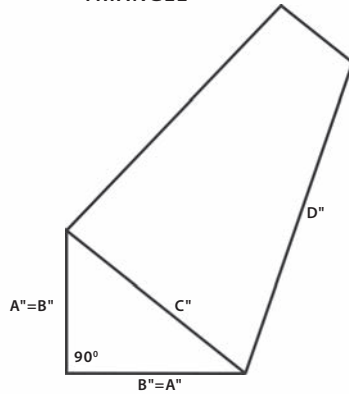

EQUALATERAL TRIANGLE

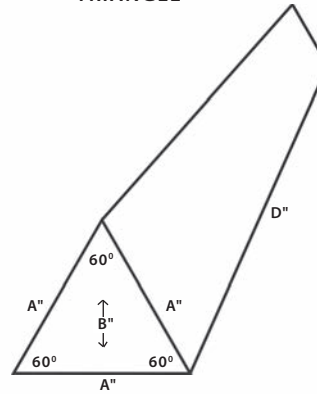

SCALENE TRIANGLE

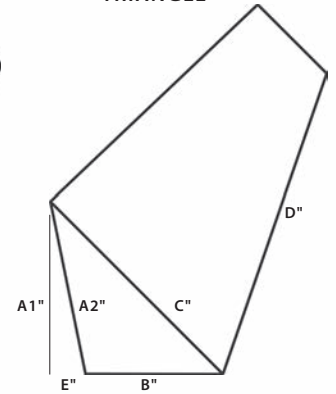

WEDGE BOLSTERS: MITRED CORNER GUIDE

90 DEGREE CORNER

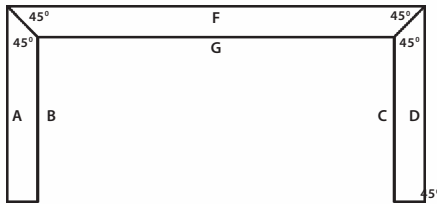

45 DEGREE OUTSIDE CORNER WITH 45 DEGREE ENDS

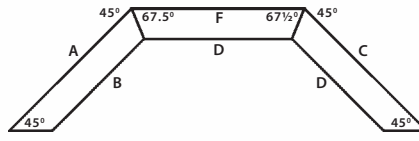

45 DEGREE OUTSIDE CORNER WITH 90 DEGREE ENDS

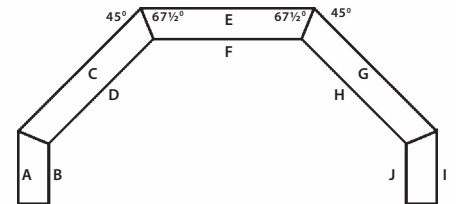

FRONT RAIL WEDGES: 10 LB BONDED

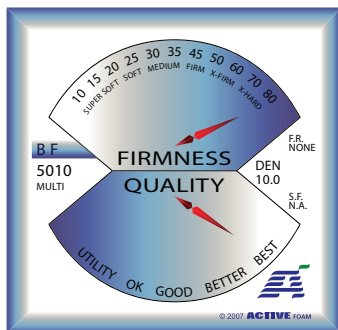

BF5010 X-HARD

Other foams can be used for this application, however the BF5010 is the most effective foam to custom cut for this use.

Wedge #11

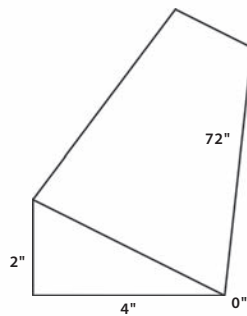

Wedge #12

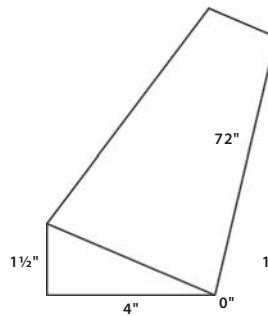

Wedge #13

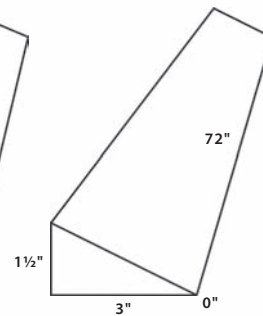

Wedge #14

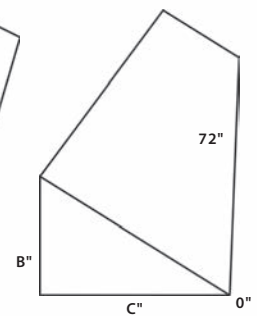

SIZES

0"	X	1 1/2"	X	3"	X	72"
0"	X	1 1/2"	X	4"	X	72"
0"	X	2"	X	4"	X	72"

1	6	12	24
11.50	10.70	8.50	7.30
13.20	12.30	10.00	8.70
15.40	14.30	12.00	10.60

ROUND BOLSTERS

- FULL
- 3 QUARTER
- HALF
- QUARTER

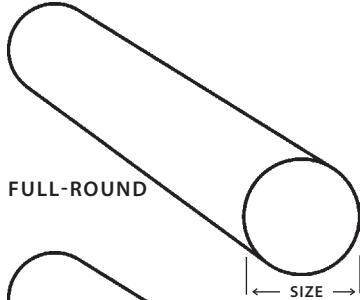

FULL-ROUND

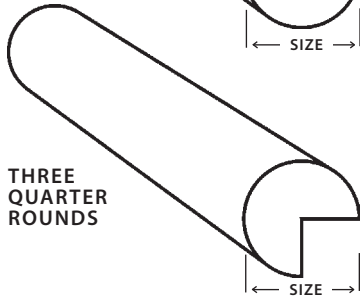

THREE QUARTER ROUNDS

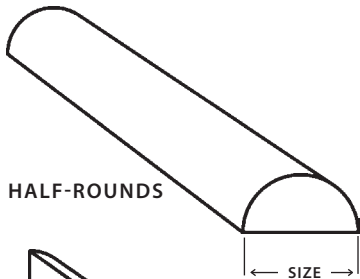

HALF-ROUNDS

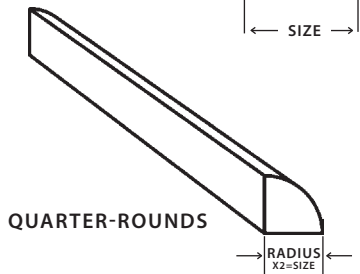

QUARTER-ROUNDS

BOLSTERS MAY BE CUT OUT OF MANY OTHER FOAMS

DIAMETERS OF 1/8" INCREMENTS CAN BE CUT

DISCOUNTS : 5% AT \$150, 10% AT \$250, 15% AT \$400

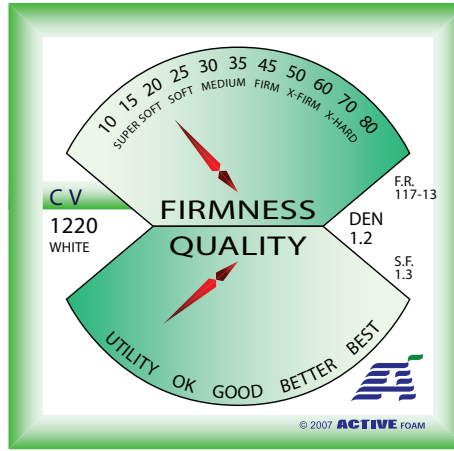

CV1220 SOFT

SIZES	QUARTER ROUNDS	
	PER LENGTH (4)	PER LENGTH (2)
3" DIAMETER X 48"	9.90	17.70
4" DIAMETER X 48"	11.30	20.60
5" DIAMETER X 48"	13.10	24.10
6" DIAMETER X 48"	15.10	28.10
7" DIAMETER X 48"	17.30	32.60
8" DIAMETER X 48"	19.70	37.40
9" DIAMETER X 48"	22.70	43.30
10" DIAMETER X 48"	25.50	49.00
11" DIAMETER X 48"	28.70	55.40
12" DIAMETER X 48"	32.40	62.80

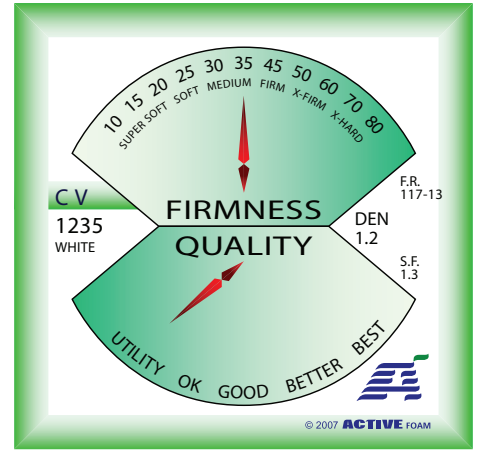

CV1235 MEDIUM

SIZES	THREE QTR ROUNDS		FULL ROUNDS	
	PER LENGTH (2)	PER LENGTH	PER LENGTH (2)	PER LENGTH
3" DIA X 48"	17.70	31.40	17.70	31.40
4" DIA X 48"	20.60	37.20	20.60	37.20
5" DIA X 48"	24.10	44.10	24.10	44.10
6" DIA X 48"	28.10	52.20	28.10	52.20
7" DIA X 48"	32.60	61.10	32.60	61.10
8" DIA X 48"	37.40	70.80	37.40	70.80
9" DIA X 48"	43.30	82.50	43.30	82.50
10" DIA X 48"	49.00	93.90	49.00	93.90
11" DIA X 48"	55.40	106.80	55.40	106.80
12" DIA X 48"	62.80	121.50	62.80	121.50

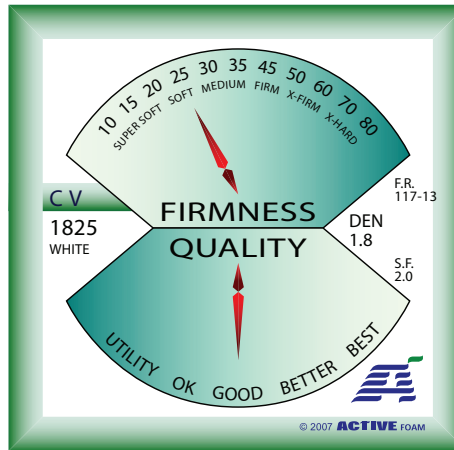

CV1825 SOFT

SIZES	QUARTER ROUNDS	
	PER LENGTH (4)	PER LENGTH (2)
3" DIA X 48"	10.50	19.00
4" DIA X 48"	12.20	22.40
5" DIA X 48"	14.30	26.50
6" DIA X 48"	16.70	31.30
7" DIA X 48"	19.30	36.60
8" DIA X 48"	22.20	42.30
9" DIA X 48"	25.60	49.20
10" DIA X 48"	29.00	56.00
11" DIA X 48"	32.80	63.60
12" DIA X 48"	37.20	72.40

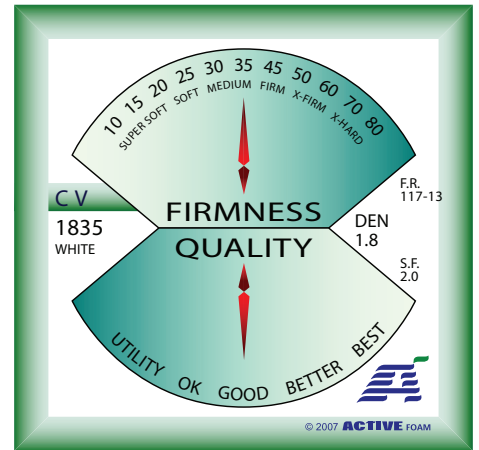

CV1835 MEDIUM

SIZES	THREE QTR ROUNDS		FULL ROUNDS	
	PER LENGTH (2)	PER LENGTH	PER LENGTH (2)	PER LENGTH
3" DIA X 48"	19.00	33.90	19.00	33.90
4" DIA X 48"	22.40	40.80	22.40	40.80
5" DIA X 48"	26.50	49.00	26.50	49.00
6" DIA X 48"	31.30	58.50	31.30	58.50
7" DIA X 48"	36.60	69.10	36.60	69.10
8" DIA X 48"	42.30	80.60	42.30	80.60
9" DIA X 48"	49.20	94.40	49.20	94.40
10" DIA X 48"	56.00	108.00	56.00	108.00
11" DIA X 48"	63.60	123.20	63.60	123.20
12" DIA X 48"	72.40	140.80	72.40	140.80

ROUND BOLSTERS *MITRED CORNER GUIDE*

90 DEGREE CORNER

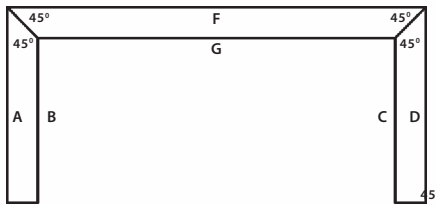

45 DEGREE OUTSIDE CORNER
WITH 45 DEGREE ENDS

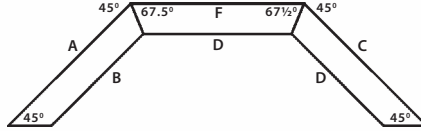

45 DEGREE OUTSIDE CORNER
WITH 90 DEGREE ENDS

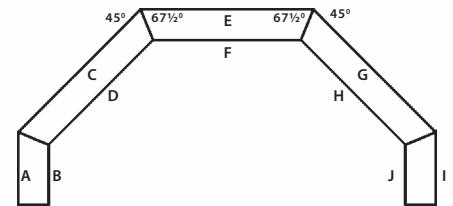

CUSTOM BOLSTERS

YOUR CUSTOM SHAPE • YOUR CHOICE OF FOAM

BOLSTER #1

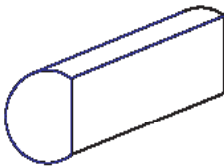

BOLSTER #2

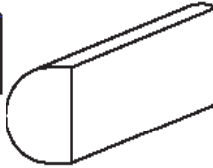

BOLSTER #3

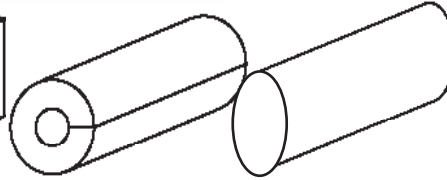

BOLSTER #4

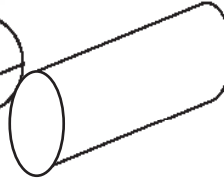

BOLSTER #5

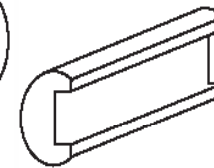

BOLSTER #6

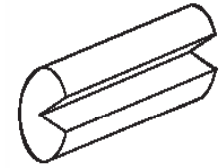

GEOMETRIC SHAPES

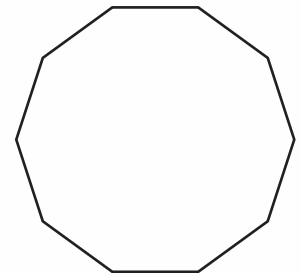
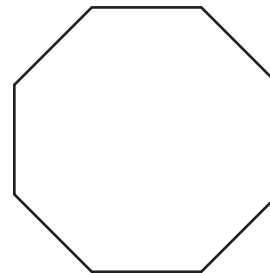
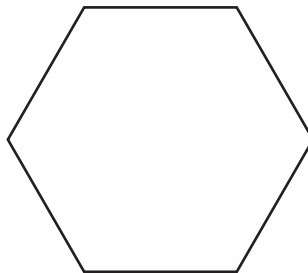
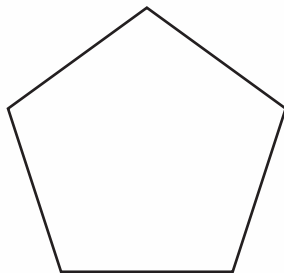

SPECIALTY SHAPES

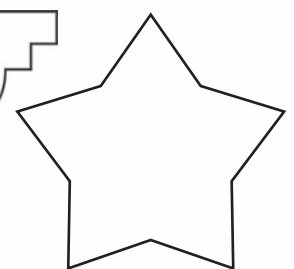
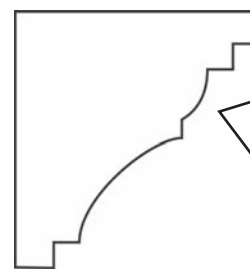
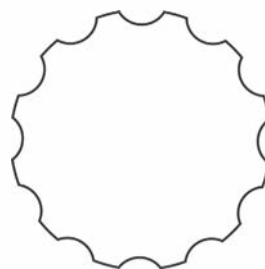
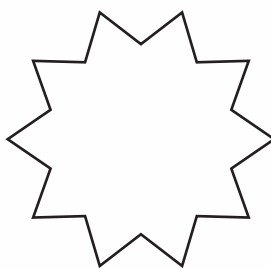
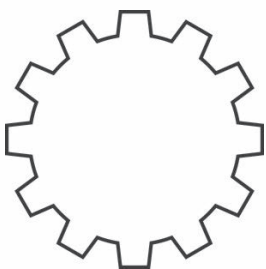

BUBBLE WRAP

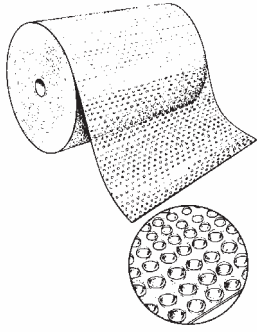

BW5710

FULL ROLLS ONLY

4 standard cell sizes of bubble wrap are available to design the package you need to eliminate or reduce shipping damage caused by shock, vibration and abusive handling.

The air-filled cells protect your articles from shipping hazards.

Flexible, lightweight bubble-wrap--

- Easy to use
- Reduces material costs
- Cuts labor costs
- Lowers shipping costs

Bubble-wrap can be engineered to meet your specific requirements by slitting, perforating or sheeting.

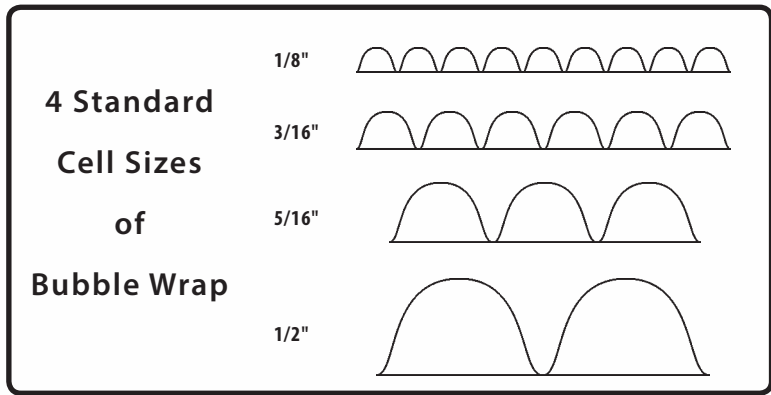

PRODUCT	BUNDLE THICKNESS	PRICE PER LENGTH	PRICE PER LINEAL YD	48" WIDTH
LD-125	1/8"	1000'	(4,000 SQ.FT.) \$1.51	\$582.20
LD-187	3/16"	750'	(3,000 SQ.FT.) \$1.51	\$436.60
LD-312	5/16"	375'	(1,500 SQ.FT.) \$2.08	\$300.30
LD-500	1/2"	250'	(1,000 SQ.FT.) \$2.11	\$203.30

POLYETHYLENE WRAP

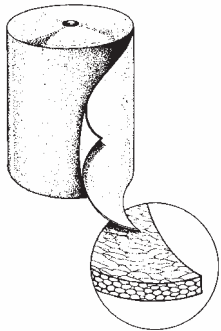

PW5720

FULL ROLLS ONLY

Polyethylene Wrap is a low cost, flexible, all-purpose material useful in both packaging and non-packaging applications. Strong, non-abrasive, lightweight and resilient, with excellent tear resistance and puncture resistance. Density: 1.2lb. 1/2" Rolls: 1.7lb.

- Polyethylene Wrap
- Strong: Outperforms the competitions
- Excellent insulating properties
- Closed Cell - superior water protection
- Non-toxic and inert
- Ozone Safe - Mfg without CFC's
- Non-Abrasive - will not scratch
- Buoyant - Approved by U.L.
- Clean - Non-dusting and lint free



PRODUCT	THICKNESS	BUNDLE LENGTH	PRICE PER LINEAL YD	PRICE PER 48" ROLL
PEW-030	1/32"	2,000'	\$.93	(8,000 SQ.FT.) \$617.00
PEW-060	1/16"	1,250'	\$1.38	(5,000 SQ.FT.) \$574.40
PEW-090	3/32"	750'	\$1.97	(3,000 SQ.FT.) \$491.40
PEW-125	1/8"	550'	\$2.47	(2,200 SQ.FT.) \$453.40
PEW-187	3/16"	350'	\$4.52	(1,400 SQ.FT.) \$526.90
PEW-250	1/4"	250'	\$5.33	(1,000 SQ.FT.) \$444.00

PE: 2LB POLY-LAM

PL5520 CHARCOAL

2" Extruded Polyethylene Plank
Heat Laminated to Plank Thickness

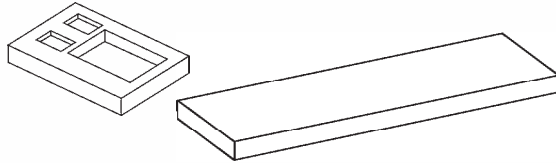

SEMI-RIGID

- ◆ Packaging Applications
- ◆ Hot Tub Insulated Covers
- ◆ Special Seating Platforms
- ◆ Bumper Inserts
- ◆ Case Inserts
- ◆ Flotable Insert

SIZES	A	B	C	D
½" x 24" x 108"	32.00	29.00	27.00	25.00
1" x 24" x 108"	64.00	58.00	54.00	50.00
2" x 24" x 108"	128.00	116.00	108.00	100.00
½" x 48" x 108"	64.00	58.00	54.00	50.00
1" x 48" x 108"	128.00	116.00	108.00	100.00
2" x 48" x 108"	256.00	232.00	216.00	200.00

PE: 1.7 POLY-LAM

PL5517 WHITE

Extruded 1/2" Polyethylene
Heat Laminated to Plank Thickness

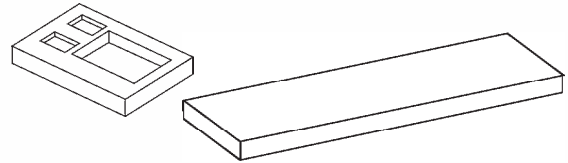

SEMI-RIGID

- ◆ Packaging Applications
- ◆ Hot Tub Insulated Covers
- ◆ Special Seating Platforms
- ◆ Bumper Inserts
- ◆ Case Inserts
- ◆ Flotable Insert

SIZES	A	B	C	D
½" x 24" x 108"	30.50	27.50	25.50	23.50
1" x 24" x 108"	61.00	55.00	51.00	47.00
2" x 24" x 108"	122.00	110.00	102.00	94.00
½" x 48" x 108"	61.00	55.00	51.00	47.00
1" x 48" x 108"	122.00	110.00	102.00	94.00
2" x 48" x 108"	244.00	220.00	204.00	188.00

2LB ESTER

PS5420 CHARCOAL SLAB STOCK & CUT-TO-SIZE

SOUND & VIBRATION DEADENING

- ◆ Packaging Applications
- ◆ Case Inserts
- ◆ Industrial Applications
- ◆ Sound Deadening Panels
- ◆ Sound Deadening Inserts

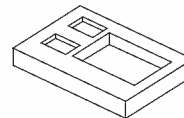

SIZES	A	B	C	D
½" x 27" x 108"	37.70	33.70	32.30	31.00
1" x 27" x 108"	75.40	67.40	64.60	61.90
1½" x 27" x 108"	113.10	101.10	96.90	92.90
2" x 27" x 108"	150.80	134.80	129.20	123.80
2½" x 27" x 108"	188.50	168.50	161.50	154.80
3" x 27" x 108"	226.20	202.20	193.80	185.70
½" x 54" x 108"	75.40	67.40	64.60	61.90
1" x 54" x 108"	150.80	134.80	129.20	123.80
1½" x 54" x 108"	226.20	202.20	193.80	185.70
2" x 54" x 108"	301.60	269.60	258.40	247.60
2½" x 54" x 108"	377.00	337.00	323.00	309.50
3" x 54" x 108"	452.40	404.40	387.60	371.40

SPECIAL SHAPING & MORE....

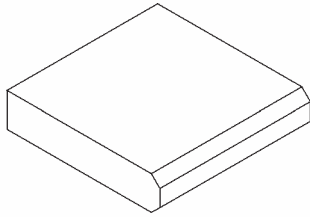

**BUFFING
&
EDGING**

**SPECIAL
CUT-OUT
BOLSTERS**

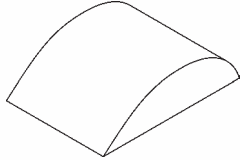
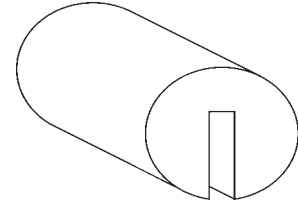

**PROFILE
CUTTING**

**BEVELED
SLABS**

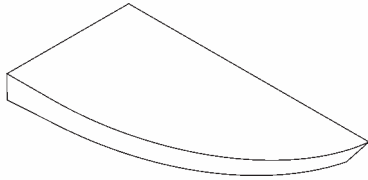
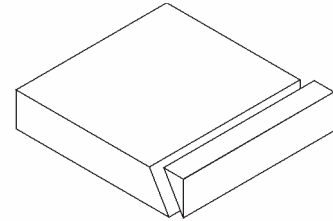

**BEVELED
BOAT
CUSHIONS**

**CONICAL &
BEVELED
CIRCLES**

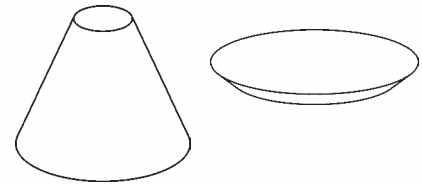

FABRICATING TO BRING SAVINGS TO YOU

Just Because it is "Simple" Fabricating that you could do yourself,
doesn't mean we can't bring a SAVINGS to You.

Let our Fast & Efficient Fabricating - Save Time & Money for You.

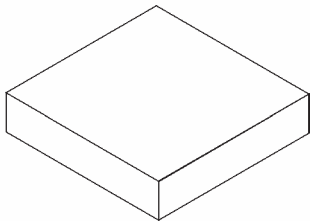

**SIMPLE RECTANGLES
&
SIMPLE SQUARES**

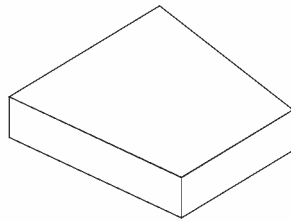

**SIMPLE TRAPAZOIDS
&
SIMPLE PATTERNS**

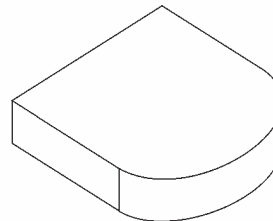

**SIMPLE "D" SHAPES
&
ROUNDED RECTANGLES**

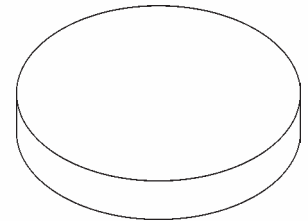

**SIMPLE CIRCLES
&
SIMPLE OVALS**

FABRICATING UNLIMITED THICKNESSES

	1/4"	1/2"	3/4"	1"	1 1/4"	1 1/2"	1 3/4"	2"	2 1/4"	2 1/2"	2 3/4"
3"	3 1/4"	3 1/2"	3 3/4"	4"	4 1/4"	4 1/2"	4 3/4"	5"	5 1/4"	5 1/2"	5 3/4"
6"	6 1/4"	6 1/2"	6 3/4"	7"	7 1/4"	7 1/2"	7 3/4"	8"	8 1/4"	8 1/2"	8 3/4"
9"	10 1/4"	11 1/2"	12 3/4"	13"	14 1/4"	15 1/2"	16 3/4"	17"	18 1/4"	19 1/2"	20 3/4"

The catalog and mailings can only list so many thicknesses. On nearly every foam, we can cut to virtually any thickness. We can cut full pieces 12" thick, or even 30" in increments of 1/16". Processing time is just as fast as the standard listed thicknesses throughout the foam section.

BUFFED EDGES

Examples: Front Edges: Top & Bottom
Top Edges: Front, Back & Sides

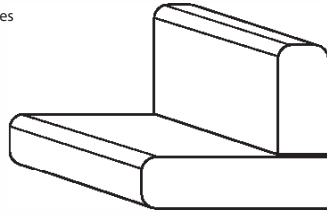
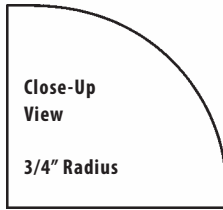

Please Call for Quotes

BEVELING

You Specify The Amount From
Corner to Cut

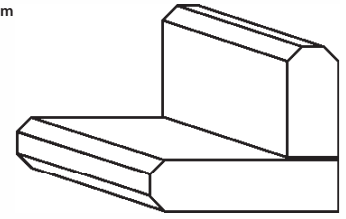
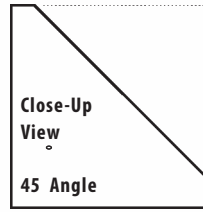

Examples: Front Edges: Top & Bottom
Top Edges: Front, Back & Sides

Please Call for Quotes

MITRED CORNER: TOP VIEW

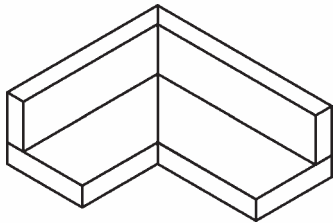

Please Call for Quotes

MITRED CORNER: SEAT TO BACK

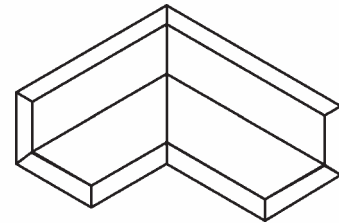

Please Call for Quotes

ROUNDED FRONT

To get an exact rounded edge, gluing a Half-Round or Half-Oval to a cushion core works like a dream. This technique utility becomes apparent as your quantity goes up.

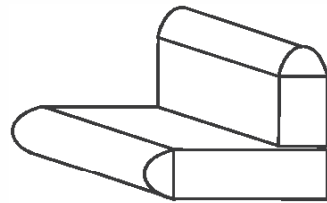

Please Call for Quotes

ROUNDED CORNERS

You specify the diameter to which you want the corners rounded. You also need to specify which corners you want rounded.

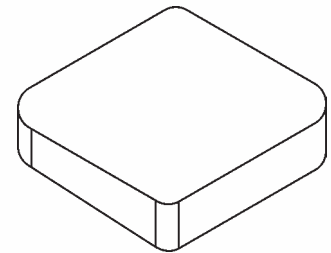

Please Call for Quotes

CUSTOM COSSACK & OTTOMAN SHAPING

You pick the foam. You create the shape, & we'll do the rest.

Whether its an all foam ottoman or a foam insert on a frame.

Call for pricing on your specific pattern or design.

CUBES

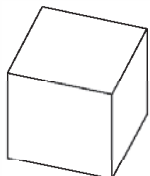

PATTERNS

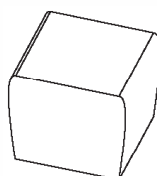

PROFILES

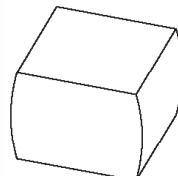

CIRCLES & ELIPSES

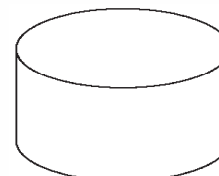

FREE FORM

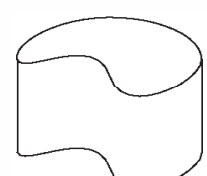

BACK RECTANGULAR BOLSTERS

SIDE VIEWS

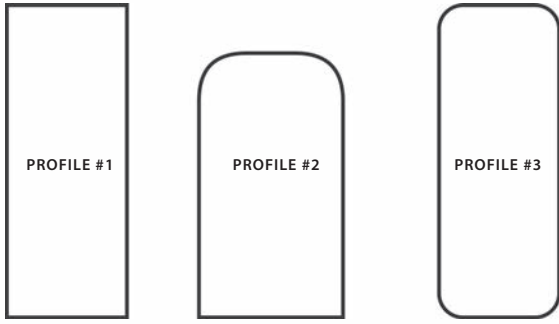

BACK WEDGE BOLSTERS

SIDE VIEWS

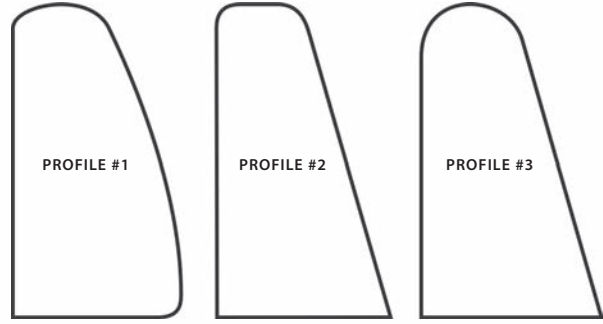

BACK SKEWED RECTANGLES

SIDE VIEWS

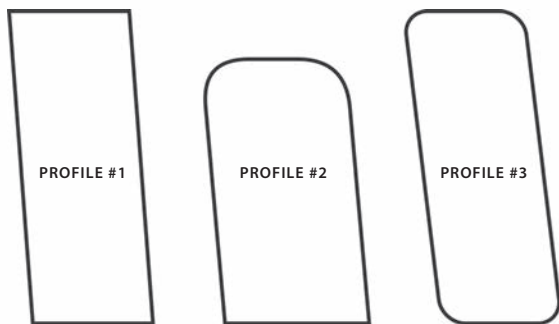

BACK SKEWED WEDGES

SIDE VIEWS

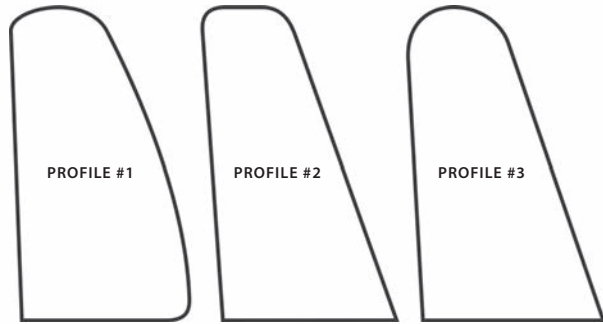

BACK OVAL BOLSTERS

SIDE VIEWS

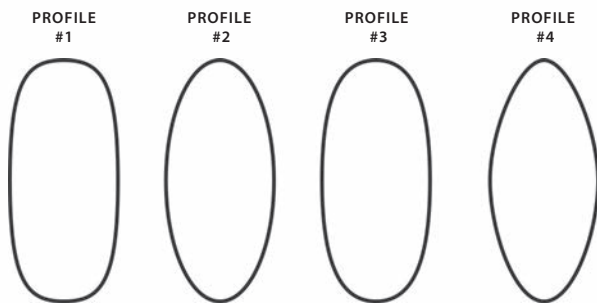

BACKS CURVED

SIDE VIEWS

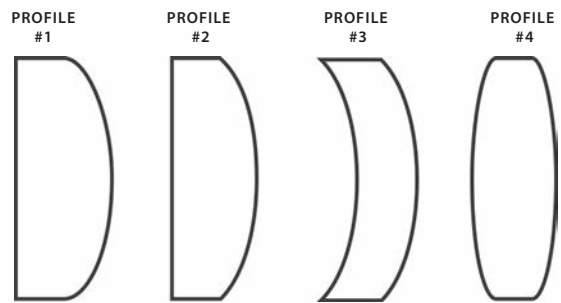

BAR RAILS

SIDE VIEWS

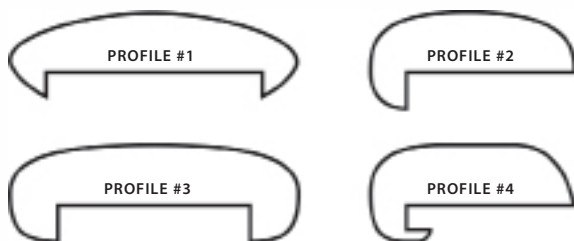

BED WEDGES

SIDE VIEWS

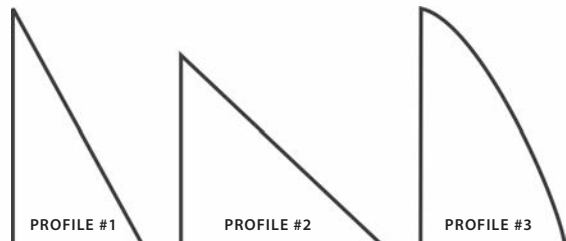

BOOTH BACKS

SIDE VIEWS

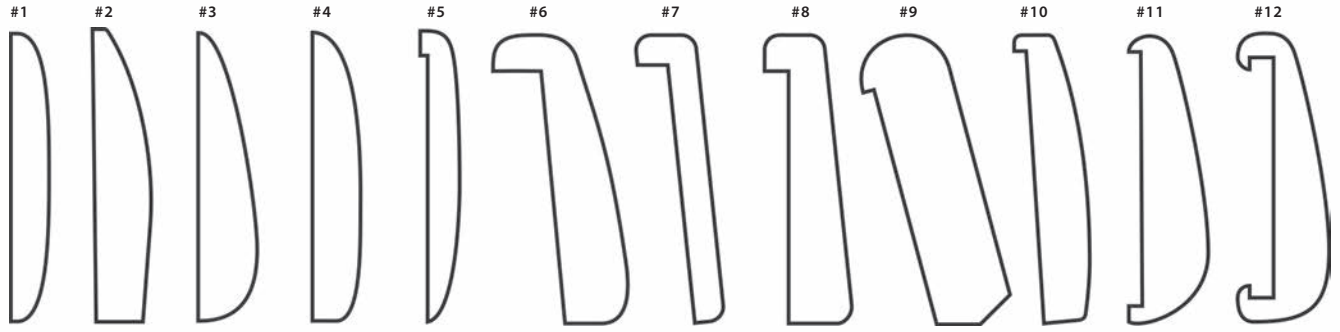

BOOTH BACKS

SIDE VIEWS

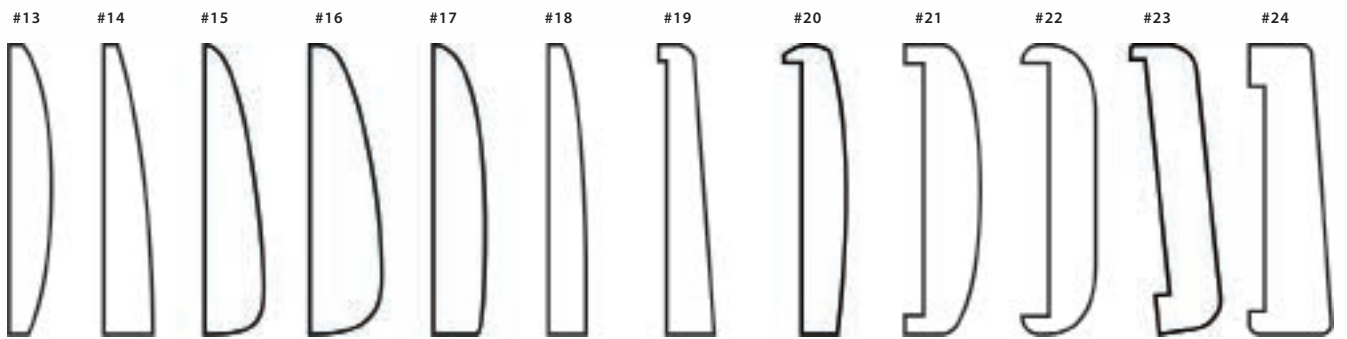

BOOTH SEATS

SIDE VIEWS

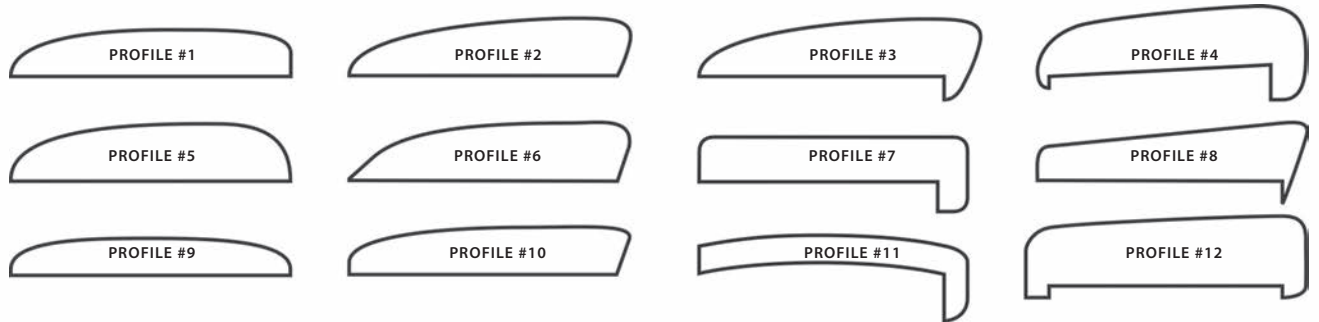

BOOTH SEATS

SIDE VIEWS

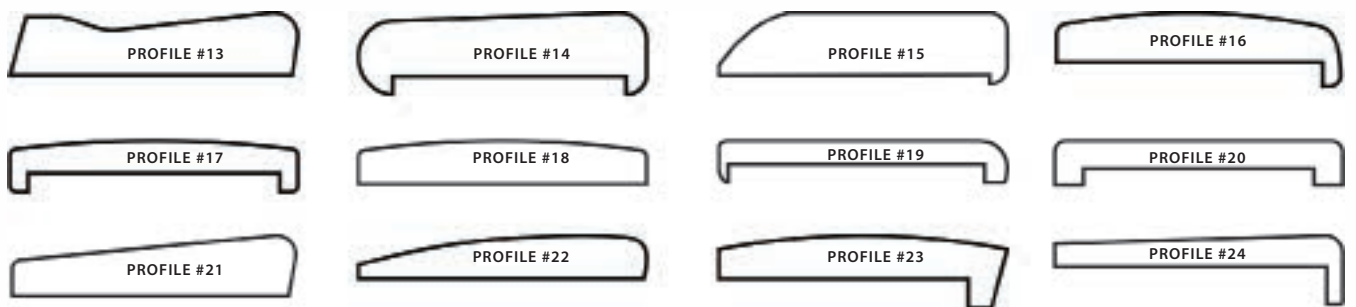

BOOTH CHANNELS

SIDE VIEW OF HORIZONTAL CHANNELS
TOP VIEW OF VERTICAL CHANNELS

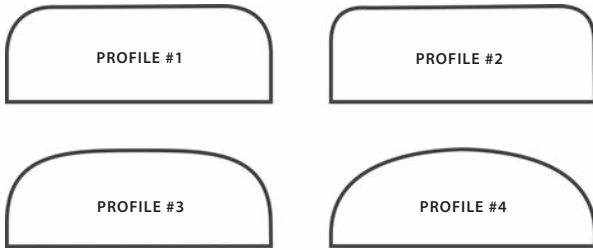

CHURCH PEWS

SIDE VIEWS

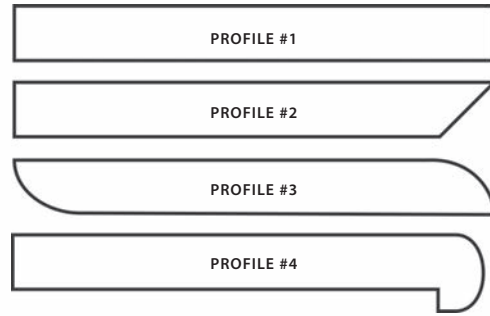

CORNICE BOARDS

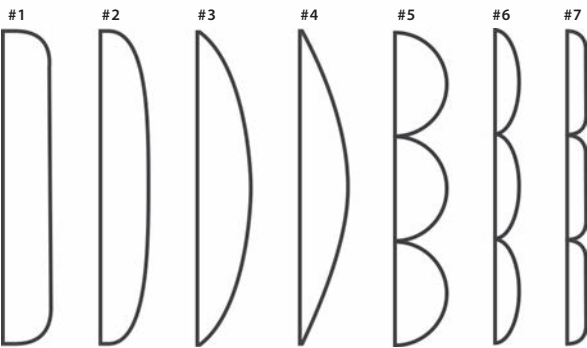

DRAPERY RODS

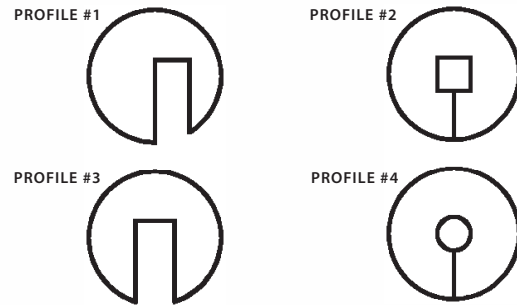

HEADBOARDS

SIDE VIEWS

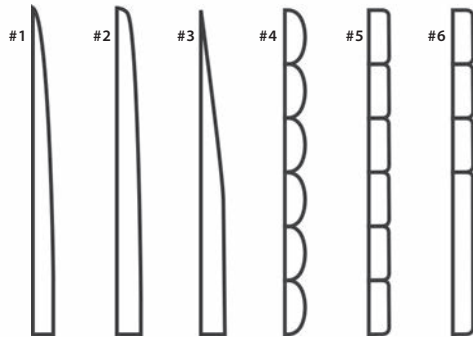

HEADRESTS

SIDE VIEWS

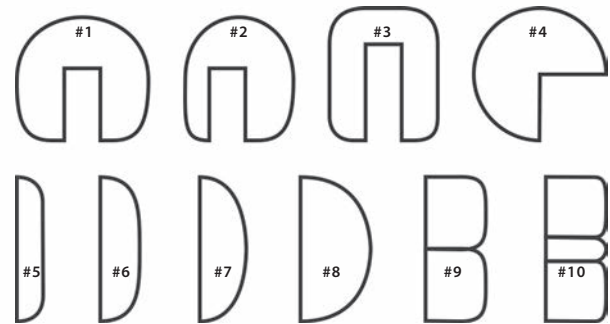

LUMBAR CUSHIONS

SIDE VIEWS

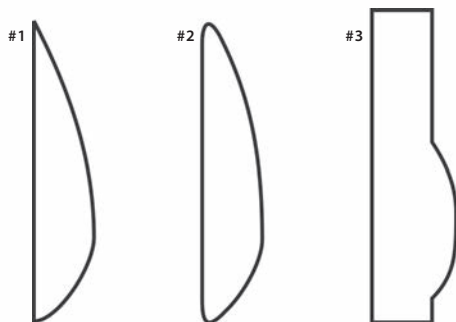

MARINE BACKS

SIDE VIEWS

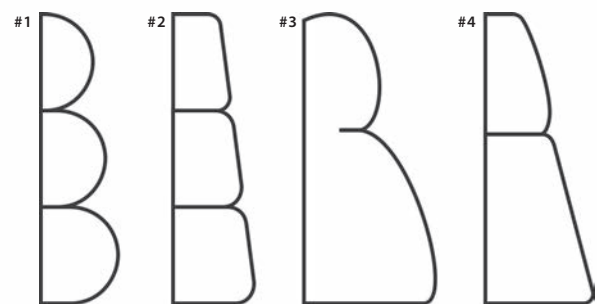

MARINE BERMS

SIDE VIEW OF BERM

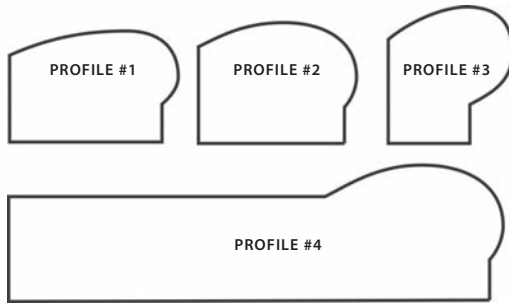

MARINE SEATS

SIDE VIEW OF CUSHION

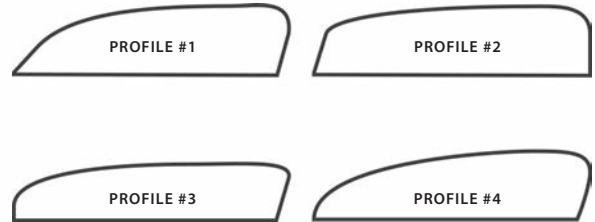

OTTOMANS

TOP VIEW OF CORE

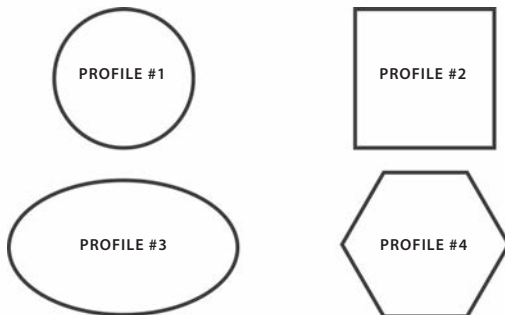

NECK ROLLS

SIDE PROFILE OF PILLOW CORE



POLE SURROUNDS

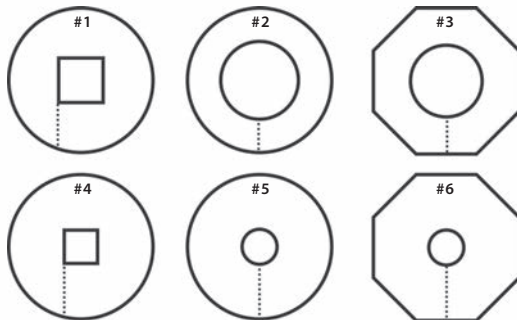

RAIL PADDINGS

SIDE VIEW OF RAIL

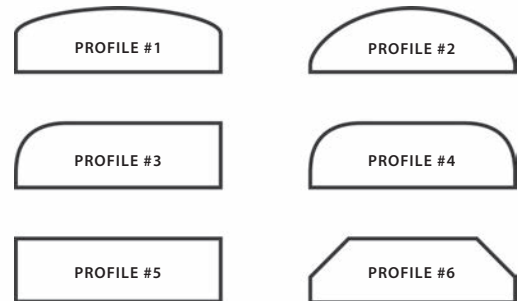

SEAT CUSHIONS *RECESSED*

SIDE VIEW OF CUSHION

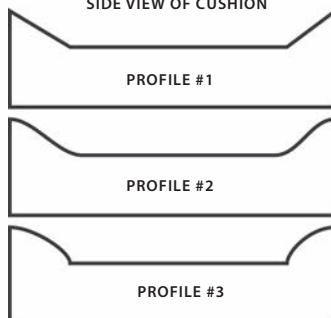

SEAT CUSHIONS *WEDGED*

SIDE VIEW OF CUSHION

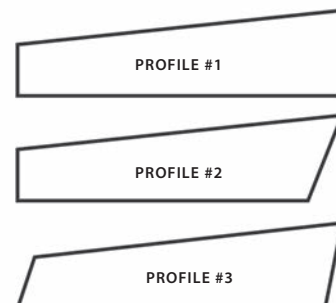

SEATS WITH EDGES CURVED

SIDE PROFILES OF
CUSHION CORES

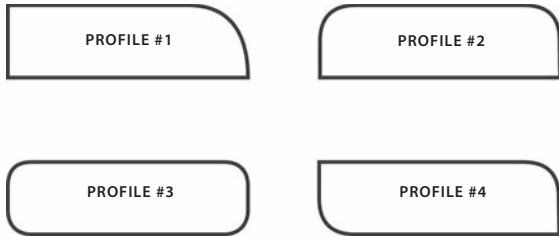

SEATS WITH SIDES TAPERED

SIDE PROFILES OF
CUSHION CORES

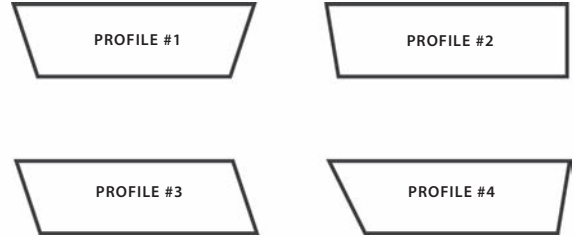

SEAT ROUNDED FRONT EDGE

SIDE PROFILES OF
CUSHION CORES

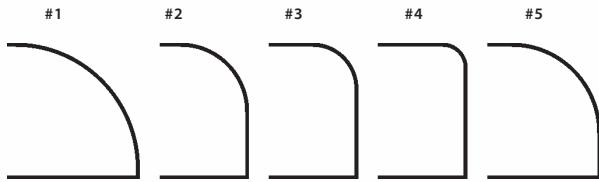

SEAT CUSHIONS BULL NOSED

SIDE PROFILES OF
CUSHION CORES

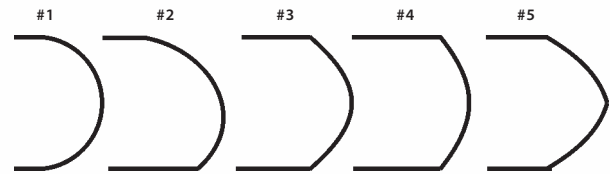

SEATS WITH EDGES BEVELED

SIDE PROFILES OF
CUSHION CORES

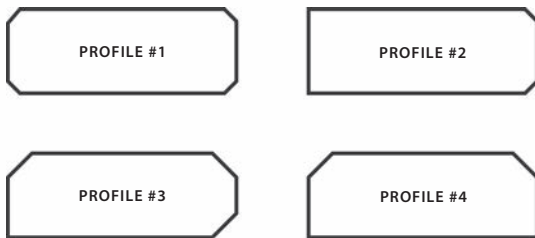

SEAT CUSHION FRONTS

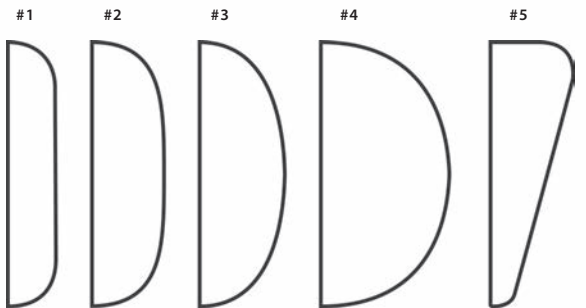

SEATS CUSHIONS WITH "T"

TOP PROFILES OF CUSHION CORES

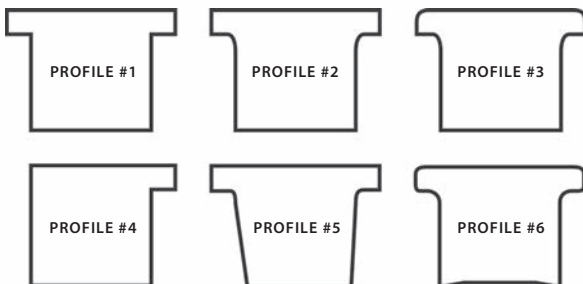

SEATS ROUNDED CORNERS

TOP PROFILES OF CUSHION CORES

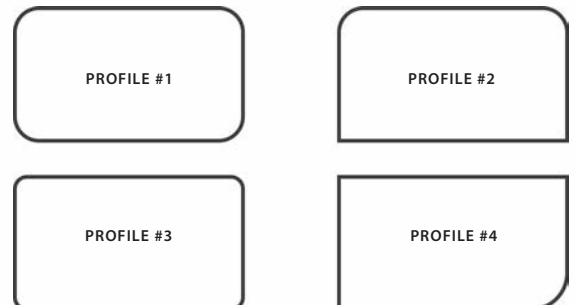

SEATS "D" PATTERNS

TOP PROFILES OF CUSHION CORES

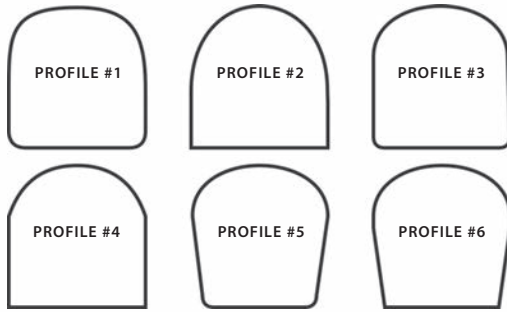

SEATS TRAPEZOID PATTERNS

TOP PROFILES OF CUSHION CORES

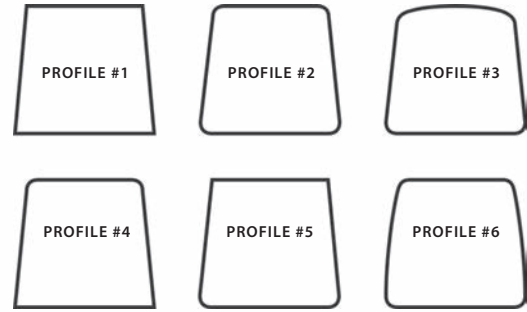

SEAT CUSHIONS CURVED

SIDE PROFILES OF CUSHION CORES

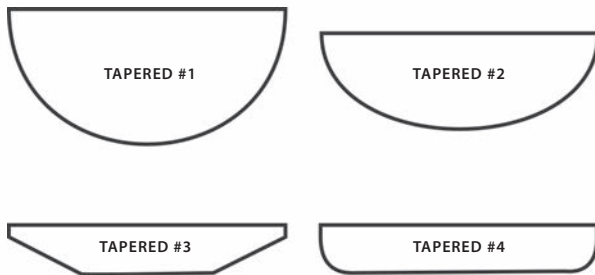

THEATER SEATS

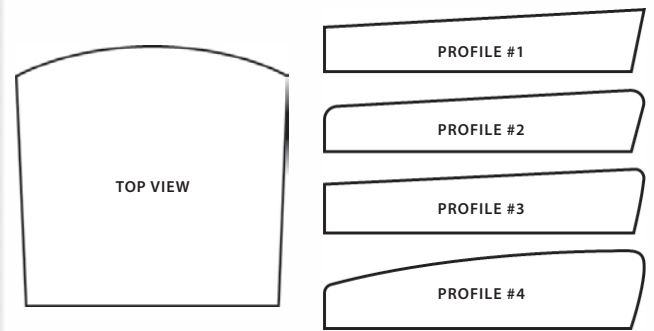

THIGH BOLSTER SUPPORTS

SIDE PROFILES OF CUSHION BERMS

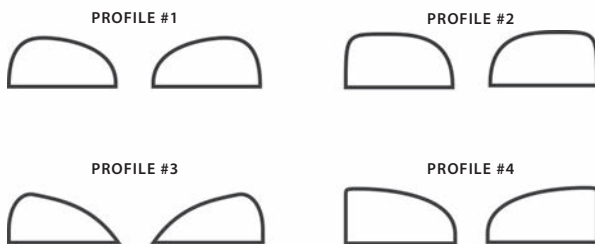

WALL PANELS

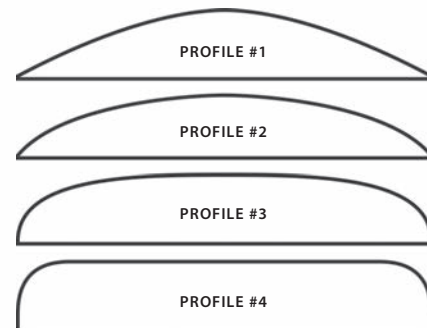

WINDOW SEATS

TOP VIEW

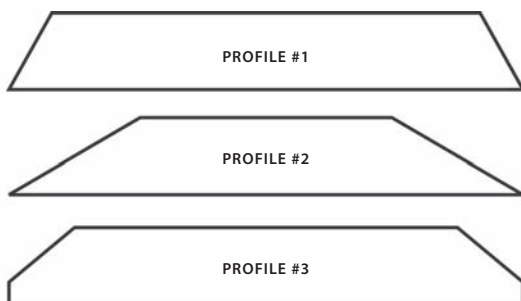

YING YANG SEATS AND BACKS

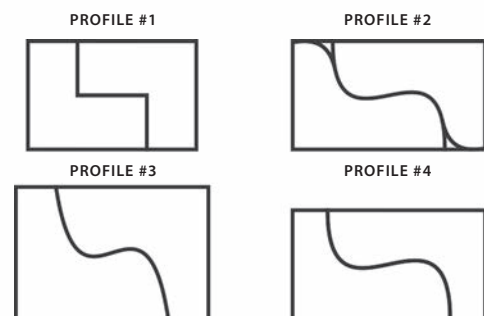

BIOBRED FOAMS

BioBred Foams
are
Hybrid Foams

BIO BRED

A portion of the Polyol is petroleum based.
A portion of the Polyol is soy based.

Eco-Friendly "Green Foam"

Renewable Resources

BioBred Hybrid Foam

Performance Based with BiOH™ Polyols:

- Reduction of density gradients
- Potential lower Fire Retardant additive usage
- Improved UV resistance
- BiOH polyols come from the world's most reliable source for bio-based polyols.
- Foams made with BiOH polyols have a smaller environmental footprint

It's your World, It's your Choice... It's time to Choose... BioBred Hybrid Foams

- Supports the American farmer
- Meets consumers concern for "Green" products
- Lessens dependency on fossil fuels including foreign crude oil
- Provides smaller environmental footprint

Support the American Farmer

- Consumers would rather buy products that are "Made in America"
- Soybeans are currently harvested in a surplus and exported from the United States.
- Backup crops are available from South America in the event of a natural disaster or shortfall

Meets consumers concern for "Green"

- The green market is moving more mainstream...
- Not the traditional environmentalists
- People like you & me who want to feel good about the choices they make.

Consumers want to make responsible choices...

- Buying furniture and bedding that is more earth friendly without sacrificing style and comfort, quality, and without paying a premium.

Lessen dependency on fossil fuels including foreign crude oil

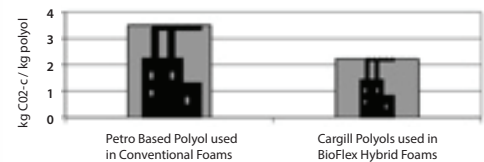

23% reduction in total energy demand
61% reduction in non-renewable energy use
Results based on Preliminary Life Cycle Analysis by Five Winds Intl.

Smaller Environmental Footprint

Petro Based Polyol used in Conventional Foams

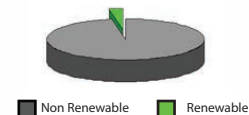

Cargill Polyols used in BioBred Hybrid Foams

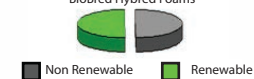

36% less global warming emissions
Results based on Preliminary Life Cycle Analysis by Five Winds Intl.

A Cargill Innovation

Cargill, a \$71 billion company traditionally in the food and agricultural business, has helped innovate the technology of bio-based polyols used in the production of urethane foams. Polyol makes up approximately 60% of the formulation of foam.



The polyols are made through a proprietary process that contains a variety of natural oils, most notably soy.

Cargill is now able to produce enough volumes of the bio-based polyol to support commercial needs and second generation BiOH polyols are already in development.

Performance & Durability Comparison

Based on 1.80 Density Foam

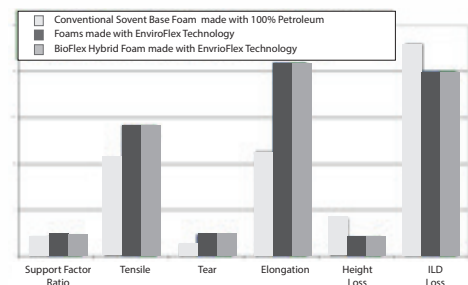

CUSHION WRAP & FIBER GUIDE

BONDED FIBERFILL

RESIN-BONDED, CROSS-LAPPED, SPLITTABLE, GARNETTED BATTING

POLYESTER PRODUCTS	WEIGHT	HEIGHT	WIDTHS	PAGE
Thin-Bond	½ oz	½"	27" 30" 54" 60" 81"	65
Lite-Bond	¾ oz	¾"	27" 30" 54" 60"	65
Mid-Bond	1 oz	1"	27" 30" 54"	65
Heavy-Bond	1¼ oz	1¼"	27" 30" 54" 60"	65

QUILT BOND

LIGHTLY RESIN-BONDED SOFT BLEND, CROSS-LAPPED, SPLITTABLE GARNETTED BATTING

POLYESTER PRODUCTS	WEIGHT/LN YDHEIGHT	HEIGHT	WIDTHS	PAGE
Quilt Bond	6.0 oz (.67/SF)	1"	54" 60"	64

THERMO BOND FIBERFILL

LOW-MELT, SOFT, SLICK BONDED FIBER BATTING

PRODUCTS NAME	WEIGHT	HEIGHT	WIDTHS	PAGE
Smooth-Bond	.65 oz	5/8"	54" 60"	63
Smooth-Bond	1.2 oz	1¼"	30" 54"	64
Smooth-Bond	2.0 oz	2½"	30"	64

DACRON SEWN BACKINGS

SOFT GARNETTED BATTING WITH STITCHED BACKING

PRODUCTS NAME	WEIGHT	HEIGHT	WIDTHS	PAGE
Active-Dac: 1-Side	1.1 oz	1"	30" 36"	62
Active-Dac: 2-Side	1.1 oz	1"	30" 54"	62
DuPont Dac-91: 2 Side	1.5 oz	1½"	30" 40"	62

DACRON PLAIN BATTING

SOFT GARNETTED BATTING WITH ONLY A TISSUE INNERLEAFING

PRODUCTS NAME	WEIGHT	HEIGHT	WIDTHS	PAGE
DuPont Dac-91	2.2 oz	2"	27"	63
Pillow Fill Dac-22	2.2 oz	2"	27"	63

SYNTHETIC DOWN

REVOLUTIONARY TINY FIBER CLUSTERS WHICH FLOW FREELY LIKE DOWN

PRODUCTS NAME	TYPE	FIRMNESS	PAGE
ULTRA-SOFT	Back	X-Soft	66

LOOSE PILLOW FILLS

POLYESTER FIBERS DENSIFIED TO VARYING DEGREES TO ACHIEVE VARIED FIRMNESS

PRODUCTS NAME		PAGE
COMFORT FILL	Loose Fill with Added Resiliency	66
SILK FILL	A Luxurious Polyester Loose Fill	66

DENSIFIED BATTINGS

POLYESTER FIBERS DENSIFIED TO VARYING DEGREES TO ACHIEVE VARIED FIRMNESS

PRODUCTS NAME	WEIGHT	HEIGHT	WIDTHS	PAGE
FIBER CORE	6 OZ	3"	24"	68
FIBER CORE	8 OZ	4"	24"	68
POLYFELT	7/8 OZ	3/16"	54"	67
INSUL-SOFT	¾ OZ	¼"	54"	67
INSUL-SOFT	1 OZ	½"	54"	67
INSUL-FIRM	¾ OZ	¼"	54"	67
FLEX PAD	3.2 OZ	½"	20" 24" 36"	67

WARNING!
POLYESTER FIBER BATTING IS FLAMMABLE. ONCE IGNITED IT BURNS RAPIDLY RELEASING GREAT HEAT AND CONSUMING OXYGEN AT A HIGH RATE. CONSULT WITH YOUR INSURANCE CARRIER TO DETERMINE PROPER HANDLING AND STORAGE MEASURES.

ACTIVE-DAC SEWN FIBERFILL



**A QUALITY DACRON
AT COMPETITIVE PRICES**



SEWN CONSTRUCTION	SEWN BACKING	WEIGHT	WIDTH	LBS/ROLL	YDS/ROLL
1 SIDE	ACCORD	1.1 oz	30"	11	20
1 SIDE	ACCORD	1.1 oz	36"	11	20
2 SIDE	ACCORD / BONTEX	1.1 oz	30"	11	20
2 SIDE	ACCORD / BONTEX	1.1 oz	54"	20	20

BONTEX: An economical non-woven fabric similar to Cushion-eze.
ACCORD: A non-woven fabric that is soft and pliable.

FIRE-RETARDANT: Meets California Technical Bulletin #117

1-SIDED WEIGHT: 1.1OZ THICKNESS: 1"

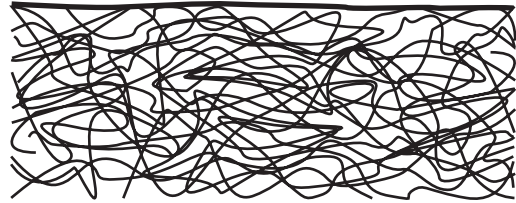

2-SIDED WEIGHT: 1.1OZ THICKNESS: 1"

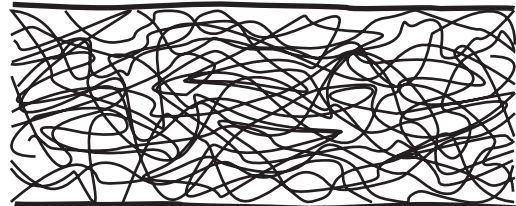

IL AND MI PER LB	ONE SIDED	ROLL	2 ROLLS	4 ROLLS	10 ROLLS
IL AND MI PER LB	TWO SIDED	9.20	8.60	8.30	7.80
WISC PER LB	ONE SIDED	9.40	8.80	8.50	8.00
WISC PER LB	TWO SIDED	9.80	9.20	8.90	8.40
		10.00	9.40	9.10	8.60

DuPONT DAC-91 SEWN FIBERFILL



**THE HIGHEST
QUALITY DACRON**



- DURABLE
- ODORLESS
- RESISTS MATTING
- GENTLY RESILIENT
- EXCEPTIONALLY COMFORTABLE

- PURE
- LINT FREE
- NATURALLY SOFT
- SMOOTH

1-SIDED WEIGHT: 1.1OZ THICKNESS: 1"

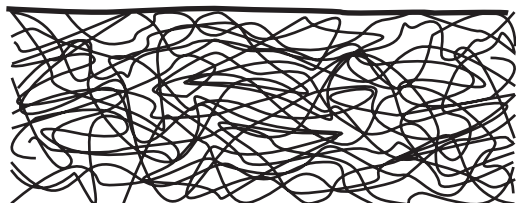

2-SIDED WEIGHT: 1.5OZ THICKNESS: 1½"

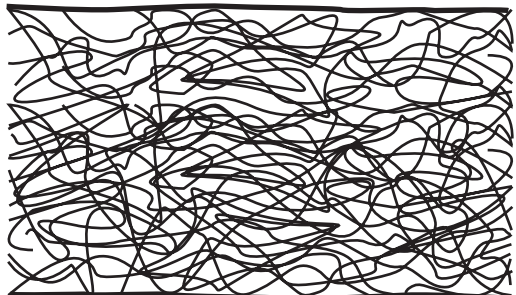

SEWN CONSTRUCTION	SEWN BACKING	WEIGHT	WIDTH	LBS/ROLL	YDS/ROLL
2 SIDE	ACCORD / BONTEX	1.5 oz	30"	14½	18
2 SIDE Ohio Only	ACCORD / BONTEX	1.5 oz	40"	19¼	18

BONTEX: An economical non-woven fabric similar to Cushion-eze.
ACCORD: A non-woven fabric that is soft and pliable.

FIRE-RETARDANT: Meets California Technical Bulletin #117

IL AND MI PER LB:	TWO SIDED	ROLL	2 ROLLS	4 ROLLS	10 ROLLS
WISC PER LB:	TWO SIDED	10.40	10.00	9.60	9.30
		10.60	10.20	9.80	9.50

DuPONT DAC-91 PLAIN HALOFILL



THE HIGHEST
QUALITY DACRON

A LUXURIOUS
DACRON BATTING
UNBONDED

Complies with the Flammability Standards of
California Technical Bulletin #117-2013

WEIGHT: 1.2OZ THICKNESS: 1¼"

SEWN CONSTRUCTION	SEWN BACKING	WEIGHT	WIDTH	LBS/ROLL	YDS/ROLL
PLAIN	NONE	1.2 oz.	27"	10	20

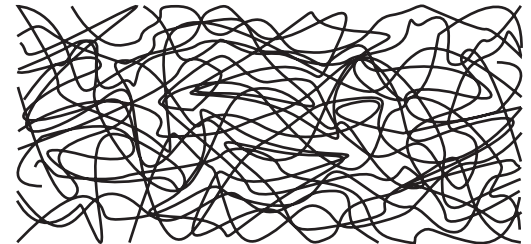

	ROLL	2 ROLLS	4 ROLLS	10 ROLLS
IL and MI PER LB	9.60	9.20	8.80	8.50
WISC PER LB	9.80	9.40	9.00	8.70

PILLOW-FILL DAC II



PREMIUM QUALITY
DACRON PILLOW-FILL

A SUPER-SOFT
2" LUXURIOUS BATTING
UNBONDED

Designed specifically for back pillows and similar constructions. Pillow-Dac II is recommended as a substitute for Quallofil at half the cost.

• DURABLE • HIGH LOFT • DOWN SOFT • RESILIENT

WEIGHT: 2.2OZ THICKNESS: 2"

SEWN CONSTRUCTION	SEWN BACKING	WEIGHT	WIDTH	LBS/ROLL	YDS/ROLL
PLAIN	NONE	2.2 oz.	27"	11 ¾"	12

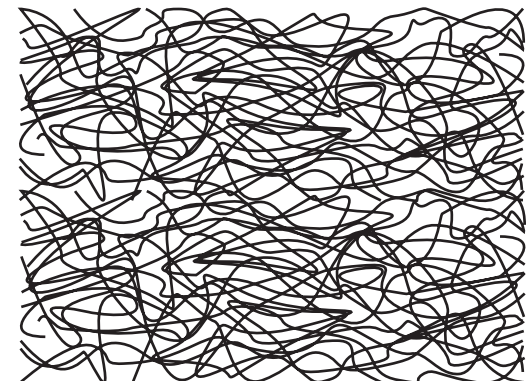

	ROLL	2 ROLLS	4 ROLLS	10 ROLLS
IL and MI PER LB	9.60	9.20	8.80	8.50
WISC PER LB	9.80	9.40	9.00	8.70

SMOOTH-BOND 0.65oz THER BOND-PLUS CUSHION WRAP



ALSO KNOWN AS **QUILT-BOND**

INVALUABLE FOR:

- Cushion wraps • Walls • Quilts

THICKNESS: 3/4"

WIDTHS:	MI 54"	IL 54"	WI 54"	OH 60"
WEIGHT / ROLL	12 3/4	17	17	25
YARDS PER ROLL	30	30	30	40
IL and MI PER LB	ROLL 9.30	2 ROLLS 8.70	4 ROLLS 8.40	10 ROLLS 7.90
WISC PER LB	9.50	8.90	8.60	8.10

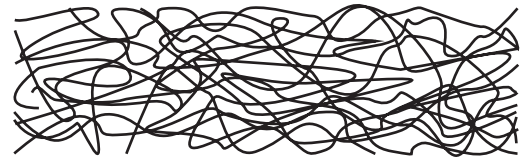

A THIN, SMOOTH, AND SOFT WRAP

SMOOTH-BOND 1.2oz THERMO BOND-PLUS CUSHION WRAP



- VERY SMOOTH • SOFT • RESILIENT
- Able to use with the most delicate of fabrics
- Premium quality cushion wrap
- Fibers are thermally bonded together
- Approx: 18% more fiber per square foot than regular bonded cushion wraps
- Contains no chemical resins to break down or add extra weight
- FIRE-RETARDANT: Meets California Technical Bulletin #117

THICKNESS: 1 1/4"

WIDTHS:	MI 27"	IL/WI 30"	MI/IL/WI 54"	OH 30"/60"
WEIGHT / ROLL	12 3/4	14	25 1/2	14/25
25 YARDS PER ROLL				
IL and MI PER LB	ROLL 9.10	2 ROLLS 8.50	4 ROLLS 8.20	10 ROLLS 7.70
WISC PER LB	9.30	8.70	8.40	7.90

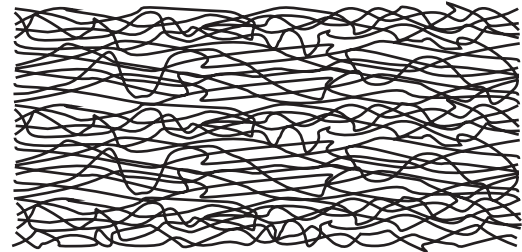

SMOOTH-BOND 2oz THERMO BOND-PLUS CUSHION WRAP



- VERY SMOOTH • SOFT • RESILIENT
- Able to use with the most delicate of fabrics
- Premium quality cushion wrap
- Fibers are thermally bonded together
- Approx: 18% more fiber per square foot than regular bonded cushion wraps
- Contains no chemical resins to break down or add extra weight
- FIRE-RETARDANT: Meets California Technical Bulletin #117

THICKNESS: 2 1/2"

WIDTH: 30"
WEIGHT / ROLL: 17
18 YARDS PER ROLL

IL and MI PER LB	ROLL 9.10	2 ROLLS 8.50	4 ROLLS 8.20	10 ROLLS 7.70
WISC PER LB	9.30	8.70	8.40	7.90

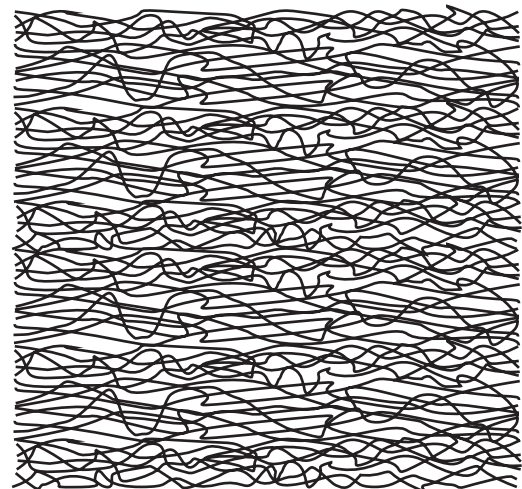

THIN-BOND .5 oz. BONDED FIBERFILL

- Premium quality cushion wrap and general purpose padding
- Saves money due to higher yield
- No need to split thin fill
- FIRE-RETARDANT: Meets California Technical Bulletin #117

MULTI-PURPOSE POLYESTER WRAP:

- CUSHION WRAPPING • WALL COVERING
- INSIDE AND OUTSIDE BACKS • OTHER UTILITY FUNCTIONS

LOCATION:	MI	IL/WI	WI	OH
WIDTHS:	27"/54"	30"/54"	81"	30"/60"
POUNDS / ROLL:	10 / 20	11 / 20	30	9/16
IL AND MI PER LB	ROLL	2 ROLLS	4 ROLLS	10 ROLLS
WISC PER LB	9.30	8.70	8.40	7.90
	9.50	8.90	8.60	8.10



THICKNESS: 1/2"
140 FEET / ROLL

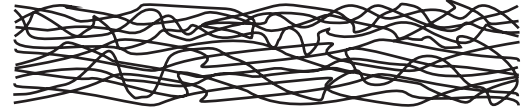

LITE-BOND .75oz. BONDED FIBERFILL

- Premium quality cushion wrap and general purpose padding
- Constructed of lightly bonded, high quality garnetted fibers
- FIRE-RETARDANT: Meets California Technical Bulletin #117
- SPLITTABLE scissor-patterned fiber creating a soft and ultra smooth surface
- Fibers run in a scissor pattern making the surface feel soft and ultra smooth
- Lite and Mid-Bond are the most popular bonded fiberfill weights for cushion wraps

MULTI-PURPOSE POLYESTER WRAP:

- CUSHION WRAPPING • PLUSH WALL COVERING • PLUSH PADDINGS

LOCATION:	MI	IL	WI	OH
WIDTHS:	27"/54"	30"/54"	30"/54"	30"/60"
POUNDS / ROLL	10/20	12/20	12/20	12/22
IL AND MI PER LB	ROLL	2 ROLLS	4 ROLLS	10 ROLLS
WISC PER LB	9.30	8.70	8.40	7.90
	9.50	8.90	8.60	8.10



THICKNESS: 3/4"
90 FEET / ROLL



MID-BOND 1oz. BONDED FIBERFILL

- Premium quality cushion wrap and general purpose padding
- Constructed of lightly bonded, high quality garnetted fibers
- FIRE-RETARDANT: Meets California Technical Bulletin #117
- SPLITTABLE scissor-patterned fiber creating a soft and ultra smooth surface
- Fibers run in a scissor pattern making the surface feel soft and ultra smooth
- Lite and Mid-Bond are the most popular bonded fiberfill weights for cushion wraps

MULTI-PURPOSE POLYESTER WRAP:

- CUSHION WRAPPING • WALL COVERING
- INSIDE AND OUTSIDE BACKS • OTHER UTILITY FUNCTIONS

LOCATION:	MI	IL/WI	ALL
WIDTHS:	27"	30"	54"
POUNDS / ROLL	10	12	20
IL AND MI PER LB	ROLL	2 ROLLS	4 ROLLS
WISC PER LB	9.30	8.70	8.40
	9.50	8.90	8.60
			10 ROLLS
			7.90
			8.10



THICKNESS: 1"
70 FEET / ROLL

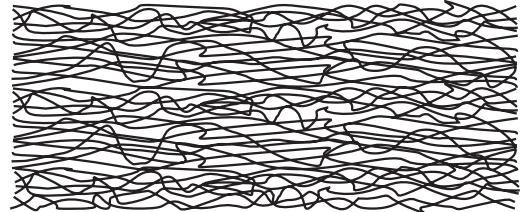

HEAVY-BOND 1.2 oz. BONDED FIBERFILL

- Popular weight among furniture manufacturers
- Premium quality cushion wrap and general purpose padding
- Made from high quality garnetted fibers that are lightly bonded
- Fibers run in a scissor pattern giving a soft and ultra smooth surface
- SPLITTABLE TYPE allowing for thinner thicknesses
- For thicker over-stuffed cushions
- FIRE-RETARDANT: Meets California Technical Bulletin #117

LOCATION:	MI	IL/	WI	OH
WIDTHS:	27"/54"	30"/54"	30"/54"	30"/60"
POUNDS/ROLL	10/20	11/20	11/20	15/26
IL AND MI PER LB	ROLL	2 ROLLS	4 ROLLS	10 ROLLS
WISC PER LB	9.30	8.70	8.40	7.90
	9.50	8.90	8.60	8.10



THICKNESS: 1 1/4" 60 FEET / ROLL

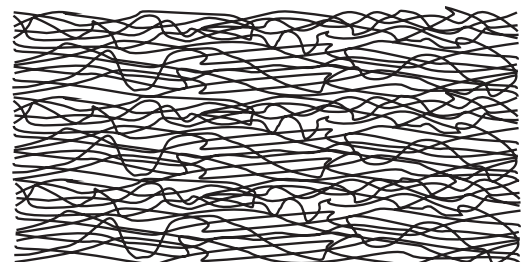

ULTRA-SOFT *SYNTHETIC DOWN*

*SINK INTO LUXURIOUS COMFORT
AT AN EXTRAORDINARY PRICE*

Ultra-Soft synthetic down is a fiber cluster for back cushions & pillows that provides the luxurious **comfort of down** with greater loft and durability at approximately **half the cost**.

Non-allergenic Ultra-Soft is a special blend of medium and heavy denier fibers which provides the right amount of softness for backs and pillows so that cushions have exceptional, re-fluffable, down-like comfort.

- ULTRA-SOFT is made from 100% Dacron polyester and has no odor nor proteins to support micro-organisms that cause allergies.
- ULTRA-SOFT is manufactured to specifications that ensure consistency for every run, unlike natural fill blends that also vary in cleanliness and content.
- ULTRA-SOFT provides luxurious comfort, durability and ease of care.

ONLY 1.6 LBS TO FILL A
22" X 22" PILLOW FORM
(Approximate)

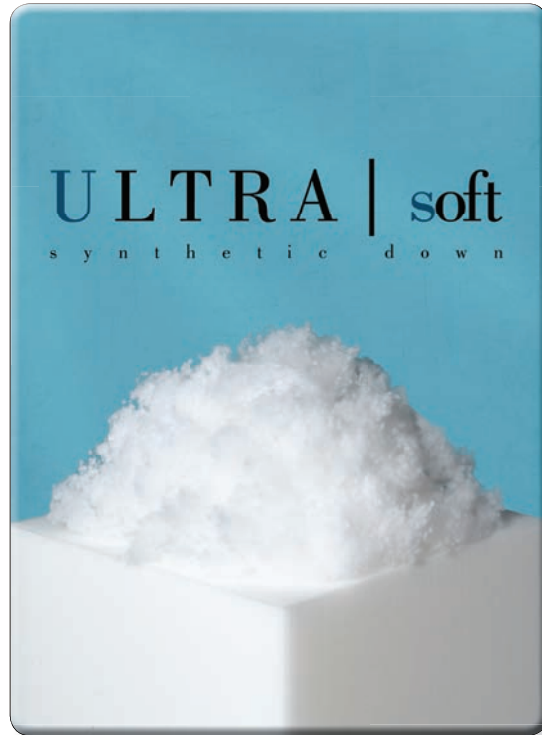

*ULTRA-SOFT PROVIDES A GREATER
PERCENTAGE OF LOFT PER OUNCE*

ULTRA-SOFT	PER LB	10 LB	25 LB	130 LB
	14.00	13.70	11.30	9.70

SILK FILL

*DELUXE SUPER-SOFT
POLYESTER LOOSE FILL
FOR PILLOWS*



PER POUND	5 LB	25 LB	50 LBS	100 LBS
UPS BOX	10.70	8.70	8.30	8.10
	6.00	<i>Must be boxed to avoid UPS Surcharges</i>		

COMFORT FILL

*TOP QUALITY
SOFT RESILENT LOOSE FILL
FOR PILLOW STUFFING
AND MORE!*



PER POUND	5 LB	25 LB	50 LBS	100 LBS
UPS BOX	10.20	8.20	7.80	7.60
	6.00	<i>Must be boxed to avoid UPS Surcharges</i>		

POLYFELT

POLY FELT is a 7/8oz NON resinated needle punched polyester batting.
POLY FELT is a thin uniform pad used for arms & outside backs.
POLY FELT gives you a fine tailored & clean look.
POLY FELT can easily be cut for bindings and edging .
POLY FELT has a thin fabric needle punched between the fibers giving it stability and strength.



3/16" X 54" X PER FOOT	50FT ROLL 2.58 (129.00)	150FT ROLL 2.30 (345.00)	3/150FT ROLLS 2.10 (315.00)
-------------------------------	-----------------------------------	------------------------------------	---------------------------------------

INSUL-SOFT

- Lightly resinated DENSIFIED polyester batting
- Made of SOFT fibers so thin fabrics may be used
- A uniform pad used for arms and outside backs
- Displays a fine tailored and clean look
- Cuts easily for bindings and edging
- Good strength in one direction



1/2" X 54" X 60'	OZ/SF 1.00	ROLL 118.00	2 ROLLS 110.50	4 ROLLS 105.00
1/4" X 54" X 60'	0.50	96.00	90.00	86.00

INSUL-FIRM

THIN and FIRM
INSULATOR PAD

- 1/4" uniform padding
- Outside backs and arms
- Holds a staple
- Easy to cut
- Good strength
- Uniform thickness



1/4" X 30"	OZ/SF 0.875	1 50 FT ROLL 69.00	1 150 FT ROLL 174.00	3 150 FT ROLL 162.00
-------------------	-----------------------	--	--	--

FLEX PAD

DURABLE and FLEXIBLE PADDING

ROLL WIDTHS: 20 inches and 24 inches
ROLL LENGTHS: 35 ft and 105 ft

- Dual density pad
- Meets UFAC
- Heavy 3.2 oz. /sq ft

FLEX PAD is designed to be used over platform spring construction. It does not require other insulation materials. Extremely durable and easy to apply directly over spring base and attach cover. The bottom side of pad is a firm and flexible consistency. The top is soft and springy; will not set, and is noiseless. It replaces multi-material construction. Meets Cal. 117 and UFAC.



1/2" X 20"	FOOT 4.30	35 FT ROLLS 70.70	105 FT ROLLS 163.80	3 / 105 FT ROLLS 149.10
1/2" X 24"	4.70	79.10	186.90	170.10
1/2" X 36"	6.50	118.30	277.20	256.20

FIBER CORE

- Densified polyester batting designed to be used as a seat cushion core instead of using foam cores.
- The 4" densified batting provides a medium-soft feel and dries quickly
- Best to cut with an electric foam cutter.
- Complies with California Technical Bulletin #117

APPLICATIONS:

- Lawn and Porch Furniture
- Boat and Marine Cushions

Weight Per Square Foot: 2"=6oz, 4"=8oz.

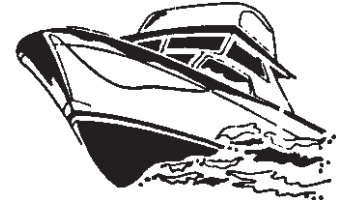
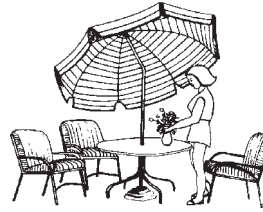

	TYPE	1 SHEET	4 SHEETS	8 SHEETS	16 SHEETS
2" X 24" X 79"	FIRM	53.90	49.90	46.90	43.90
4" X 24" X 79"	MEDIUM	71.90	67.90	63.90	59.90

CUSTOM FIBERFILLS, DACRONS & FUTONS

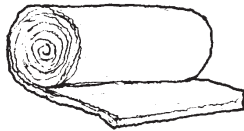

RESIN-BONDED
FIBERFILLS

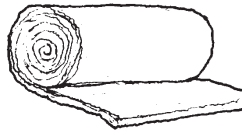

THERMO-BOND
FIBERFILLS

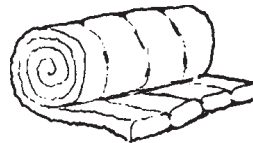

SEWN DACRON
CUSHION WRAPS



POLYESTER FUTON
FIBER CORES

**MINIMUM ORDERS DEPENDING ON THE ITEM and REQUIREMENTS: 500 - 750 POUNDS
PLEASE CALL FOR INFORMATION AND PRICING ON SPECIFIC ITEMS**

CUSTOM FABRICATED FIBER PARTS

TAKE ADVANTAGE
OF OUR FABRICATORS
AND SAVE MONEY!

- 1) CHOOSE FIBER TYPE
- 2) SPECIFY SIZE AND / OR PATTERN
- 3) WE CUT!

FIBER TYPE	WEIGHT OZ.	THICKNESS
THIN-BOND	0.50	1/2"
LITE-BOND	0.75	1"
MID-BOND	1.00	1 1/4"
HEAVY-BOND	1.25	1 1/2"
SMOOTH-BOND	0.65	5/8"
SMOOTH-BOND	1.20	1 1/4"
SMOOTH-BOND	2.00	2 1/2"
SMOOTH-BOND	3.00	4"
FIBER CORE	6.00	3"
FIBER CORE	8.00	4"
POLYFELT	1.00	1/2"
INSUL-SOFT	0.50	1/4"
INSUL-SOFT	1.00	1/2"
INSUL-FIRM	0.75	1/4"
FLEX PAD	3.20	1/2"

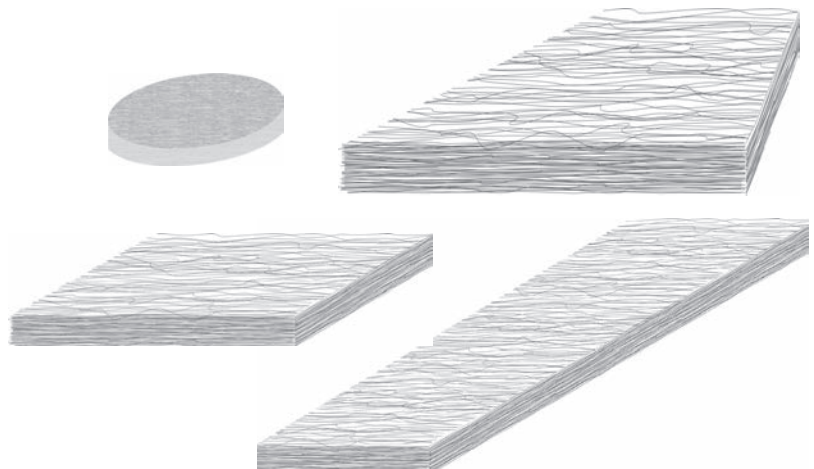

ROYAL COTTON BATTING

GRADE	NUMBER	WIDTH	WISCONSIN WEIGHTS	ILLINOIS WEIGHTS	MICHIGAN WEIGHTS	OHIO WEIGHTS
ROYAL	#185	27"	18, 24	12, 18, 24	12, 18, 24	12, 18
<i>For Wisconsin stock: Please add a \$.18 destination freight charge.</i>						
PER POUND		ROLL	2 ROLLS	BALE	2 BALES	
		4.88	4.16	3.96	3.88	



SUPREME COTTON BATTING

GRADE	NUMBER	WIDTH	WISCONSIN WEIGHTS	ILLINOIS WEIGHTS	MICHIGAN WEIGHTS	OHIO WEIGHTS
SUPREME	#150	27"	18	12, 18, 24	12, 18, 24	12, 18
<i>For Wisconsin stock: Please add a \$.14 destination freight charge.</i>						
PER POUND		ROLL	2 ROLLS	BALE	2 BALES	
		4.40	3.68	3.48	3.40	



CUSHION COTTON BATTING

GRADE	NUMBER	WIDTH	WISCONSIN WEIGHTS	ILLINOIS WEIGHTS	MICHIGAN WEIGHTS	OHIO WEIGHTS
CUSHION	#200	27"	18	12, 18, 24	12, 18, 24	12, 18
<i>For Wisconsin stock: Please add a \$.18 destination freight charge.</i>						
PER POUND		ROLL	2 ROLLS	BALE	2 BALES	
		4.08	3.36	3.16	3.08	



POLY SUPREME COTTON BATTING

GRADE	NUMBER	WIDTH	WISCONSIN WEIGHTS	ILLINOIS WEIGHTS	MICHIGAN WEIGHTS	OHIO WEIGHTS
WHITE	#155	27"	18	12, 18, 24	12, 18, 24	12, 18
<i>For Wisconsin stock: Please add a \$.18 destination freight charge.</i>						
PER POUND		ROLL	2 ROLLS	BALE	2 BALES	
		5.34	4.62	4.42	4.34	



SPECIAL SERVICES COTTON BATTING

Cotton batting may be special ordered to your specifications: grade, weight (thickness), and width. The minimum order is 3 bales, which is approximately 480-500 lbs. If you require substantially narrower widths such as 20" for booth work, special ordering can save you 26%. Lead time is 5 to 10 working days.

COTTON BATTING: Put-ups and Shipping

SINGLE ROLLS: Approximately 20 pounds of cotton paper-wrapped batting with a narrow paper separator

PONY BALES: 2 rolls paper-wrapped together that can be shipped UPS; approximately 40 pounds total weight

BALES: 8 rolls approximate weight of 160 pounds

Weights are per yard, and thickness will vary depending upon the quality of the cotton.

18 oz. cotton is approximately 1" thick.

APPROXIMATE YARDS PER ROLL:

12 oz = 27 YDS

18 oz = 18 YDS

24 oz = 13½ YDS

NO. 69 BONDED NYLON THREAD 10 oz

#69 Bonded nylon is popular due to numerous advantages over other threads. It has very high tensile strength and great resistance to abrasion. This nylon thread is also resistant to sunlight and mildewing. The colors tend to be more true and more vibrant than cotton, enabling better matches.

BASICS

8678 Black
8410 Egg Shell
8402 Snow White
8406 White

REDS

8606 Pink
8442 Cherry
8454 New Berry
8458 Raspberry
8438 Red
8450 Russet
8434 Scarlet
8446 Wine

GREYS

8674 Dark Grey
8662 Grey
8654 Light Grey
8646 Mushroom
8650 Nickel
8658 Pewter
8670 Smoke
8666 Steel

72 COLORS

**ACTUAL THREAD
SAMPLED ON
CHARTS**

YELLOW & ORANGE

8618 Burnt Orange
8418 Nectar
8426 Orange
8422 Tangerine
8430 Toboggan
8414 Yellow

GREENS

8542 Beaver
8526 Emerald
8534 Evergreen
8518 Green
8514 Holly
8522 Hunter
8530 Leaf
8510 Lime
8502 Misty
8506 Turquoise

BEIGES & TANS

8558 Ash
8626 Bamboo
8562 Beige
8586 Caramel
8624 Ecru
8538 Hemp
8578 Light Tan
8582 Natural
8484 Tan
8590 Wicker

- 8 OZ SPOOLS
- 3,000 YDS / SPOOL
- 6,000 YDS / LB
- TENSILE: 11 LBS
- 3 PLY BONDED
- GOV. SIZE E

BROWNS

8610 Amber
8630 Brown
8642 Dark Brown
8638 Dk Mahogany
8570 Dark Sand
8634 Espresso
8594 Gold Brown
8574 Latte
8598 Light Brown
8622 Rust
8566 Sand
8550 Seal
8614 Sienna
8554 Taupe
8602 Toast
8546 Willow

BLUES

8482 Blue
8470 Blue Grey
8486 Cadet
8478 Light Blue
8498 Midnight
8494 Navy
8462 Orchid
8466 Purple
8474 Slate
8490 Yale Blue



ALL COLORS

PER SPOOL

SPOOL
35.80

4 SPOOLS
32.70

8 SPOOLS
31.90

COLOR CHARTS
15.00

NO. 69 BONDED NYLON THREAD 1 LB TUBE

- 16 OZ
- SPOOLS
- 6000 YDS / LB
- TENSILE: 11 LB
- 3 PLY BONDED
- GOV. SIZE E

COLORS
721 WHITE
751 BEIGE
744 BLACK



PER SPOOL

SPOOL
61.20

4 SPOOLS
59.20

8 SPOOLS
57.20

NO. 69 BONDED NYLON "G" BOBBINS

BASICS

8678 BLACK
8406 WHITE
8582 NATURAL
8558 ASH

BROWNS

8554 TAUPE
8562 BEIGE
8598 LIGHT BROWN
8630 BROWN

BLUES

8494 NAVY

GREYS

8650 NICKLE
8662 GRAY
8674 DARK GRAY

REDS

8438 RED

• 31 YARDS / BOBBIN



1/2 GROSS BOXES

1/2 GROSS
58.50

2 GROSS
56.50

NO. 69 BONDED NYLON "M" BOBBINS

• 52 YARDS / BOBBIN

COLORS
WHITE
BLACK
BEIGE
BROWN



1/2 GROSS BOXES

1/2 GROSS
82.40

2 GROSS
78.40

NO. 69 BONDED NYLON "A" BOBBINS

• 52 YARDS / BOBBIN

SPECIAL ORDER

COLORS
721 WHITE
744 BLACK
745 BEAVER



1/2 GROSS BOXES

1/2 GROSS
85.20

2 GROSS
81.20

THREAD CHART No. 69 BONDED NYLON

LARGE
72 COLORS
SELECTION CHART
of actual thread sampled

THE COLOR CHART
WHICH MAKES COLOR
MATCHING EASIER!

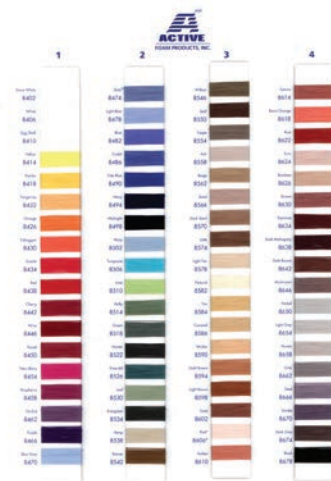

EACH CHART

15.00

SPECIAL ORDERS



Do you have a special application
and need
a thread you don't
see here?

As you know, having
the right thread will
make your job easier.
So give us a call
and let us help!

No.92 AMANN POLYESTER THREAD

An absolute must for outdoor use. Unlike nylon, polyester will hold up to direct sunlight.

- HIGH PERFORMANCE BONDED THREAD
- RESISTANT TO ULTRA VIOLET RAYS
- RESISTANT TO UNTWISTING
- 80Z: ALL COLORS 16OZ SPOOLS: MARKED WITH *



SERABOND UVR



CHICAGO MELWAUER EASTPOINTE NORTH LIMA
10000 N. WILSON ST. CHICAGO, IL 60642 TEL: 773.550.1900
10000 N. WILSON ST. MELWAUER, OHIO 43041 TEL: 614.885.1900
10000 N. WILSON ST. EASTPOINTE, OHIO 44021 TEL: 440.327.1900
10000 N. WILSON ST. NORTH LIMA, OHIO 44851 TEL: 440.337.1900

PHOTOGRAPHIC COLOR
SAMPLING CHARTS AVAILABLE

BASICS

201 NATURAL WHITE*
202 CREME
203 SAND
224 BLACK*

GREENS

219 SEAGRASS
220 FOREST
228 DARK OLIVE

YELLOWS

239 OCHRE
212 SUNFLOWER

BLUES

213 ROYAL BLUE
214 PACIFIC BLUE
216 NAVY
225 MEDITERANEAN BLUE

GREYS

221 PEARL GREY
222 SHARK GREY
223 CHARCOAL
234 MEDIUM STEEL
236 GRAPHITE

REDS

206 TOBAGGAN
207 RED
208 BURGUNDY
209 BLACK CHERRY

BROWNS

204 BROWN
205 BAY BROWN
229 BEAVER
231 SADDLE
238 SANDSTONE
252 NUTMEG

80Z SPOOLS
16OZ SPOOLS

SPOOL
36.90
61.20

4 SPOOLS
33.80
59.20

8 SPOOLS
33.00
57.20

CLEARON MONOFILAMENT MODERN MONO

TRANSPARENT MONOFILAMENT SEWING THREAD

- WEIGHTS: #52 MEDIUM 8600 YDS / LB
#63 HEAVY 7100 YDS / LB
- 1.5LB CANISTERS (approx)

Ideal for sewing in blindstitch operations and for quilting on soft home products. Also used for specialty industrial applications where thread stiffness and stich removal are required.

- 100% Nylon Monofilament with Soft Finish
- Translucent, blends with many colors
- Minimizes thread changes and machine adjustments
- Sews well on blindstitch machines
- Fiber Resistance to Acid Good
- Fiber Resistance to Alkali Good
- Fiber Resistance to Bleach and Solvents Good
- Fiber Abrasion Resistance Excellent
- Fiber Resistance to Heat- 142 deg C (Highest continuous temperature before breakdown)



NO. 52 MEDIUM
NO. 63 HEAVY

1 SPOOL
52.10
52.10

4 SPOOLS
49.60
49.60

8 SPOOLS
48.10
48.10

PER POUND
PER POUND

SHAKESPEARE® MONOFILAMENT

Invisible Wonder Thread is a softer monofilament thread which blends with all colors, fabrics, designs and materials. It can be used in combination with other types of threads. Not designed for outdoor use.

- WEIGHTS: #52 MEDIUM 8600 YDS / LB
#63 HEAVY 7100 YDS / LB
- 1.5LB CANISTERS (approx)

- STYLE G-BOBBINS #40 - SIZE: .01
- 50/BOX
- 30 YARDS / BOBBIN



NO. 52 MEDIUM
NO. 63 HEAVY
CANISTERS
BASES
NO. 40 G BOBBINS

1 SPOOL
49.70
47.30
12.20
3.40
55.90

4 SPOOLS
44.30
41.90
10.90
3.00
50.90

8 SPOOLS
42.30
39.90
10.40
2.90

PER POUND
PER POUND

Thread & Cannisters Now Sold Separately.

No.92 SUNGUARD POLYESTER THREAD

An absolute must for outdoor use. Unlike nylon, polyester will hold up to direct sunlight.

- BOAT • AUTO • CANVAS • OUTDOORS
- COLORS TO MATCH SUNBRELLA
- RESISTANT TO ULTRA VIOLET RAYS
- MADE IN THE USA OF DUPONT DACRON
- TENSILE: 14LBS 4 PLY BONDED GOV. SIZE
- 8OZ: ALL COLORS 16OZ SPOOLS: MARKED WITH *
- G BOBBINS: 25 YARDS/BOBBIN

"SUNGUARD"
UVR BONDED POLYESTER THREAD



PHOTOGRAPHIC
COLOR SAMPLING
CHARTS AVAILABLE

BASICS

201Q NATURAL WHITE^{GM1}
202Q OYSTER^{G1}
203Q SAND^{G1}
204Q BEIGE^{GM1}
224Q BLACK^{GM1}

GREENS

217Q DARK TEAL^G
218Q OCEAN GREEN^G
219Q SHAMROCK^G
220Q FOREST GREEN^G
228Q DARK OLIVE

YELLOWS

206Q SUNGLOW
212Q SUNFLOWER

BLUES

213Q BLUE WAVE
214Q PACIFIC BLUE^G
215Q DUSK BLUE^G
216Q NAVY^G
225Q MEDITERANEAN BLUE^G
232Q ADRIATIC BLUE^G
235Q MEDIUM OPAL^G
255Q CONCORD

GREYS

221Q PEARL GREY^{G1}
222Q SHARK GREY^{G1}
223Q CHARCOAL^{G1}
234Q MEDIUM TITANIUM
235Q MEDIUM OPAL^G
236Q GRAPHITE

REDS

207Q CARDINAL^G
208Q BURGUNDY^G
209Q BLACK CHERRY^G
210Q DARK ROSE
211Q DEEP LILAC
226Q PLUM

BROWNS

205Q BAY BROWN^G
227Q TAUPE^G
229Q BEAVER^G
230Q MOCHA^G
231Q SADDLE^{G1}

8OZ SPOOLS
16OZ SPOOLS

SPOOL
56.50
106.60

4 SPOOLS
54.00
103.40

8 SPOOLS
52.00
101.40

"G" PER 1/2 GROSS BOXES
"M" PER 1/2 GROSS BOXES

1/2 GROSS
74.40
92.40

2 GROSS
71.80
88.40

CHARTS
12.00



24/4 KEVLAR MACHINE THREAD

- 6000 Yards / Spool
- 1LB SPOOLS
- MEDIUM WEIGHT
- DECOMPOSITION POINT: 800 F
- NATURAL COLOR: YELLOW

- Kevlar[®] Aramid fiber that provides excellent resistance to high temperature
- Sew interior flame-barriers together to meet stringent flammability codes
- High decomposition temperature and does not melt.



1LB SPOOLS

SPOOL
143.90

4 SPOOLS
137.40

#18 BONDED NYLON HANDSEWING THREAD

• 251 YDS / SPOOL

• 2008 YDS/LB

BASICS

744 BLACK
721 WHITE
722 NATURAL
751 BEIGE

GREYS

747 CUB

BLUES

765 NAVY

REDS

757 RED
766 CHERRY
774 ROSEATE
780 RUST
784 LAVENDER

YELLOWS

752 GOLD
765 LEMON

GREENS

770 SAGE
779 DARK GREEN

BROWNS

763 LT BROWN
756 BROWN
745 BEAVER
767 CARAMEL



2 OZ. SPOOLS

SPOOL
13.90

4 SPOOLS
12.90

8 SPOOLS
11.90

NO. 46 BONDED NYLON THREAD

- 1LB SPOOLS
- 9,800 YDS/SPL
- Tensile: 8 lbs
- 2 Ply Bonded
- Gov. Size B

COLORS
721 WHITE
744 BLACK



1 LB SPOOLS

SPOOL
86.40

4 SPOOLS
82.40

NO. 138 POLYESTER THREAD

USES:

- AWNINGS
- TENTS
- INDUSTRIAL

- 3000 YDS / LB
- TENSILE: 21 LBS
- 3 PLY BONDED

- RECOMMENDED NEEDLE:
#150 - SINGER 24
- GOV. SIZE: FF

COLORS
BLACK
WHITE



1 LB SPOOLS
"G" BOBBINS ½ GROSS BXS

SPOOL
104.40
92.20

4 SPOOLS
100.40

QTC "CONTRAST" T270 Bonded Nylon

- 701Q Natural
- 702Q King Blue
- 703Q Toboggan
- 704Q Tan
- 706Q Dark Grey
- 707Q Scarlet
- 709Q Forsythia
- 710Q Dark Pink
- 712Q Oregon Purple
- 714Q Chinese Rust
- 715Q Cathay Blue
- 716Q Hunter
- 717Q Saddle
- 718Q Lime
- 719Q Scarab
- 720Q Nickel
- 721Q White
- 744Q Black

QTC "Contrast" is perfect for decorative seat trimming, accent stitching and much more.

This thread will create a bold effect in any seam that is guaranteed to get noticed.

- QTC Contrast Thread is a 100% bonded nylon thread, size T270.
- Colors are securely dyed. There is no risk of migration.
- Dyestuffs that are used with nylon thread are not recommended for UV exposure due to the risk of rapid fading.
- Nylon thread inherently has excellent abrasion characteristics.

Frequently asked questions

Why isn't QTC Contrast Thread in polyester?

Some polyester threads are made with dyes that can migrate into vinyl and leather.

What is migration?

Migration is a chemical reaction between the types of dyes used in the thread and certain vinyl and leather.

Note: Although the thread and vinyl are manufactured correctly, the dye transfer may still occur.

*Any dyed polyester product should be thoroughly tested for color migration using an appropriate dye migration test.

Is there any way to fix a color transfer?

Once the migration of color occurs, it is permanent. It cannot be cleaned or repaired.

Just a reminder about contrast stitching

When using polyester thread, only a solution-dyed product inherently has no dye transfer or color migration risk.

Size	T-270
Yards per spool (8 oz)	800
Break Strength	49 lbs
Plies	3
Government Size	4/C
% Elongation	22
Recommended Needle Size	24-26



8 OZ SPOOLS

SPOOL
55.80

4 SPOOLS
52.80

8 SPOOLS
50.80

LUDLOW NYLON BUTTON TUFTING TWINE

- PREMIER HARD-BONDED BUTTON TWINE • RESISTS CHAFING • KNOT RETENTION
- 700 YARDS PER POUND



8 OZ BOX	1 BOX 21.90	6 BOXES 19.70	
2 LB TUBE	TUBE 71.50	2 TUBES 69.30	4 TUBES 67.10

RUBY ITALIAN SPRING TWINE

- NO. 1400 6 PLY HEMP TWINE
- 250 FT/LB.
- CAN BE SUBSTITUTED FOR 3/32 WELT



Buy Only
"Ruby" Brand
Hemp Twine



1 LB. BALLS	BALL 27.30	6 BALLS 26.30
5 LB. BALLS	BALL 127.70	6 BALLS 123.20
50 LB. REEL	REEL 973.10	
50 LB. REEL (many ends)	REEL 973.10	
	2 BALLS 125.70	



LUDLOW'S #6 POLYESTER SPRING TWINE

- 33% STRONGER • HOLDS KNOTS MORE SECURELY
- COSTS LESS PER YARD • SUPERIOR RESISTANCE TO CHAFING
- USED BY MAJOR FURNITURE MANUFACTURERS
- 100 % TREATED POLYESTER
- TENSILE STRENGTH - APPROX. 450 LBS.
- 366 FT / LB
- MANY ENDS: 50 STRANDS



1 LB BALLS	BALL 28.50	6 BALLS 26.20
5 LB BALLS	116.10	108.70
10 LB BALLS	243.70	229.10
50LB BALLS (Many Ends)	999.70	-

#4.5 NYLON COIL ZIPPER

- 100 YARD ROLLS
- 1/2" WIDE TAPE
- BREAK STRENGTH: 220 lbs
- SLIDES / PULLS
- NOTCH LOCK
- 100 PER BAG

#4.5 PER ROLL	1 ROLL 72.60	2 ROLLS 68.60	4 ROLLS 62.60
#4.5 SHORT PULLS	BAG 15.90	4 BAGS 13.90	

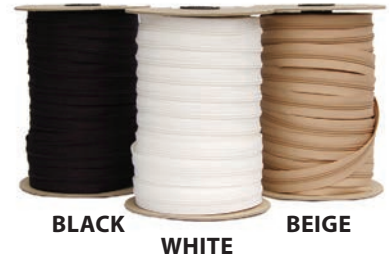

#5 NYLON COIL ZIPPER

- 100 YARD ROLLS
- 5/8" WIDE TAPE
- BREAK STRENGTH: 220 lbs
- SLIDES / PULLS
- NOTCH LOCK
- 100 PER BAG

#5.0 PER ROLL	1 ROLL 78.20	2 ROLLS 74.20	4 ROLLS 68.20
#5.0 SHORT PULLS	BAG 17.90	4 BAGS 15.90	

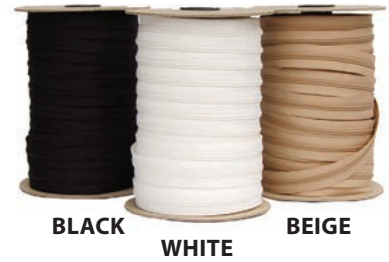

#5 ALUMINUM ZIPPERS

- 100 YARD ROLLS
- 9/16" WIDE TAPE
- BREAK STRENGTH: 150 lbs
- SLIDES / PULLS
- NOTCH LOCK
- 100 PER BAG

WHITE, BEIGE or BLACK	1 ROLL 151.70	2 ROLLS 145.70	4 ROLLS 139.70
100 PULLS	BAG 27.40	4 BAGS 25.90	
100 STOPS: TOP	12.70	11.20	
100 STOPS: BOTTOM	10.80	9.30	

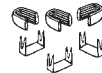
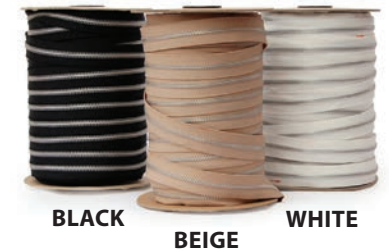

CUT LENGTH ZIPPERS

#2.5 NYLON 9/16" BEIGE TAPE OPEN TOP ONLY



SIZE	LENGTH	EACH	DOZ
#2.5	18"	1.90	1.50
#2.5	24"	2.10	1.70
#2.5	30"	2.30	1.90
#2.5	36"	2.60	2.20

#3 BRASS 9/16" BEIGE TAPE OPEN TOP ONLY



SIZE	LENGTH	EACH	DOZ
#3	18"	4.90	4.50
#3	24"	5.90	5.50
#3	30"	7.00	6.60
#3	36"	8.10	7.70
#3	72"	15.50	15.10

#5 ALUMINUM 9/16" BEIGE TAPE OPEN TOP ONLY



SIZE	LENGTH	EACH	DOZ
#5	18"	4.90	4.50
#5	24"	5.30	4.90
#5	30"	6.30	5.90
#5	36"	7.40	7.00
#5	72"	14.00	

MARINE AND AWNING ZIPPERS

MORE ZIPPERS ARE IN THE MARINE SECTION PAGE 218.

PIRELLI RUBBER WEBBING

2" Wide x 100 Foot Rolls 20% Elongation

PIRELLI

Why is Pirelli the "only" choice for Rubber Webbing?

- Pirelli Rubber Webbing is unexcelled in Longevity.
- Others can dry out and loose shape in just a few years.
- Generic Brands can also prematurely loose their resiliency & elasticity.
- Generic Brands might save you a few dollars, but at what cost?
- 9½ Pounds Per Roll



USE	COLOR	FT/RL	WIDTH	STRETCH	CUTS FOOT	25' ROLL ROLL (FOOT)	50' ROLL ROLL (FOOT)	100' ROLL ROLL (FOOT)
SEATS & BACKS	TAN	100	2"	20%	5.58	114.50 (4.58)	209.00 (4.18)	378.00 (3.78)

INTES ELASTIC WEBBING

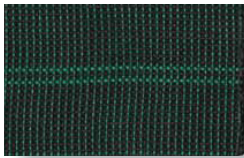

elastbelt®

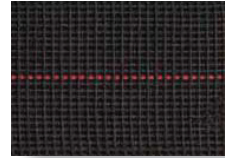

INTES is the largest webbing manufacturer in the world.

We supply webbing to the most prestigious companies in the United States and the world from our headquarters in Italy.

Elasbelt is our brand of latex elasticized webbing. It is made of the finest quality materials and provides a seating suspension system that is superior to any other support system.

Why Webbing? It is less expensive than other suspension systems; requires less production time; eliminates the need for expensive inventories of varying sizes of springs; and leaves almost zero waste. And webbing provides a high quality seating suspension system for every seating application you can imagine.

Made of the highest quality, Elastbelt Is tested and certified for strength, aging and ozone endurance.

It Retains its elasticity after many years of use. Tests show that Elastbelt does not sag or form a permanent set after repeated stretching up to 250,000 times.

- Has polypropylene: Encapsulated latex to ensure long life giving it strength and protection against environmental damage

TYPE	USE	STRIPE/ COLOR	FT/RL	WIDTH	STRETCH	CUTS FOOT	1 ROLL ROLL (FOOT)	4 ROLL ROLL (FOOT)	8 ROLL ROLL (FOOT)
#2	BACKS	2 GREEN/GREEN	164	2"	90%	1.70	72.16 (.44)	62.32 (.38)	55.76 (.34)
#6	SEATS	1 RED/BLACK	164	2"	20%	1.80	91.84 (.56)	82.00 (.50)	75.44 (.46)
#7	SEATS	2 GREY/BLACK	328	3"	5%	1.90	223.04 (.68)	203.36 (.62)	190.24 (.58)

PIRELLI RUBBER WEBBING CLIPS

- 2" WIDE CLIPS

- 55 CLIPS / LB



PER CLIP	EACH	50	100	500
	.52	.42	.32	.24

LUDLOW JUTE WEBBING

- TOP QUALITY
- UNIFORM STRENGTH
- HIGH QUALITY
- TIGHTLY WOVEN
- EVEN SELVEDGES
- 3 1/2" WIDTH X 72 YARD ROLLS



TYPE	STRIPE	WEIGHT	USES
BFM	Black	9 lbs	Seat backs
LMC	Red	11 lbs	Seats

BFM 9 LB.	1 ROLL	6 ROLLS	12 ROLLS	BALE(24)
LMC 11 LB.	59.80	56.80	54.80	50.80
	67.40	64.40	62.40	58.40

SYNTHETIC JUTE WEBBING

THE FINEST WOVEN SYNTHETIC WEBBING

- GREAT FOR DINING ROOM SEATS
- THIN PROFILE • EASY TO TAILOR
- ODORLESS • DUST FREE
- MILDEW RESISTANT • WILL NOT DRY ROT
- HOLDS ITS SHAPE • STRONGER THAN JUTE
- CREATES A STRONG SPRING PLATFORM
- BREAK STRENGTH: 2320 LB TENSILE
- THICKNESS: .047"
- 3 1/2" WIDTH X 100 YARD ROLLS



3 1/2" Width

LIGHT WEIGHT: PER ROLL	USES	1 ROLL	6 ROLLS	10 ROLLS	20 ROLLS
HEAVY WEIGHT: PER ROLL	BACKS	89.50	86.50	83.50	79.50
	SEATS	112.00	109.00	106.00	102.00

SYTEX SUSPENSION FABRIC

Sytex is a seating support system based on unique elastomeric properties of a high strength polyester monofilament. Due to the low elongation requirements of the product, Sytex is simple to apply by hand. However, machines that are specifically designed to apply this material in a safe, efficient manner are available for customers with specific requirements. Sytex has many outstanding features and is manufactured in the United States.

- Sytex is unaffected by fungus, urine, mildew and household cleaners.
- Sytex is easy and safe to apply, and reduces frame stress.
- Sytex is a 100% synthetic product.
- Sytex It exhibits improved heat aging properties & outstanding resistance to ozone.
- Sytex will not sag after years of use. In fact, it will outlast metal spring seats.
- Sytex can be adjusted easily to obtain a firm seat or a deep plush ride.
- Sytex seating support systems surpass the requirements of all government and business technical specifications, including FNE-83 25-B and BIFMA.
- Sytex complies with the flammability requirements of:
 - UFAC - Class 1
 - NFPA 260
 - California TB #117
- Sytex is recommended to be applied with staples with a 1/2" crown, 3 staples per inch at 45 degree angles. Applied Elongation: 12-16%.



TYPE	APPLIED ELONGATION	TYPICAL USE
• Sytex II	12-16%	Medium Seat Average Grade
• Sytex III	3-5%	Extra Firm Institutional Quality

SYTEX II: 20" WIDTH	YARD	10YD	50YD	100YD
SYTEX III: 29 1/2" WIDTH	16.00	14.50	13.00	12.00
	19.60	18.10	16.60	15.60

NEVERSAG STEEL WEBBING

IDEAL SUPPORT FOR UPHOLSTERY

- THICKNESS: .375"
- WIDTH: 1 1/8"
- WEIGHT / ROLL: 8.7 LBS
- Springs slip into place for life
- Staple or nail to frame
- No sewing
- No clipping
- No special fasteners



PER 81' ROLL

1 ROLL
79.20

2 ROLLS
76.20

6 ROLLS
73.70

PASLODE ANCHOR STEEL WEBBING

3/4" WIDE STEEL STRAPPING - HOLES EVERY INCH
100 FT. COIL - Approximately: 4 1/2 LBS
300 FT. COIL - Approximately: 13 1/2 LBS
For steel webbing nails see page 115.



PER COIL

100' COIL
57.20

300' COIL
134.70

2 300' COILS
125.20

4 300' COILS
121.20

COTTON TWILL TAPES

ALL PRICED PER YARD



1/2" WHITE
1/2" BLACK
3/4" NATURAL
3/4" BLACK
1" NATURAL
2" NATURAL

YDS/ROLL
72
72
72
72
100
100

YARD
2.36
2.54
2.56
3.00
2.62
3.10

ROLL
.62
.78
.80
1.24
.82
1.34

4 ROLLS
.46
.60
.62
1.00
.64
1.08

COTTON WEBBING TAPES

FULL ROLLS PUT-UP: 100 YARDS



WIDTH TYPE WEIGHT COLOR
1" I LIGHT NATURAL
1 1/2" I LIGHT NATURAL
2" I LIGHT NATURAL
2" III HEAVY NATURAL

THICKNESS
1/22"
1/22"
1/22"
1/8"

YARD
3.88
4.80
5.70
10.64

100YD
1.88
2.80
3.70
8.64

200YD
1.68
2.60
3.50
8.24

TYPAR REINFORCEMENT SEAM TAPE

WHITE POLYESTER, FULL ROLLS PUT-UP: 125 YARDS

WIDTH
3/4"
1"

PER ROLL
49.00
54.00



FIBER SINGLE WELT CORD

FIRM FIBERFLEX SUPREME

BRAIDED FIBER WELTCORD - BLEACHED, FIRM QUALITY WITH SUPREME CONSISTENCY.
CAN COMBINE FOR QUANTITY DISCOUNT.



SIZE	YD/SPL	SPOOL	4 SPOOLS	8 SPOOLS	10 SPOOLS
3/32	1,000	79.20	77.20	75.20	73.20
4/32	500	44.20	42.20	40.20	38.20
5/32	500	49.40	47.40	45.40	43.40
6/32	500	61.40	59.40	57.40	55.40
7/32	650	90.80	88.80	86.80	84.80
8/32	500	84.40	82.40	80.40	78.40
9/32	450	87.40	85.40	83.40	81.40
10/32	350	79.00	77.00	75.00	73.00
12/32	250	73.20	71.20	69.20	67.20
14/32	200	71.40	69.40	67.40	65.40
16/32	120	55.40	53.40	51.40	49.40



FIBER SINGLE WELT CORD *BOXED*



2,000 YARD CENTER PULL CARTON

SIZE	YD/BOX	BOX	2 BOXES
5/32	2000	177.80	175.80



FIBER DOUBLE WELT CORD



SIZE	YD/SPL	1 SPOOL	4 SPOOLS	8 SPOOLS	10 SPOOLS
4/32	250	70.60	68.60	66.60	64.60
5/32	250	86.00	84.00	82.00	80.00
6/32	135	68.00	66.00	64.00	62.00



COTTON WELTCORD

GREAT FOR QUILTS • COMFORTERS • THROW PILLOWS • WASHABLES



AN ULTRA
SOFT WELTCORD
NATURAL COLOR
10 POUND SPOOLS

SIZE	SIZE	YDS/LB	1 SPOOL	4 SPOOLS	8 SPOOLS
4/32	00	155	209.30	197.50	179.30
5/32	0	120	172.30	162.60	147.60
6/32	1	85	201.80	190.40	172.80
8/32	2	75	175.00	165.10	149.90
10/32	3	60	164.30	155.10	140.70
12/32	4	44	144.50	136.40	123.80
16/32	5	25	139.50	131.60	119.50
22/32	6	10	136.40	128.70	116.80
32/32	7	9	132.40	125.00	113.40
48/32	8	5	149.50	141.10	128.10
64/32	9	4	139.40	131.50	119.40



COTTON DOUBLE WELT CORD

69% Cotton / 31% Polyester

SIZE	SIZE	YDS/SP	1 SPOOL
5/32	0	250	96.60



PLASTIC WELT CORD

A SOFT FOAM PLASTIC WELTCORD

THE FOAM TYPE

NOT THE SOLID ROD TYPE



SIZE	YD/SPL	SPOOL	4 SPOOLS	8 SPOOLS	10 SPOOLS
3/32	500	57.80	55.80	53.80	51.80
4/32	500	60.60	58.60	56.60	54.60
5/32	500	68.40	66.40	64.40	62.40
6/32	500	88.80	86.80	84.80	82.80
7/32	600	160.60	158.60	156.60	154.60
8/32	500	198.80	196.80	194.80	192.80



POLY ROD WELT CORD

A SOLID High Density Plastic Rod

Great for loose cushion backs, auto cushions
and wherever the firmest of welts is needed!

SIZE	YD/SPL	SPOOL	4 SPOOLS	8 SPOOLS
4/32	500	78.40	74.40	70.40
5/32	500	92.20	88.20	84.20



PVC WELT CORD

Great For Marine Applications
Firm, Yet Very Flexible.

SIZE	YD/SPL	SPOOL	YD/SPL	SPOOLS
3/32	100	18.80	1000	147.00
4/32	100	27.70	750	165.40
5/32	100	37.40	500	157.20



WIRE STAKE WELT CORD

16 GAUGE

FIRM WELT FOR LOOSE CUSHIONS • A SUPERIOR AUTOMOTIVE WELT
STABILIZER WIRE FOR SPRING UNITS • KRAFT PAPER WRAPPED

SIZE	LENGTH	EACH	10	25	100	150' COIL	4000' COIL
4/32	54"	3.10	1.40	1.16	.98	46.90	512.50



WELT GUARDS CLEAR

Chair back protector - Designed to be sewn or stapled.



BEADED



STAPLE-ON



PLAIN

PLAIN
BEADED
STAPLE-ON

ACTUAL SIZES

FOOT	50'	250'
4.30	2.72	2.32
3.42	1.72	1.42
3.60	2.02	1.62



BURLAP

100% NEW JUTE BURLAP 40" width 10oz/yd

PER YARD	YARD	25 YD RL	50 YD RL	100 YD RL
	4.20	3.08	2.80	2.60



SAGLESS BURLAP

17.2oz BURLAP 30" Width 100 Yd Pieces (approx.) 100% NEW BURLAP

One layer of Sagless Burlap can replace a woven construction of webbing!

PER YARD	YARD	25 YD RL	50 YD RL	100 YD RL
	10.52	9.28	8.88	8.58



FLW PROPEX *SYNTHETIC BURLAP*

3.0 oz Per Square Yard 40" Width 50 Yd Rls Woven Polypropylene
FLW is a strong woven polypropylene which has a soft facing on one side only.

	WIDTH	YARD	50 YARDS	100 YARDS	200 YARDS
PER YARD	24"	2.70	1.50	1.44	1.28
PER YARD	27"	2.90	1.70	1.62	1.44
PER YARD	36"	3.46	2.26	2.14	1.92
PER YARD	40"	3.70	2.50	2.38	2.14



WP PROPEX *SYNTHETIC WEBBING*

4.4 oz Per Square Yard

Heavy Woven Polypropylene

	WIDTH	YARD	50 YARDS	100 YARDS	250 YARDS
PER YARD	24"	4.02	2.12	2.00	1.82
PER YARD	36"	6.04	3.18	3.00	2.74
PER YARD	48"	8.06	4.24	4.00	3.66



VERSARE *SYNTHETIC BURLAP*

2.3 oz Per Square Yard Point Bonded Spun Polypropylene

Versare is a strong non-woven burlap that is smooth, soft, and very quiet.

	WIDTH	YARD	50 YARDS	100 YARDS	250 YARDS
PER YARD	24"	2.98	1.52	1.40	1.28
PER YARD	40"	3.98	2.52	2.32	2.12



CUSHION EZE

FABRICS EASILY SLIDE ACROSS FOR EASY STUFFING!

A lightweight spun polypropylene synthetic fabric for foiling, cushion wrapping and stuffing problems. Wrap cushions up and slide right in. Can be used for the most economical pillow ticking.

PER ROLL	WIDTH	COLOR	WEIGHT	100 YDS	500 YDS
	40"	WHITE	.5oz	59.10	265.50
	60"	WHITE	.5oz	91.40	412.00



ACCORD (SYNTHETIC CAMBRIC)

THE BEST SYNTHETIC CAMBRIC. A spun polypropylene. SEWABLE, HOLDS STAPLES WELL, and not hairy.

A few possible uses for white Accord • *dust cover for furniture* • *as an economical muslin such as for pillows* • *over foam or dacron like "cushion-eze."*

WEIGHT	COLOR	WIDTH	YDS/RL	1 ROLL	2 ROLLS	4 ROLLS
1.25 oz.	Black	20"	100	46.20	45.20	44.20
1.25 oz.	Black	32"	100	70.80	67.80	66.80
1.25 oz.	Black	36"	100	79.80	77.80	76.80
1.25 oz.	Black	36"	500	322.00		
1.25 oz.	White	36"	100	79.80	77.80	76.80
1.25 oz.	Black	42"	100	113.20	109.20	103.20
1.25 oz.	Black	60"	100	156.20	152.20	146.20
1.25 oz.	White	60"	100	156.20	152.20	146.20
2.00 oz.	Black	36"	100	148.60	142.60	138.60
2.00 oz.	White	36"	100	148.60	142.60	138.60



CRINOL SKIRT LINER

A STIFFENED WOVEN SKIRT STIFFENER.	WIDTH	YDS/RL	1 ROLL	2 ROLLS	4 ROLLS
	5"	100	76.40	74.40	72.40
	6"	100	91.70	89.30	86.90
	7"	100	107.00	104.20	101.40
Firmness: Stiff	8"	100	122.30	119.10	115.90
	10"	100	152.90	148.90	144.90



SKIRT LINING / FILLER *MEDIUM*

A HIGH QUALITY STANDARD SKIRT STIFFENER.	WIDTH	YDS/RL	1 ROLL	2 ROLLS	4 ROLLS
	5"	100	56.00	54.00	52.00
	6"	100	67.20	64.80	62.40
	7"	100	78.40	75.60	72.80
Weight: 5.0 oz	8"	100	89.60	86.40	83.20
	10"	100	112.00	108.00	104.00
	14"	50	78.40	75.60	72.80



SKIRT LINING / FILLER *FIRM*

A HIGH QUALITY THICK, FIRM SKIRT STIFFENER.	WIDTH	YDS/RL	1 ROLL	2 ROLLS	4 ROLLS
	5"	100	56.00	54.00	52.00
	6"	100	67.20	64.80	62.40
	7"	100	78.40	75.60	72.80
Weight: 6.2 oz	8"	100	89.60	86.40	83.20
	10"	100	112.00	108.00	104.00
	14"	50	78.40	75.60	72.80



WOVEN SKIRT LINING / BACKING *8" and 30"*

Weight: 4-5oz

A Medium Weight Woven Skirt backing

	WIDTH	25 YD RL	50 YD RL	100 YD RL
Beige	8"	-	-	1.18
Beige	30"	4.94	4.54	4.04



HEAVY WEIGHT DECKINGS: 30" & 60"

Active Foam believes in quality and as long as we can obtain consistent sources for heavy twills and poplins, we will carry the best. We will stock regular drills only when these premium deckings are not available.

TWILL WEIGHTS: 6oz - 8oz

POPLIN/DUCK WEIGHTS: 6oz - 8oz



Matching up the right decking color will give your job that added smart look giving your customers the added confidence that the job was done right!

	WD	YARD	25 YDS	50 YDS	100 YDS
Beige	30"	5.60	4.70	4.30	3.90
Tan	30"	5.60	4.70	4.30	3.90
Ashes	30"	5.60	4.70	4.30	3.90
Toast	30"	5.60	4.70	4.30	3.90
Taupe	30"	5.90	5.00	4.60	4.20
Cream	30"	5.90	5.00	4.60	4.20
Hunter Green	30"	5.90	5.00	4.60	4.20
Steel Grey	30"	5.90	5.00	4.60	4.20
Dark Grey	30"	5.90	5.00	4.60	4.20
Brown	30"	6.20	5.30	4.90	4.50

	WD	YARD	25 YDS	50 YDS	100 YDS
Blue	30"	6.20	5.30	4.90	4.50
Navy	30"	6.20	5.30	4.90	4.50
Burgundy	30"	6.40	5.50	5.10	4.70
Ivory	30"	6.40	5.50	5.10	4.70
Gold	30"	6.40	5.50	5.10	4.70
Rose	30"	6.40	5.50	5.10	4.70
White	30"	6.40	5.50	5.10	4.70
Black	30"	6.40	5.50	5.10	4.70
Beige	60"	11.70	9.90	9.10	8.30
Black	60"	13.50	11.70	10.90	10.10

MEDIUM WEIGHT DECKINGS: 30"

A medium weight decking with an outstanding value. Weights are normally in the 4-5oz range tending to be mostly drills and ducks.



COLOR	WIDTH	YARD	25 YD RL	50 YD RL	100 YD RL
Beige	30"	5.36	4.32	3.92	3.52
Grey	30"	5.36	4.32	3.92	3.52

FIREGARD®: FLAME BARRIER



FIREGARD®

FIREGARD has had many years of scientific research directed to its development, leading to a family of new textile fabrics. The objective was to develop fabrics that would help contain a fire within the room where it started. Part of the results of the research represents the most significant innovation in the FR marketplace in more than 60 years - the FIREGARD Seating Barriers.

FIREGARD® F170

- Heavy Duty Double Face Knit Barrier Targeted at "Hard To Pass" Fabrics & Design
- Composit Product Consists of: Special Intumescent Fibers Covering A Glass Core.
- The Special Covering Chars to Prevent "Burn-Through" Vapor Phase Helps Extinguish Flames
- Performance is Unaffected by water spills
- Excellent Upholsterability & Breathability

FIREGARD® F117

- Composit Product Consists of: Special Intumescent Fibers Covering A Glass Core.
- The Special Covering Chars to Prevent "Burn-Through" Vapor Phase Helps Extinguish Flames
- Performance is Unaffected by water spills
- Excellent Upholsterability & Breathability

Furniture utilizing FIREGARD Seating Barrier fabric, together with CAL 117 foam and various upholstery fabric, has been shown to pass California Technical Bulletin 133. Variables other than the component products described above can affect whether a piece of furniture passes or fails this test. For this reason, furniture manufacturers are responsible for testing and certifying their furniture with respect to California Technical Bulletin 133.

While the manufacturer views its FIREGARD Seating Barrier fabric as a significant improvement over competitive products, all textile fabrics will burn and generate smoke under certain fire conditions. It is up to the customer to determine if FIREGARD Seating Barrier fabric is suitable for its needs.

Extensive composite testing adhering to California Technical Bulletin 133 has shown outstanding results utilizing FIREGARD Seating Barriers. Acting as a barrier between the flame and internal stuffing, there is no need to use expensive modified foam. FIREGARD Seating Barriers are the best on the market, with qualities surpassing those of competitive barrier products.

FIREGARD Seating Barriers are stretchable and moldable. They may be laminated to upholstery fabric* or glued directly to foam. Priced competitively, these barrier fabrics are also durable to wear and abrasion.

STYLE	WT/SY	WIDTH	YARD	10 YARDS	25 YARDS	50 YARDS
F117	5.50	60"	34.80	30.80	28.80	26.80
F170	7.00	60"	39.90	35.90	33.90	31.90

UNBLEACHED COTTON MUSLIN

Active Foam procures some of the finest muslin for the furniture upholstery industry. Our muslin has a soft heavy hand that is easy to work with. Approximately 3 - 4 oz. goods.



48" Width	44 x 40 Thread Count	100% Cotton		
48" WIDTH	YARD	50 YARDS	100 YARDS	200 YARDS
	7.70	6.50	5.90	5.70

BLEACHED POLY COTTON MUSLIN

Weave: Twill 78 x 54 Thread Count 70/30 Poly/Cotton Blend



60" WIDTH	YARD	50 YARDS	100 YARDS
	10.32	8.92	8.42

DOWNPROOF TICKING

Bleached White - Soft Finish - A Fine High Thread Count: 43" 104 x 76
Down is available on page 89. 61" 133 x 72



43" WIDTH	YARD	25 YARDS	50 YARDS	100 YARDS
	12.70	10.90	10.10	9.30
61" WIDTH	YARD	25 YARDS	50 YARDS	100 YARDS
	15.20	13.40	12.60	11.80

CAL TB 117-2013 DOWNPROOF TICKING

A Flame Retardant Free Down Proof Ticking that is designed to meet California Technical Bulletin #117-2013.

Bleached White - Poly Cotton Blend - A Fine High Thread Count of 104 x 76



63" WIDTH	YARD	25 YARDS	50 YARDS	100 YARDS
	12.70	10.90	10.10	9.30

WOVEN BLACK CAMBRIC

RAINBOW DUST COVER

Weight: 3½-4oz

A heavy cotton blend with a high thread count.



36" WIDTH	YARD	25 YARDS	50 YARDS	100 YARDS
	6.54	5.44	4.94	4.64
46" WIDTH	YARD	25 YARDS	50 YARDS	100 YARDS
	8.18	6.80	6.18	5.80
54" WIDTH	YARD	25 YARDS	50 YARDS	100 YARDS
	9.82	8.16	7.42	6.96

WOVEN STRIPED MATTRESS TICKING

ROLL LENGTH: 75 YARDS
REPEAT: ½"
THREAD COUNT: 72X44
WEIGHT: 6.8oz
ACA TICKING: BLUE / WHITE STRIPE

CONTENTS: 100% COTTON
CFR 1632, Cig. Ignition: Pass
NFPA 701: Pass
Color Fastness to Laundering: AATCC 61 Class 4



45" WIDTH	YARD	10 YARDS	25 YARDS	75 YARDS
	18.70	16.70	15.70	14.70

DRAPERY LINING

COLOR
Bleached White
Ivory

POLY/
COTTON
70/30
65/35

THREAD
COUNT
78 x 44
78 x 44



	YARD	10 YARDS	50 YARDS	100 YARDS
54" WHITE	8.80	6.80	6.10	5.70
54" IVORY	8.80	6.80	6.10	5.70

DRAPERY LINING: SONATA SATEEN

• Water Repellent • Wrinkle Resistant • High Luster

The lining dubbed "Timeless Elegance" brings back the look and feel of sateen drapery lining of years past. Imagine the feel of cotton without the wrinkling and sun degradation problems! It's true 5-harness sateen weave along with a polished calendar finish providing a luster that is not overly offensive or shiny. Often used exclusively by quality oriented drapery workrooms when fabricating custom draperies. The Sonata Sateen provides the perfect answer for decorators, workrooms, etc who are looking for the perfect high quality lining that is "second to none", and stands alone in top quality, performance and price. With a look and feel like cotton, it is perfect for lining.

POLY/
COTTON
50/50

THREAD
COUNT
96 x 60



54" WHITE	YARD	10 YARDS	50 YARDS	100 YARDS
	11.30	10.30	9.80	9.20

CLEAR VINYL / FURNITURE COVERS

Clear vinyl rolled with interlining for furniture covers.
Can also be used for storm windows.
For clear vinyl for boat windows, see page 163.

WIDTH: 54"



	YDS/RL	YARD	10 YARDS	ROLL
12 GAUGE	33	11.70	9.00	8.40
16 GAUGE	25	15.30	13.00	11.00

ANTI-BACTERIAL HOSPITAL TICKING

SPECIFICS

- Weight: 8.0oz
- Width: 56"
- Cold Crack: -40 Degrees F
- Abrasion: (Method: 5970) 20+

FLAME RESISTANCE

- NFPA 701 (small scale) PASS
- California Fire Marshall PASS
- DOC-FF-4-72 PASS

ANTI-BACTERIAL

- Staphylococcus Aureus (gram positive) max survival 1%
- Klebsiella pneumoniae (gram negative) max survival 2%
- Draize Primary Skin Irritation Index 0

**COLOR
GREEN**

56" WIDTH	YARD	20 YARDS	40 YARDS	80 YARDS
	13.20	11.20	10.20	9.20

RUBBERIZED CURLED HAIR

Made from 100% natural fibers which are spun into an efficient, high loft, interlocking web, then bonded to a fiberglass scrim backing using a premium latex binder to produce a resilient, durable mechanical insulator pad. Our Paratex® Insulator Pads provide a durable separation layer between the base springs and layers of cushioning.

THICKNESS	FIRMNESS	PER FOOT	25 FT	75 FT ROLLS
½"	Firm	5.60	115.00	307.50
1"	Medium	5.80	120.00	322.50
1½"	Medium	7.90	172.50	480.00



POLYFLEX

A unique combination of cellulose and synthetic fillers give Perflex Edging the greatest strength and resilience available. The white synthetic cover and lip are extra strong for sewing or stapling.

SIZE	COIL	COIL	4 COILS	SIZE	COIL	BULK COIL
1/2"	50'	20.80	15.60	1/2"	2000'	395.60
3/4"	50'	27.80	22.00	3/4"	800'	215.20
1"	50'	35.60	29.20	1"	600'	245.80
1 1/4"	50'	45.20	38.20	1 1/4"	450'	250.40
1 1/2"	50'	58.00	50.20	1 1/2"	350'	278.00

White Synthetic
Cover & Fill



ECONOMY ROLL EDGE

SIZE	COIL	COIL	4 COILS
1/2"	50'	51.00	43.80
3/4"	50'	65.80	57.80
1"	50'	84.60	75.80
1 1/4"	50'	112.80	102.60
1 1/2"	50'	163.00	150.20

A tough 10 oz. burlap cover gives this edging a traditional feel and texture. Synthetic and cellulose fillers gives our burlap covered edging superior strength and resilience.

Jute Covered
White Fill



CELUFLEX SPRING EDGE

Jute and synthetic fillers with the traditional burlap cover gives this spring edge its unique durability. A double stitched lip creates the tear drop shape.

SIZE	SMALL COIL	COIL	4 COILS	SIZE	BULK COIL	COIL
1 1/2"	50'	191.20	176.60	1 1/2"	300'	813.60



CLIP-ON EDGING - 50' COIL

A tough spun-bonded synthetic cover over a synthetic/paper filler with built in positioning stakes means perfect alignment. Stakes prespaced 1 1/2" apart for "hog ring" assembly. Synthetic and cellulose fillers make "Clip-On" a firm and durable edging.

SIZE	COIL	COIL	4 COILS
1 1/2"	50'	80.80	72.40



TRIM-FLEX EDGE-ROLL

Trim-Flex is a Polyethylene Edge-Roll that contours easily around the most demanding shapes. Easy to use, very clean, and durable.

	SIZE	50' ROLL	BULK	FT/CL
PER ROLL	1/2"	22.00	348.00	1,500
PER ROLL	3/4"	26.00	219.80	700
PER ROLL	1"	33.00	224.00	500

America's Easy to us "Thumb-Roll"

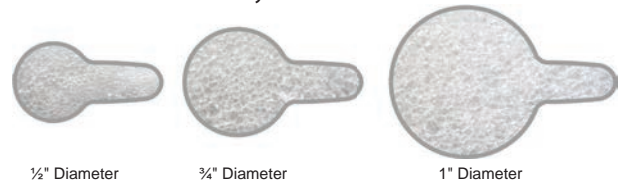

RING-FLEX EDGE-ROLL

Construction: High Density P.E.

For use in place of Cel-U-Flex

	SIZE	50' ROLL	BULK	FT/CL
PER ROLL	1"	53.00	255.00	300
PER ROLL	1 1/4"	66.00	223.20	200



PILLOW FORMS *SQUARE*

PREMIUM POLYESTER FILL



WOVEN POLY/COTTON TICKING

Polyester filled pillows in a white woven poly/cotton ticking. A most economical alternative even when making pillows from scratch. The pillow sizes are based on cut sizes, not finished sizes. Please make allowances.

KNIFE EDGED - SQUARE FORMS

	FILL WT	EACH	MIXED DOZ	DOZEN	4 DOZEN
12" x 12"	5	11.00	9.40	8.50	7.80
14" x 14"	7.5	13.60	11.50	10.60	9.80
16" x 16"	10	15.90	13.60	12.50	11.60
18" x 18"	13	18.60	15.80	14.70	13.70
20" x 20"	16	21.60	18.50	17.30	16.00
22" x 22"	19	25.30	21.60	20.40	18.90
24" x 24"	23	29.90	25.50	24.20	22.40
26" x 26"	28	35.30	30.10	28.60	26.60
28" x 28"	34	42.00	35.90	34.20	31.80
30" x 30"	40	48.90	41.80	40.00	37.10

ROUND BOLSTER PILLOW FORMS

PREMIUM POLYESTER FILL



WOVEN POLY/COTTON TICKING

DIA x LENGTH	FILL WT	EACH	MIXED DOZ	DOZEN	4 DOZEN
6" x 14"	7½	19.60	16.70	15.40	14.40
6½" x 17½"	12	24.00	20.50	19.30	17.90

RECTANGULAR PILLOW SHAM FORMS

PREMIUM POLYESTER FILL



WOVEN POLY/COTTON TICKING

HT x WIDTH	FILL WT	EACH	MIXED DOZ	DOZEN	4 DOZEN
12" x 16"	8	14.50	12.40	11.30	10.50
12" x 18"	9	16.10	13.80	12.70	11.80
14" x 20"	12	18.70	16.00	14.90	13.80

MICRO DOWN PILLOW FORMS

100% MICRO-FIBER FILL



BRUSHED MICRO-FIBER 230 COUNT TICKING

The Micro-Fiber gives you an unmistakable high end lush feel. An alternative to Down. The pillow sizes are based on cut sizes, not finished sizes. Please make allowances.

KNIFE EDGED - SQUARE FORMS

Melt Away Into the Silky Suppleness of MICRO DOWN!

	FILL WT	EACH	MIXED DOZ	DOZEN	4 DOZEN
16" x 16"	10	25.10	21.30	19.80	18.40
18" x 18"	13.0	28.70	24.40	22.80	21.20
20" x 20"	16	36.10	30.80	28.80	26.80
22" x 22"	19	44.40	37.80	35.60	33.10
24" x 24"	23	51.40	43.80	41.30	38.40
27" x 27"	28	65.00	55.40	52.40	48.70
30" x 30"	34	84.00	71.60	67.80	63.10

DOWN PILLOWS

CUSTOM SIZES AND FILLS AVAILABLE

Pre-made duck down pillows offer you a great convenience. You can offer them to your customers without the costly expense of stocking the down and the ticking. Easily sell high quality down pillows without the muss and the mess!! Other down fills are available.

180 COUNT DOWNPROOF TICKING



	10/90 Down				25/75 Down			
	EACH	SIX	DOZ	2 DOZ	EACH	SIX	DOZ	2 DOZ
16" x 16"	28.20	25.20	24.20	21.70	37.20	34.60	33.60	31.20
18" x 18"	32.00	28.80	27.80	25.30	47.40	44.90	43.90	41.50
20" x 20"	37.00	33.20	32.20	29.70	57.40	54.80	53.80	51.40
22" x 22"	43.80	39.90	38.60	35.80	73.00	70.50	69.50	67.10
24" x 24"	50.60	46.70	45.20	42.30	89.80	87.30	86.30	83.90
26" x 26"	60.20	55.70	54.10	50.90	114.00	111.40	110.40	108.00
28" x 28"	77.00	64.00	63.40	60.90	139.60	137.10	136.10	133.70
30" x 30"	91.20	76.10	75.10	72.60	165.20	162.60	161.60	159.20

A QUALITY DOWN FILL MAKES THESE PILLOWS A GREAT BUY!

KAPOK PILLOW



Ticking: 50/50 Poly-Cotton
with a 78/84 thread count
100% Virgin imported Kapok
For that natural classic luxurious feel!

18" SQUARE

EACH
34.90

BASKETBALL PILLOWS



12" Sphere - Two Choices of Down

	EACH	FOUR	DOZEN
10/90 DOWN	89.40	85.30	75.80
25/75 DOWN	129.20	125.20	112.10

DOWN

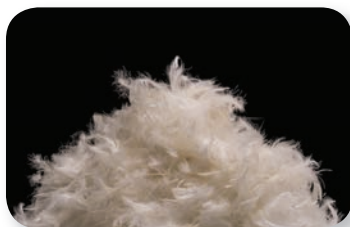

CONVENIENT
5 POUND BAGS

Downproof Ticking
on Page 85

	5 LB BAGS	10 LBS	20 LBS	25 LB BAG
10%/90% White Goose	23.20/lb (116.00/Bag)	21.10/lb (211.00/Total)	19.10/lb (382.00/Total)	15.60/lb (390.00/Bag)
25%/75% White Goose	30.80/lb (154.00/Bag)	28.80/lb (288.00/Total)	26.80/lb (536.00/Total)	25.20/lb (630.00/Bag)
50%/50% White Goose	47.40/lb (237.00/bag)	45.40/lb (454.00/Total)	43.40/lb (868.00/Total)	40.60/lb (1,015.00/Bag)
100% White Duck	114.40/lb (572.00/ Bag)	112.30/lb (1,123.00/Total)	110.30/lb (2,206.00/Total)	108.80/lb (2,720.00/Bag)

LOOSE HAIR

All New Hair
15/85 Horse/Hog
100% European Animal
Cleaned And Sterilized
15LB Box for shipping UPS.



	POUND	15 LB BOX	25 LB BAG
15/85 Horse/Hog	38.90	36.40	33.50

KAPOK NEW SILK FLOSS - A GREAT PILLOW FILLER!

Kapok does not mat together. It is used as stuffing or padding in mattresses, cushions, upholstery. Because it floats and does not soak up water, kapok used to be very common in life saving equipment until more modern synthetics replaced it. In water, kapok can support six times its weight.



	5 LB BAG	25 LB BAG
PER LB (TOTAL)	12.80 (64.00)	11.40 (285.00)

UPHOLSTERY SPRINGS

OPEN ENDED

The statistics are approximate, precise put-ups are difficult to control, please use them as rule of thumb. If exact number of pieces are ordered, no matter the quantity, they will be priced as broken bundles. The springs stocked for immediate shipment are considered "medium" in firmness. Hard and soft springs can be special ordered with a minimum of 100 pounds and approximately 4 weeks delivery.



HEIGHT GAUGE	Weight Bundle	Pieces Bundle	Pieces Lb.	EACH	BUNDLE	3 BNDLS	6 BNDLS
4" 9	25# Approx	100	4.0	2.70/@	5.98/lb	5.58/lb	5.18/lb
5" 9	25# Approx	87	3.5	2.92/@	5.98/lb	5.58/lb	5.18/lb
6" 9	25# Approx	80	3.2	3.08/@	5.98/lb	5.58/lb	5.18/lb
7" 9	25# Approx	72	2.9	3.26/@	5.98/lb	5.58/lb	5.18/lb
8" 9	25# Approx	67	2.7	3.42/@	5.98/lb	5.58/lb	5.18/lb
9" 9	25# Approx	62	2.5	3.60/@	5.98/lb	5.58/lb	5.18/lb
10" 9	25# Approx	57	2.3	3.90/@	5.98/lb	5.58/lb	5.18/lb
11" 9	25# Approx	55	2.2	4.02/@	5.98/lb	5.58/lb	5.18/lb
12" 9	25# Approx	52	2.1	4.16/@	5.98/lb	5.58/lb	5.18/lb

PILLOW SPRINGS



222 Pieces / 30 Lb Bundle

SIZE	GAUGE	EACH	BUNDLE
8"	13	2.20/@	8.60/lb

"X" TOP

Priced Per Each

Upholstery Springs
9 Gauge

SIZE	EACH	12	24
8"	7.10	5.90	5.30
9"	7.50	6.30	5.70
10"	8.00	6.80	6.20



EDGEWIRE CLIPS

Tools: 3 Prong Clip Pliers on Page 138

Pcs/Lb
Width

No. 3	No. 32
111	95
1-1/8"	1-1/4"



No. 3
Fully Lined

No. 32
Non-Lined

	POUND	5 LBS	10 LBS	25 LBS
No. 3 Fully Lined	18.00	16.00	14.80	14.40
No. 32 Non-Lined	15.00	13.00	12.00	10.40

Per Lb
Per Lb

BW CLIPS/C-CLIPS

Tools: #522 BW Clip Pliers on Page 138

Pieces per Lb: 100

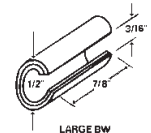

FULLY LINED

LARGE BW

PER POUND	POUND	5 LBS	10 LBS	25 LBS
	16.80	14.80	13.20	12.00

Per Lb

TORSION SPRINGS

10 GAUGE
DOUBLE TURN

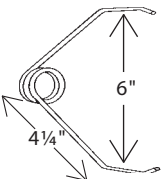

On the corners of davenport where the edge wire is bent to form this corner, additional spring support is usually needed. One end of the torsion spring is clipped to the edge wire and the other end is nailed to the frame to provide this support. Made from 10 gauge wire.

PER EACH	PIECE	PER 10	PER 100
	3.86	3.16	1.96

KLINCH-IT CLIPS



650 / BOX
5,000 / BOX
HAND TOOL

EACH
91.40
517.50
700.20

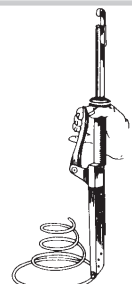

NO-SAG SPRINGS



- Please inquire for other available lengths & gauges.
- Please inquire for quotations.
- Available: Cut to Length springs at no extra charge
(1,000 piece minimum)



- Loop Repeat: 7/8"
- Loop Width: 1-7/8"

GAUGE	USE	Ft./ROLL	WEIGHT	ROLL	4 ROLLS	10 ROLLS
8	Seats	111	22¼ lbs	116.40	108.00	97.00
8½	Seats	111	20½ lbs	108.10	100.30	90.10
9	Seats	120	18¾ lbs	111.10	103.00	92.60
10	Backs	127	15¼ lbs	105.50	99.80	88.40
11	Backs	140	15¼ lbs	103.10	96.30	87.00
12	Backs	154	15¼ lbs	103.10	96.20	86.90

SPRING CLIPS

- The "G" clip is used the same as the EK Clip. It holds the zig zag spring wire slightly below the edge of the frame rather than on top.
- The "SS" clip is used identically as the EK Clip. It only differs in its application. It is slotted versus holes, allowing for staples to fasten the clip to the frame very easily.

FULLY LINED CLIPS



	PIECES/LB	POUND	10 LBS	25 LBS	50 LBS
EK Clips	100	15.00	12.00	10.60	9.80
SS Clips	100	15.00	12.00	10.60	9.80
G Clips	55	15.00	12.00	10.60	9.80

1" EK NAILS: RING BARBED



1" Ring Barbed

PER LB:	POUND	5 LB	10 LB	25 LB
	14.60	12.60	11.60	10.90

HELICALS

Lengths are measured from the inside to inside of each hook on the helical.



Closed Wound: 15 Gauge Seats
2" 35 per Pound
3" 19 per Pound



Open Wound: 17 Gauge Backs
2" 91 per Pound
3" 51 per Pound

TYPE	SIZES	EACH	20	100	500	TYPE	SIZES	EACH	20	100	500
SEAT	2"	1.06	.86	.76	.62	BACK	2"	.86	.66	.58	.48
SEAT	3"	1.24	1.04	.92	.76	BACK	3"	1.10	.90	.80	.66

EDGEWIRE

9 Gauge Wire ¾ Lb Per Piece



	PIECE	25	50	100
12 Foot Lengths	5.58	4.66	4.38	3.86

STAKEWIRE

16 Gauge Wire Oil Tempered
Kraft Paper Wrapped
Stiff Welt Cord for Loose Backs
Stablizer Wire for NoSag Springs



16 GAUGE: REGULAR			150Ft COIL	4,000Ft COIL
GAUGE	TYPE	LENGTH	50.20	585.60
16	REG.	54"	3.00	1.20
12	HEAVY	48"	3.46	1.66
			25	100
			0.96	0.80
			1.42	1.26

No SAG TOOLS

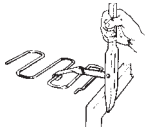

**OSBORNE
STRETCHER**
#268 68.60

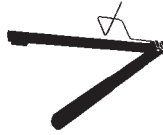

**OSBORNE
BENDER**
#1963 124.90



**OSBORNE
BENDER**
#404 103.40

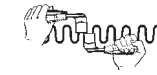

**OSBORNE
BENDER**
#401 108.00

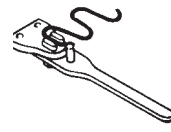

**No-SAG
BENDER**
#720 850.80



**OSBORNE
CUTTER**
#719 1163.30

SPRING CLIPPING TOOL

FEATURES AND BENEFITS
Surface clinching tool squeezes instead of folding the clip around wires, fastening and forming the clip into a tight, strong wire bond.

APPLICATION

- Clipping larger gauge sinuous seat and back springs to stabilizing tie wire.
- Clipping coil seat springs to border wires in 8-way hand tie upholstered unit application.



Spring Clip Tool: HR-66C-10

1660.00

3 Prong Clips

**CLIPS/BOX
2,880**



**PER BOX
158.50**

RUBBER BANDS

2.5" LENGTHS

100/LB

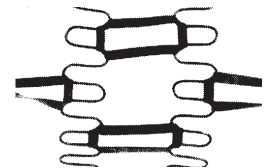

PER LB

**POUND
46.40**

**5 LBS
42.40**

**10 LBS
38.40**

ZIG ZAG REPAIR BRACKET KIT



These clips repair furniture where zig zag springs have broken off at the rail. The repair can be done quickly and easily from the bottom.

SET	PIECE	25PCS	100PCS
	2.36	1.48	1.36

SPRING & WIRE REPAIR KIT

10 Connector Assortment
8 Straight, 1 90°, 1 45°

#1776 CONNECTOR REPAIR KIT

ASSORTMENT	EACH
	86.40
90 DEGREE (10)	89.00
45 DEGREE (10)	89.00

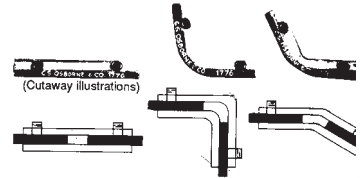

CONNECTING TUBES

Whenever two pieces of edge wire must be joined together, these metal tubes are used to hold them securely in place. Approximately 67 pieces per pound.

**2.5" WIDE
FOR 9 GAUGE WIRE**

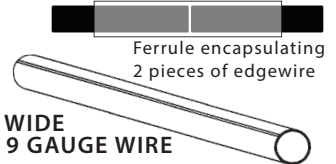

EACH	10	25	100
1.02	.72	.50	.38

CONNECTING LINKS

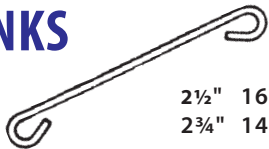

2 1/2" 160 / LB
2 3/4" 140 / LB

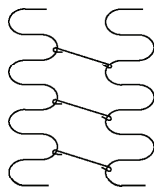

LENGTH	1LB	5LBS	10LBS	25LBS
2 1/2"	15.90	13.70	12.30	10.60
2 3/4"	18.00	15.60	14.00	12.10

HINGE LINKS

105 Pieces / Lb

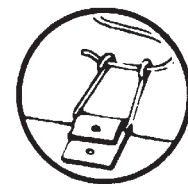
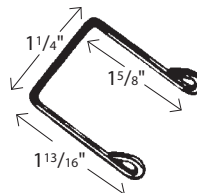

PER LB	1 LB	5 LBS	10 LBS	25 LBS
	17.30	14.20	11.30	10.00

PLATFORM ROCKER UNITS: 13 GAUGE

EXTRA FIRM



HEIGHTS: 2½" 3½" 5.0"

3" Diameter - Hog Ringed - Vantex Covered Coils - 25 Per Bale

HT	COILS	DIMENSIONS	PIECE	THREE	DOZEN	BALE
2½"	7 X 7	21" x 21"	65.10	61.10	58.10	55.60
3½"	7 X 7	21" x 21"	70.10	66.10	63.10	60.60
5"	7 X 7	21" x 21"	74.90	70.90	67.90	65.40

MARSHALL CUSHIONS: 14 GAUGE

MEDIUM FIRM



HEIGHTS: 3½"

3" Diameter - Hog Ringed - Vantex Covered Coils

HT	COILS	DIMENSIONS	PIECE	THREE	DOZEN	BALE
3½"	6 X 7	18" x 21"	55.80	51.80	48.80	46.30
3½"	7 X 7	21" x 21"	63.20	59.20	56.20	53.70

MARSHALL CUSHIONS: 15 GAUGE

MEDIUM



HEIGHTS: 3½"

3" Diameter - Hog Ringed - Vantex Covered Coils

HT	COILS	DIMENSIONS	PIECE	THREE	DOZEN	BALE
3½"	6 X 7	18" x 21"	54.00	50.00	47.00	44.50
3½"	7 X 7	21" x 21"	61.20	57.20	54.20	51.70

LAWSON BACK UNITS: 15 GAUGE

SOFT



HEIGHTS: 5"

3" Diameter - Hog Ringed - Vantex Covered Coils

HT	COILS	DIMENSIONS	PIECE	THREE	DOZEN	BALE
5"	7 X 8	21" x 24"	69.30	65.30	62.30	59.80

DOWN CUSHIONS: 16 GAUGE

SUPER SOFT



HEIGHTS: 2½" 3½" 5"

3" Diameter - Hog Ringed - Vantex Covered Coils

HT	COILS	DIMENSIONS	PIECE	THREE	DOZEN	BALE
2½"	7 X 7	21" x 21"	58.90	54.90	51.90	49.40
3½"	7 X 7	21" x 21"	60.20	56.20	53.20	50.70
5"	7 X 8	21" x 24"	67.50	63.50	60.50	58.00

SWIVEL ROCKER BASES

- 5 leg - 5 spring - 25" spread
- 9" diameter round bottom plate - maximum strength
- 5-leg construction with 3 solid rivets per leg
- Extra-large center stake rivet
- Lubricated raceway with 8 ball bearings
- 5-spring construction
- Center pivot allows for smooth rock and stability of upholstered chair
- Leg crimped around leg glide for longer lasting attachment.
- Hole mounts: 5¾" x 8½"
- Height: measured from the floor to top of the plate on the front edge.



Sizes:
5" High
&
6" High

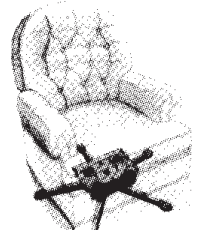

TYPE
REG. STANDARD DUTY

HEIGHTS
5" OR 6"

EACH
119.90

3 UNITS
117.90

6 UNITS
115.90

SWIVEL BASE ONLY

Size: 3.75" High



- 5 leg - 25" spread
- 9" diameter round bottom plate
- Extra-large center stake rivet
- Prelubed raceway with 8 ball bearings
- Flat top plate design
- Leg crimped around leg glide for longer lasting attachment.
- Hole mounts: 5¾" x 5¾"

HEIGHT
3.75"

EACH
84.70

3 UNITS
82.70

6 UNITS
80.70

REPLACEMENT ROCKER SPRINGS & BOX

REPLACEMENT SPRINGS: FRONT, BACK, OR CENTER

	EACH
PER SPRING: FRONT	6.20
PER SPRING: BACK	6.20
PER SPRING: CENTER	6.10



SWIVEL BOX **EACH**
76.50

PLATFORM ROCKER SPRINGS

Regular Duty Applications: 8 Gauge Coils

Standard size, highest quality spring wire coils held by sturdy brackets stamped from .059 steel. Designed for durability & built to last. Double coil, 8 turns.

Heavy Duty Special Applications: 7 Gauge Coils

Standard size, highest quality spring wire coils held by sturdy brackets stamped from .074 steel. Designed for durability & built to last. Double coil, 8 turns.

Regular 8 Gauge
Heavy Duty 7 Gauge

PAIR	10 PAIR
27.70	24.50
28.30	25.00



Size" 3¾" W x 5" L x 2¼" H

JUVENILE ROCKER SPRINGS

Regular Duty Applications: 8 Gauge Coils

Standard size, highest quality spring wire coils held by sturdy brackets stamped from .059 steel. Designed for durability & built to last. Double coil, 7 turns.

Regular 8 Gauge

PAIR	10 PAIR
25.10	22.30



Size" 3¾" W x 2½" L x 2¼" H

SWIVELS/REVOLVING PLATES

Standard Swivels - Memory Swivels - Pitched Swivels



	TYPE	ANGLE	INCHES BETWEEN HOLES	EACH	SIX	DOZEN
7" X 7"	REGULAR	0	5.25"	26.00	23.00	22.00
7" X 7"	REGULAR	3	5.25"	27.30	24.30	23.30
8" X 8"	MEMORY	0	5.75"	42.00	39.00	38.00
8" X 8"	MEMORY	3	5.75"	48.40	43.40	42.40
10" X 10"	REGULAR	0	8.00"	59.90	56.90	55.90
11½" X 11½"	REGULAR	0	10.375"	68.50	65.50	61.50

HIDE-A-BED DECKING

A woven polypropylene fabric used as a decking underneath the mattress.

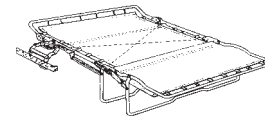

60" WIDTH	YARD	10 YDS	25 YDS
	12.60	10.40	9.60

HIDE-A-BED SOFA SLEEPER MECHANISM

TWIN SIZE 820.00
Includes 5" Inner-Spring Mattress
Mounting Width: 44"
Mattress Only(5"x36"x72"): \$392.00

FULL SIZE 904.00
Includes 6" Inner-Spring Mattress
Mounting Width: 60"
Mattress Only(6"x54"x72"): \$412.00

QUEEN SIZE 974.00
Includes 6" Inner-Spring Mattress
Mounting Width: 68"
Mattress Only(6"x60"x72"): \$464.00

KING SIZE 1478.00 Special Order
Includes 5½" Inner-Spring Mattress
Mounting Width(5½"x65"x72"): 72"

- The new standard for product quality
- All tubular perimeter - contoured seat section
- Advanced linkage design
- Streamlined side profile with dual tubular legs

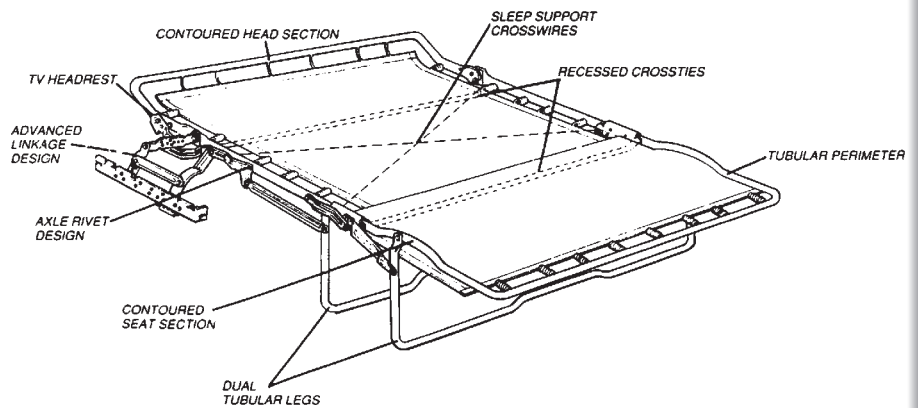

Heavy Gauge Helicals: 2 5/8"
\$2.00/Ea \$38.40/24

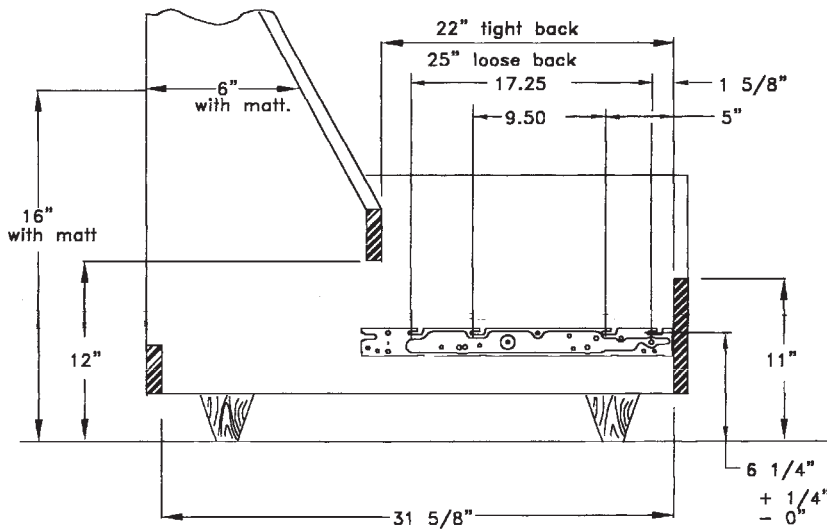

NEW 6" Mattresses!

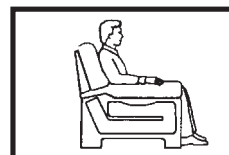

Contoured seat section

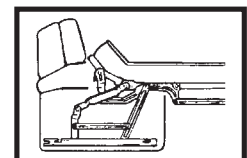

Double locking T.V. headrest



Positive Lock System

METAL TREAD BALL CASTERS: 2½" PLANET

shepherd® casters

STEMS
SOLD
SEPARATELY

ALL
CASTERS
PRICED
PER PIECE



Brass

EACH	16	40
	16.20	14.20



Chrome

EACH	16	40
	20.00	18.00



Windsor Antique

EACH	16	40
	15.10	13.10



Brass w/ brake

EACH	16	40
	24.50	22.50

PLANET will accept the 02, 25, 88/23, 87/22, 07 stems as well as the 01 plate.

DYNAMIC: 100 MOBIILITY: A STATIC: 950 MOUNTING: 3"
LOAD: 100 CLASS: A LOAD: 950 HEIGHT: 3"

METAL TREAD BALL CASTERS: 2" SATELLITE

shepherd® casters

STEMS
SOLD
SEPARATELY

ALL
CASTERS
PRICED
PER PIECE



Brass

EACH	16	40
	12.80	10.80



Chrome

EACH	16	40
	17.80	15.80



Windsor Antique

EACH	16	40
	11.20	9.20

SATELLITE will accept the 02, 26, 25, 88/23, 87/22, 82/11, 07, 05 stems as well as the 01 plate.

DYNAMIC: 75 MOBIILITY: A STATIC: 675 MOUNTING: 2 1/2"
LOAD: 75 CLASS: A LOAD: 675 HEIGHT: 2 1/2"

METAL TREAD BALL CASTERS: 1½" STARLET

shepherd® casters

STEMS
SOLD
SEPARATELY

ALL
CASTERS
PRICED
PER PIECE



Brass

EACH	16	40
	14.30	12.30



Chrome

EACH	16	40
	12.50	10.50



Windsor Antique

EACH	16	40
	11.70	9.70

STARLET will accept the 02 stem as well as the 1R plate.

DYNAMIC: 40 MOBIILITY: D STATIC: 525 MOUNTING: 1 1/2"
LOAD: 40 CLASS: D LOAD: 525 HEIGHT: 1 1/2"

RUBBER TREAD BALL CASTERS

shepherd[®] casters

For Wood & Other Hard Surfaced Floors

STEMS
SOLD
SEPARATELY

ALL
CASTERS
PRICED
PER PIECE



Nova 2 1/4" Brass
EACH 16 40
21.20 20.20 19.20



Nova 2 1/4" Chrome
EACH 16 40
24.70 23.70 22.70



Nova 2 1/4" W. Antique
EACH 16 40
22.40 21.40 20.40



Saturn 3" Brass
EACH 16 40
24.50 23.50 22.50

NOVA will accept the 02,26, 25, 88/23, 87/22, 82/11,07,05 stems & the 01 plate.
DYNAMIC:75 MOBILITY:G STATIC:G MOUNTING:2 1/8" HEIGHT:2 1/8" LOAD:75 CLASS:G LOAD:750

SATURN will accept the 02,25, 88/23, 87/22,07 stems & the 01 plate.
DYNAMIC:100 MOBILITY:F STATIC:F MOUNTING:3 1/4" HEIGHT:3 1/4" LOAD:100 CLASS:F LOAD:925

TWIN WHEEL CASTERS

shepherd[®] casters

STEMS
SOLD
SEPARATELY

ALL
CASTERS
PRICED
PER PIECE



Pacer50 2" Brass
EACH 16 40
20.40 19.40 18.40



Pacer50 2" Chrome
EACH 16 40
13.80 12.80 11.80



Pacer60 2 3/8" Brass
EACH 16 40
22.20 21.20 20.20



Pacer60 2 3/8" Chrome
EACH 16 40
18.80 17.80 16.80

PACER50 will accept the 02,26, 25, 88/23, 87/22, 82/11,07,05 stems & the 01 plate.
DYNAMIC:75 MOBILITY:A STATIC:A MOUNTING:2 1/4" HEIGHT:2 1/4" LOAD:75 CLASS:A LOAD:650

PACER60 will accept the 02,25, 88/23, 87/22,07 stems & the 01 plate.
DYNAMIC:100 MOBILITY:A STATIC:A MOUNTING:2 3/8" HEIGHT:2 3/8" LOAD:100 CLASS:A LOAD:725

HOODED BALL CASTERS

shepherd[®] casters

ALL
CASTERS
PRICED
PER PIECE

The Chrome is available fitted with three popular stems: "02" wood stem, "87/22" ring stem, and the "26" threaded stem. The Windsor Antique finish is available only with the "02" stem. Since the Baron stem cannot be inter-changed, these are the only stems available.



Baron16 1 5/8" W. Antique
EACH 16 40
13.60 12.60 11.60



Baron20 2" W. Antique
EACH 16 40
13.60 12.60 11.60













Baron20 2" Chrome
EACH 16 40
13.60 12.60 11.60



DYNAMIC:75 MOBILITY:G STATIC:G MOUNTING:2 1/8" HEIGHT:2 1/8" LOAD:75 CLASS:G LOAD:625

DYNAMIC:80 MOBILITY:E STATIC:E MOUNTING:2 1/2" HEIGHT:2 1/2" LOAD:80 CLASS:E LOAD:725

ANTIQUE CASTERS: BRASS

Square Top			Square Top			Square Top			Round Top			Round Top		
														
Discontinued (Stock may be available)									Discontinued (Stock may be available)					
INSIDE CUP	WHEEL DIA	RAISES FURN.	INSIDE CUP	WHEEL DIA	RAISES FURN.	INSIDE CUP	WHEEL DIA	RAISES FURN.	INSIDE CUP	WHEEL DIA	RAISES FURN.	INSIDE CUP	WHEEL DIA	RAISES FURN.
3/4"	3/4"	1"	1"	1"	1 1/4"	1 1/4"	1 1/4"	1 1/2"	3/4"	3/4"	1"	1"	1"	1 1/4"
EACH	4	12	EACH	4	12	EACH	4	12	EACH	4	12	EACH	4	12
28.10	25.10	22.10	33.30	30.30	27.30	35.90	32.90	29.90	29.30	26.30	23.30	31.80	28.80	25.80

Round Top			Philly Drive Stem Brass			Philly Drive Stem Brass			Philly Drive Stem Brass			Cast Iron Stem Porcelain		
														
									Discontinued (Stock may be available)					
INSIDE CUP	WHEEL DIA	RAISES FURN.	WHEEL DIA	RAISES FURN.	WHEEL DIA	RAISES FURN.	WHEEL DIA	RAISES FURN.	WHEEL DIA	RAISES FURN.	WHEEL DIA	RAISES FURN.	WHEEL DIA	RAISES FURN.
1 1/4"	1 1/4"	1 1/2"	3/4"	1"	1"	1 5/8"	1 1/8"	2"	1"	1 1/2"				
EACH	4	12	EACH	4	12	EACH	4	12	EACH	4	12	EACH	4	12
33.40	30.40	27.40	23.10	20.10	17.10	25.70	22.70	19.70	30.00	27.00	24.00	16.20	13.20	10.20

Philly Drive Stem Porcelain			Philly Drive Stem Porcelain			Philly Drive Stem Porcelain			Oak Wheel w/ Stem & Socket			Oak Wheel w/ Stem & Socket		
														
Discontinued (Stock may be available)						Discontinued (Stock may be available)								
WHEEL DIA	RAISES FURN.		WHEEL DIA	RAISES FURN.	WHEEL DIA	RAISES FURN.	WHEEL DIA	RAISES FURN.	WHEEL DIA	RAISES FURN.	WHEEL DIA	RAISES FURN.	WHEEL DIA	RAISES FURN.
3/4"	1"		1"	1 3/8"	1 3/8"	2"	1 1/8"	1 1/8"	1 5/8"	2"				
EACH	4	12	EACH	4	12	EACH	4	12	EACH	4	12	EACH	4	12
26.40	23.40	20.40	25.70	22.70	19.70	36.50	33.50	30.50	9.50	6.50	3.50	10.80	7.80	4.80

STEMS & PLATES

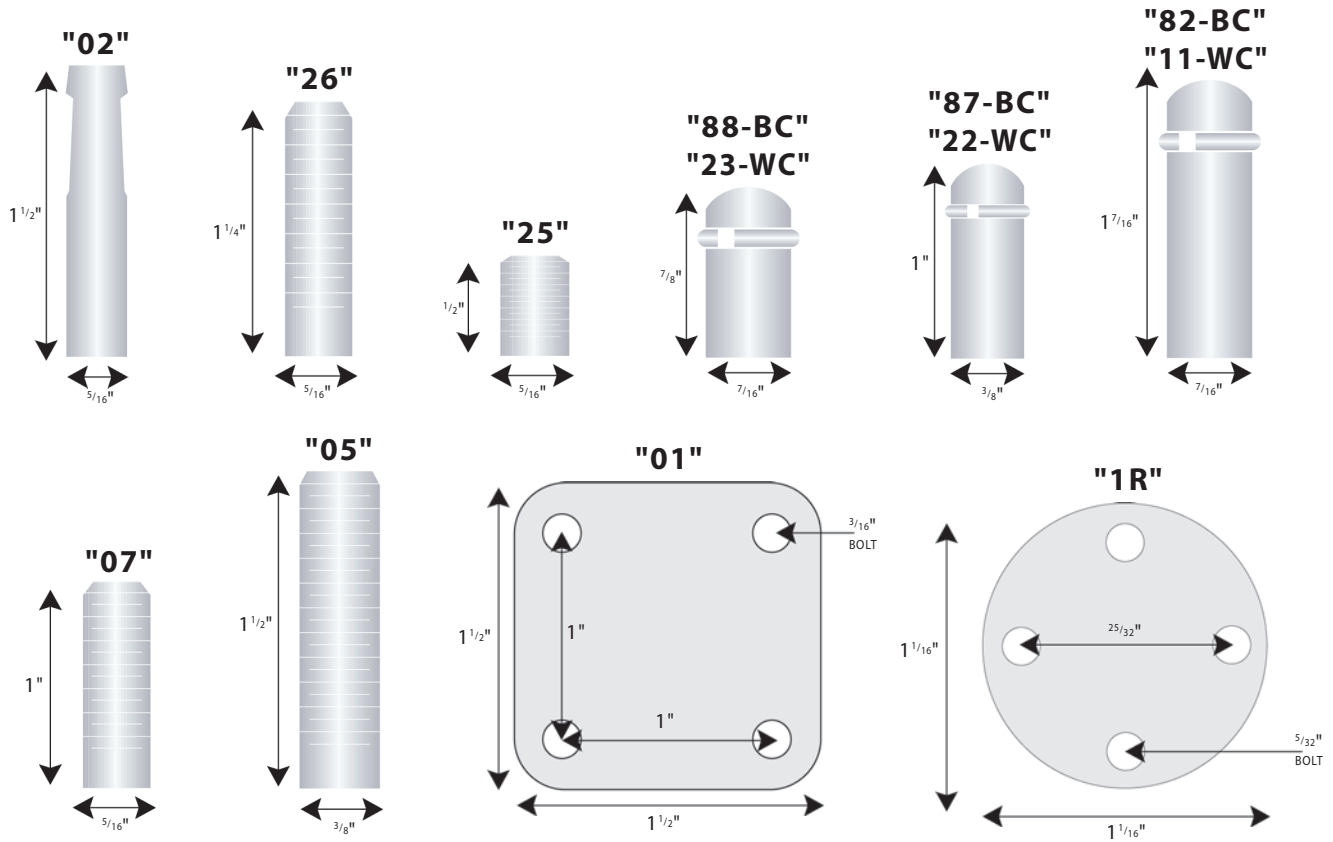

ORDERED SEPARATELY ORDERED W/CASTER
2.44 2.14

METAL SOCKETS

This metal socket is standard for all "02" stems regardless of the caster body type. Hole size for sockets: $\frac{3}{8}$ " Dia. x $1\frac{5}{8}$ ".



Metal Sockets .72

PLASTIC BUSHINGS

Fits on the end of stems and plates to fasten and lock into the body of the caster. Sized per caster stem size.



Plastic Bushings No Charge

PLASTIC SOCKETS

SOCKETS FOR ROUND TUBING
PART# SOCKET O.D. TUBING GAUGE TUBE I.D.

3027	.450	$\frac{1}{16}$ "	16 Ga.	.433
2486	.413	$\frac{3}{8}$ "	16 Ga.	.495
2489	.637	$\frac{3}{4}$ "	16 Ga.	.620
2488	.667	$\frac{3}{4}$ "	18 Ga.	.652
2491	.765	$\frac{7}{8}$ "	16 Ga.	.745
2495	.887	1"	16 Ga.	.870
2498	1.002	$1\frac{1}{16}$ "	20 Ga.	.992



SOCKETS FOR SQUARE TUBING
PART# SOCKET O.D. TUBING GAUGE TUBE I.D.

2500	.695	$\frac{3}{4}$ "	20 Ga.	.678sq
2492	.890	1"	16 Ga.	.880sq

For Use
With
"02" Stems

All Sockets EACH 24 .60

CASTER RATINGS

Static Load: The maximum one time load a caster can withstand without loss of serviceability or damage to fastening or other components.

Dynamic Load: The load a caster is designed to carry on a continuous basis and can be expected to operate within a Mobility Class as listed below.

Mobility Class: Shepherd defines four Mobility Classes covering most applications. A Mobility Class Rating says that a caster will operate for a certain number of cycles with its Dynamic Load applied. A cycle is a travel of 60 inches with one swivel.

Hard Tread Casters

Class A	100,000	cycles minimum (or BIFMA Chair rated)
Class B	50,000	cycles minimum
Class C	25,000	cycles minimum
Class D	2,000	to 10,000 cycles minimum

Soft Tread Casters

Class E	36,000	cycles minimum (or BIFMA Chair rated)
Class F	20,000	to 25,000 cycles minimum
Class G	10,000	to 15,000 cycles minimum
Class H	2,000	to 5,000 cycles minimum

KWIK-SPRAY AEROSOL ADHESIVES

WIDE WEB • SPRAY HIGH SOLIDS • FAST TACK • NO CHLORINATED SOLVENTS

This wide web spray adhesive is one of the highest performance aerosol adhesives available. For both temporary or permanent bonding, this high solids product is ideal for uneven or porous surfaces and light-weight materials. Waterproof, flexible, and orange colored, use this product for your toughest adhesive applications with materials such as urethane foam, leather, cardboard, most plastics, polyethylene sheeting and cloth. Formulated with the environment in mind, this product contains NO CHLORINATED SOLVENTS. Cleans easily with mineral spirits.

Not intended for use on paper.



#840 or #860 12oz AEROSOL	CAN 19.20	6 CANS 17.90	12 (CASE) 16.40	#840 Orange #860 Clear
---------------------------	--------------	-----------------	--------------------	---------------------------

DAP WELDWOOD TOP & TRIM SPRAY

Landau Contact Adhesive Aerosol can be used for any application that uses the bulk version!

- High temperature
- Long open time
- Web spray

- For bonding landau tops constructed of non-penetrable fabric backings and many other materials.
- High strength, high temperature-resistant bond
- Ideal for use on trim work, door panels, decorative laminates and upholstery work and a wide variety of other projects
- Professional results

Not formulated the same as the bulk DAP.



16 oz AEROSOL	CAN 26.80	6 CANS 24.00	12 (CASE) 22.80
---------------	--------------	-----------------	--------------------

SPRAYWAY: #92 FAST TAC HI-TEMP TRIM SPRAY

Formulated for the automotive professional!

- Easily bonds heavier-weight materials to metals, woods, & plastics.
- For high-temp, heavy-duty bonding of vinyl tops, headliners, & hood silencer pads.
- Excellent heat and water resistance.
- Allows repositioning during assembly



20 oz AEROSOL	CAN 26.20	12 (CASE) 23.60
---------------	--------------	--------------------

K-GRIP #201 & #203 SPRAY ADHESIVE



DESCRIPTION: This product is a synthetic elastomer based solvent adhesive designed specifically for application with low pressure spray equipment. It is made with nonflammable solvents and is recommended for various foam fabricating operations such as laminating, boxing, splicing taping and knife edging. It is recommended for bonding various types of foam to wood, metal, plastics, fabrics, etc. This product is non-dimpling and will not discolor or cause staining of cover fabrics.

APPLICATION: Is adaptable to either pressure pots or drum pumps. Nylon hoses should be used on all product lines since the nonflammable solvents used in this adhesive will soften the rubber hoses. Use with adequate ventilation.

TYPICAL PHYSICAL PROPERTIES: Viscosity: 240 cps, Solids: 28%, Weight/Gal. 10 lbs.

Base: Synthetic Elastomer

#200 SOLVENT: Used with the K-Grip #201 & #203. It is an absolute must for the best and the most consistent results. The K-Grip #200 Solvent will do the trick in thinning out the adhesive when it thickens. Thickening causes problems in spraying and drying too quickly resulting in improper adhesion between the two surfaces.



YES, YES, YES!
Spee-Dee Delivery will deliver 5-gallon pails economically without specialized, expensive packaging.

NO UPS SURTAX
NO HAZARDOUS MATERIAL SURCHARGE
FOR 1-GALLON JUGS with UPS
CERTIFIED BOXES
IL & WI Stock: #203
MI Stock: #201

	HALF GAL	GALLON	4 GAL
RED OR CLEAR #201 ADHESIVE	-	70.80	66.80
RED OR CLEAR #203 ADHESIVE	-	73.90	69.90
#200 SOLVENT	-	64.60	60.50
UPS CERTIFIED BOX	3.00		

KWIK-SPRAY #220 & #225 SPRAY ADHESIVE



*A non-flammable foam-to-foam adhesive that JUST STICKS!
An unbelievable bond within one minute!
#220 is a low viscosity formulation!*

BENEFITS

- Aggressive initial tack
- Low pressure sprayability
- High solids for good yield
- VOC free solvent system

FEATURES

- Colors: Clear or Red
- 30% Solids
- Weight / gal 10 lbs

APPLICATIONS

- Foam-to-Foam
- Foam-to-Fiber
- Foam-to-Fabric
- Foam-to-Wood
- Fabric
- Wood
- Metal
- Many plastics



YES, YES, YES!
Spee-Dee Delivery will deliver 5-gallon pails economically without specialized, expensive packaging.

NO UPS SURTAX
NO HAZARDOUS MATERIAL SURCHARGE
FOR 1-GALLON JUGS with UPS
CERTIFIED BOXES

	QUARTS	GALLON	4 GAL	5 GAL PAIL
RED OR CLEAR #220 ADHESIVE	-	82.70	78.50	361.00 (72.20)
RED OR CLEAR #225 ADHESIVE	-	82.70	78.50	361.00 (72.20)
#205 SOLVENT	32.90	75.80	8.500	320.00 (64.00)

DAP "WELDWOOD" TOP & TRIM ADHESIVE

High Heat Resistant Landau Contact Adhesive

The ideal contact cement for automotive interior applications.

Its high heat resistance is well suited for adhering headliners, fabric, and many other materials during automobile refurbishment.

Easy to apply with hot or cold spray equipment.



For bonding Landau Tops constructed of non-penetrable fabric backings and many other materials.

GALLON CANS	COLOR	GAL	2 GAL	4 GAL
	NATURAL	76.50	72.50	70.50
5 GALLON PAILS	COLOR	PAIL	2 PAIL	3 PAIL
	NATURAL	247.00	243.00	239.00
5 GALLON PAILS	RED	247.00	243.00	239.00



K-GRIP: #202 PLUS

High heat resistant spray adhesive automotive top & trim applications

Same as the K-Grip 203, except with a 215° degree heat limit.

#200 or #205 Solvent can be used as a cleaner or thinner.

DESCRIPTION: This product is a synthetic elastomer based solvent adhesive designed specifically for application with low pressure spray equipment. It is made with nonflammable solvents and is recommended for various foam fabricating operations such as laminating, boxing, splicing taping and knife edging. It is recommended for bonding various types of foam to wood, metal, plastics, fabrics, etc. This product is non-dimpling and will not discolor or cause staining of cover fabrics.

APPLICATION: Is adaptable to either pressure pots or drum pumps. Nylon hoses should be used on all product lines since the nonflammable solvents used in this adhesive will soften the rubber hoses. Use with adequate ventilation.



Per Gallon	1 GAL	4 GAL
	96.00	92.00

VINYL LIQUID PATCH

VLP is a clear, high strength, flexible adhesive designed to mend rips, tears and holes on all types of flexible vinyl surfaces. Most vinyl items can be mended with VLP including car, truck, bus and motorcycle seats, vinyl car and boat tops, rainwear, boots, furniture, luggage, inflatable balls, toys and more. VLP is supplied in a fast drying solvent base (NO HEAT REQUIRED). Dried VLP is clear and will blend with all vinyl colors. Resists deterioration when exposed to outdoor weathering conditions, including sub-zero temperatures.



- **Fast**
- **Efficient**
- **Economical**

	EACH	DOZEN
1oz TUBE	11.10	10.10
12oz BRUSH TOP CAN	35.50	33.00

HH-66 VINYL CEMENT

**GREAT VINYL REPAIR ADHESIVE
BONDS VINYL TO VINYL!**

HH-66 is a fast drying adhesive that is used extensively for bonding vinyl coated and vinyl laminated fabrics to themselves or to various materials. HH-66 is also used to bond urethanes, vinyl foams and films, rigid plastics, synthetic fabrics, wood, leather, and metals. It is outstanding for sealing or waterproofing stitched seams. HH-66 dries quickly with a very strong, yet flexible bond. It is not affected by weather and temperature extremes, and is highly resistant to oil, fuel, grease, and many other chemicals.



	EACH
16oz BRUSH TOP CAN	38.70

HOT MELT GLUE STICKS

A clear hot melt for gimps and other trims. A specially formulated high strength bond that allows you to use it on your toughest requirements. Eliminates the need to carry two types of hot melt adhesives.

Approximately: 93 sticks per 5lb Box

Hot Melt Gun on Page 107



	PACK	4PACKS	5 LB CASE	25 LBS
10" x 1/2" Clear 12 Sticks / Pack	17.70	15.70	90.40	412.00

CA SERIES ADHESIVES

Cyanoacrylate Adhesives

"Crazy Glue"



Premier

FORMULA	PUT-UP	EACH
CA Thin	2oz	24.00
CA Medium	2oz	24.00
CA Thick	2oz	24.00
DEBONDERS/REMOVERS		
Activator Pump Spray	4oz	19.80
Activator Dispenser Bottle	2oz	20.50

- Cyanoacrylate Adhesives are industrial grade adhesives.
- Adhesives developed for wood furniture and cabinet trades.
- Three viscosities to cover all of your bonding requirements.
- The CA Series is CFC free and ozone friendly.

PREMIER WOOD EPOXY

QUICK CURE

Premier

PREMIER WOOD EPOXY is a specially formulated wood repair epoxy putty which, when hand mixed (kneaded) to a uniform color, creates a lasting solution to repairs and restorations. Wood Epoxy has the same density as wood and, upon curing becomes, an integral part of the item being repaired. Wood Epoxy may be used for exterior or interior applications, contains no solvents, will not shrink, crack, rot or pullaway. Wood Epoxy has a 10 minute worklife and hardens in 15 minutes. After the final cure, wood epoxy may be sanded, drilled, tapped, sawed, rasped, machined, painted or stained.

DIRECTIONS: For best results, clean and roughen bond area prior to application. twist or cut off required amount. To mix, knead with fingers to a uniform color. Apply to surface to be repaired (within 5-10 minutes of mixing). Force into any cracks or holes to be filled and strike off excess material. For a smooth appearance of the cured compound, hand rub with water or a damp cloth prior to hardening. Remove excess material before hardening begins. After 45 minutes, the epoxy will harden and form a tenacious bond. Test for stain acceptance. Wood Epoxy may accept stain differently from wood. Some types of oil based stains may be added during the mixing step. Test for color match and hardening before application.

Wood Epoxy: 4oz Tube	EACH
	13.60



- Fills holes, scratches, gouges, and cracks
- Repair furniture, molding and frames
- Reshape wood carvings and remold wood
- Can be sanded, sawed, painted & stained

PLATINUM ADHESIVE: WEB SPRAY 150

Super Sticky Spray Adhesive

VOC Compliant

APPLICATIONS

- Carpet
- Furniture
- Bedding
- Foam to Foam
- Professional Results

FEATURES

- Fast Tack
- Quick Adhesion
- Non-Ozone Depleting
- High Solids
- Non-Staining
- Professional Results



*The Recommended Adhesive
for the
"Snap" Back & "Nib" Back
Carpet Backing*

12 oz AEROSOL	CAN	6 CANS	12 (CASE)
	14.80	12.80	10.80

GLUE GUIDE

	TYPE	PAGE	FOAM TO FOAM	FOAM TO WOOD	FOAM TO METAL	LANDAU CAR TOP	CAR HEAD LINER	VINYL TO WOOD	VINYL TO METAL	FIBER TO FOAM	SET UP TIME	CLEAN UP	FLAMMABLE
Dap Weldwood	Aerosol	98	••	••	••	••	••	•••	•••	••	FAST	3M 8984	YES
Sprayway Fast Tac 92	Aerosol	98	••	••	••	••	••	•••	•••	••	FAST	3M 8984	YES
Kwik-Spray 840/860	Aerosol	98	•••	•••	••	••	•	•••	•	•••	FAST	MIN-SPIRITS	YES
3M 8090	Aerosol	100	•	•	••	••	••	•••	•••	•	FAST	3M 8984	YES
K-Grip 201	Bulk	99	•••	•••	•••	•••	•	•	•	•••	MED	K-Grip 200	NO
K-Grip 202 High Heat	Bulk	100	••	••	••	••	••	•	•	••	MED	K-Grip 200	NO
K-Grip Premium 203	Bulk	99	•••	•••	•••	•••	•	•	•	•••	MED	K-Grip 200	NO
Kwik-Spray 220	Bulk	99	•••	•••	•••	•••	•	•	•	•••	MED	KwikSpray 205	NO
Kwik-Spray 225	Bulk	99	•••	•••	•••	•••	•	•	•	•••	MED	KwikSpray 205	NO
3 Fastbond 100	Bulk	99	•••	•••	•••	•••	•••	•••	•••	•••	SLOW	WATER	NO
Weldwood	Bulk	100	••	•	•••	•••	••	•••	•••	•••	MED	3M 8984	YES
3M Fast Tack	Tube	100	•••	•••	•••	•••	•••	•••	•••	•••	FAST	3M 8984	YES
Vinyl Liquid Patch	Tube	101	Vinyl to vinyl: For Tears - Rips - Seams										
HH-66 Vinyl Cement	Brush Top	101	Vinyl to vinyl: For Where a Patch is needed.										
Premier Wood Epoxy	Tube	102	Bonds woods, & most materials. Stainable, adheres, fills, & fabricates. Fifteen (15) minute set.										
CA Adhesives	Bottle	102	Anything to anything. "Crazy Glue" type of adhesive. Fast Set up time.										
Platinum Web Spray	Aerosol	102	"Snap" Back & "Nib" Back carpet backing. Excellent for foam to foam.										

••• Best
•• Good
• OK

THE 118 K-GUN

- o A greatly refined glue gun
- o Optional glass jar
- o Siphon type external mix
- o Strong liquid nozzle
- o Easy to clean and maintain
- o Runs on 35-80 psi.
- o Adjustable tip

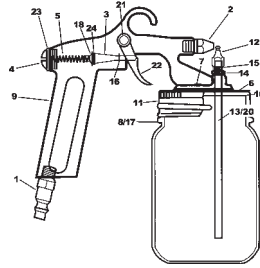

REF. PART#	DESCRIPTION	EACH
1	70606 Air inlet union	8.90
2	21038 Air nozzle	13.10
3	20950 Air valve ass'bly	15.70
4	20918 Air valve cap	11.70
5	20708 Air valve spring	3.80
6	20215 Cover plate	9.70
7	60103 Cover plate screw	.40
8	20223 Glass jar DISCONTINUED	
9	20107 Gun body	56.90
10	21525 Jar gasket	4.30
11	20240 Jar ring	4.50

REF. PART#	DESCRIPTION	EACH
12	20621 Liquid nozzle	16.60
13	20217 Liquid tube	13.00
14	20220 Locknut	5.70
15	20710 Nozzle spring	8.40
16	21518 Packing	1.60
17	20777 Plastic jar	7.60
18	31007 Retainng washer	3.60
21	61401 Swivel pin	.70
22	20406 Trigger	2.40
23	21542 Valve cap gasket	3.60
24	31009 Valve disk	3.10

THE ORIGINAL WEBSTER SPRAY GUN -
WELL KNOWN FOR MANY YEARS



PER SPRAY GUN **108.50**
REPAIR KIT #20310 (Contains: 10, 12, 13, 14, & 15) **33.50**

"EZE" SPRAY GUN

- o Durable Uni-Body design
- o Siphon type external mix
- o Cast aluminum body
- o Brass fittings
- o Stainless steel pickup tube
- o Runs on 35-80 psi.
- o Collar controlled adjuster

THE NEW "EZE" SPRAY GUN!

TOP QUALITY
CONSTRUCTION



SPRAY GUN PARTS

REF.	DESCRIPTION	EACH
1	Air Tip	3.00
2	Glue Tip/Filler Tube	12.00
3	Cup Gasket	2.50
4	Heavy Duty Plastic Jar	7.50
5	Heavy Duty Aluminum Jar	8.50



PER SPRAY GUN

57.00

HIGH PRESSURE SPRAY GUN

- o High quality construction
- o Full adjustable pattern control
- o Maximum trigger control
- o Non-bleeder siphon feed
- o External mix for fine atomization

PROFESSIONAL QUALITY!

*A cost effective spray gun providing
professional results.*

*The adjustable
wide web spray pattern;
great for applying
foam to foam adhesive
with just a
few passes!*



GREAT FOR APPLYING AUTO TOP & TRIM ADHESIVE!

PER SPRAY GUN

79.90

RE-COIL HOSE



Length: 25 Ft
Tips: Male/Female
1/4" IPT

Premium Urethane: Blue 89.40
Nylon Hose: Yellow 66.90

Urethane Hose
125 psi Operating pressure
500 psi Burst pressure

STRAIGHT HOSE



Length: 25 Ft
Tips: Male/Female
1/4" IPT

Per Hose 108.10

PIG TAIL HOSE



Length: 12 inches Tips: Male/Female 1/4" IPT

Per Hose 33.10

BLO- GUN



Per Gun 39.70

MALE COUPLER PLUG



Milton 727 1/4" NPT

Per Plug EACH 5.00

FEMALE COUPLER PLUG



Milton 728 1/4" NPT

Per Plug EACH 5.10

KWIK CHANGE COUPLER



Milton 711

Per Coupler EACH 20.90

SUREBONDER HOTMELT GLUE GUN

- High Temperature Trigger-Fed Glue Gun
- 2 Solid State PTC Heaters



HE-750 SUREBONDER
TIP PACK (3)



Shoots standard glue sticks. See Page 103

EACH 54.50
29.70

80 Watts of Power

Before you buy your next glue gun, find out why you are frustrated with your 40 watt and 20 watt guns.

Step up in power so it does not slow you down.

NOZZLES

3 Piece Set

TYPE



FLAT

3/4" Spread
1/4" Orifice



EXTENSION

3/4" Extension
1/8" Orifice



NEEDLE

3/4" Needle
5/64" Orifice

PLASTIC & LEATHER CLEANER 990

PROTECTS ORIGINAL FINISH - WITH OIL OF MINK

An excellent cleaner for all vinyls, leathers and plastics. conditions as it cleans. Adds new life to older vinyls and leathers. Contains lanolin to restore original softness. Contains no silicone.

	CAN	DOZEN
15 OZ AEROSOL	13.80	11.80



SOLVENT CLEANER & DE-GREASER C-60

REMOVES GREASE, DIRT, OIL & FRESH PAINT INSTANTLY

Cleans and degreases metals, painted surfaces, rubbers, fabrics, and plastics (except polystyrene). Also can be used on motors and generators.

	CAN	DOZEN
16 OZ AEROSOL	21.40	19.40



FURNITURE POLISH 811

BRINGS OUT THE HIDDEN BEAUTY - WITH LEMON OIL

Dusts, cleans and waxes. Leaves a hard, dust free surface. For light and dark furniture, plastic counters and table tops, ceramic and plastic tile, leather articles, chrome, stainless steel, porcelain, brass, marble, vinyl and enameled surfaces.

	CAN	DOZEN
19 OZ AEROSOL	15.00	13.00



VINYL CLEANER

- Water based
- All purpose
- Pump spray

SPECIFICALLY DESIGNED FOR VINYL

*Designed not to harm vinyl finishes!
Stays wet longer for deep cleaning!*

	BOTTLE	SIX
22 OZ PUMP SPRAY	21.50	19.00
	GALLON	4 GAL
GALLONS	59.50	54.50



FABRIC CLEANER 558

CLEANS VELOUR, CLOTH, CARPET, & UPHOLSTERY

Gently foams away soil, dirt, and grime without soaking into the fabric. Leaves surfaces clean and dry. With easy to use inverted spray nozzle.

Note: Not for use on suede or leather.

	CAN	DOZEN
19 OZ AEROSOL	16.00	12.90



CYPRESS SILICONE GLIDE

Glide is a nontoxic, non-oily scientifically formulated silicone spray which acts as a lubricant, reduces friction and sticking, repels moisture, and prevents corrosion. Glide will not cause discoloration or otherwise damage fabric. Treatment with Glide will reduce wear and give smoother operation. Glide will protect and preserve rubber and plastic.

	CAN	DOZEN	3 DOZEN
10.5 OZ. AEROSOL CANS	20.40	17.50	15.80



KWIK-SPRAY #440 UPHOLSTERY SILICONE

This light duty, medium viscosity silicone product is formulated specifically for UPHOLSTERERS. The #440 Silicone's characteristics provide excellent lubrication to aid in cushion stuffing by reducing friction without the build up of heavier silicones. Used to reduce friction on cutting tables, sewing needles, knives and cutters. Protects and restores any rubber, plastic and vinyl parts with periodic coatings, plus no ozone depleting chlorinated solvents!

	CAN	6 CAN	DOZEN
11 OZ. AEROSOL	16.00	14.50	13.50



HIGH TECH FABRIC GUARD 303

303 Fabric Guard is an easy to apply fluorocarbon based re-treatment product ideal for all natural and synthetic fabrics. Exhibits superior water and staining repellency and contains a UV screening agent to retard fading and degradation. Maintaining an outdoor fabric's repellency with 303 Fabric Guard will eliminate or minimize mildew problems. Goes much farther than silicone based treatments, providing up to 3 years of protection outlasting other products.

	EACH	DOZEN
16 OZ. TRIGGER SPRAYER	44.10	38.60



The ONLY repellency treatment recommended by and for: **sunbrella**



- Can Be Used On:**
- Acrylic Awnings
 - Outdoor Furniture
 - Boat & Sail Covers
 - Biminis & Enclosures
- Can Be Used For:**
- Water Repellency
 - Stain Resistance
 - UV Screening

AQUA-TITE GREEN

An eco-friendly green & clean technology product
PREMIUM GRADE DUAL-ACTION WATER & STAIN REPELLENT

AQUA-TITE, containing silicone, is a premium grade heavy duty water repellent solution. It restores the water repellency of cotton and synthetic fabrics. It can be used on flame resistant fabrics without affecting flame resistant properties. Its neutral color is suitable for use on all colors, however it may impart a slightly darker, richer tone to some lighter fabrics. One gallon properly covers approximately 500-700 square feet, depending on the absorbency of the fabric. Can be sprayed, brushed, or rolled. Quart comes with premium spray trigger applicator.

	QUART	GALLON
PER EACH	61.60	184.30

- Can Be Used On:**
- Acrylic
 - Polyester
 - Poly/Cotton Blends
 - Nylon
 - Leather & Canvas



Recommended For:
TOP GUN

NO FRAY SPRAY: 821 "Anti-Fraying" - Prevents Seam Slippage

No Fray Spray speeds workroom productivity while preventing unraveling of fabric and tapes during sewing operation. It also reduces seam failure, prevents thread slippage, and saves on sewing time by eliminating costly over stitching. It is transparent and will not stain when used as directed.

	CAN	DOZEN
10½oz AEROSOL	20.90	18.90



BeA BRAND #71 SERIES

ITEM#	SIZE	M/BOX	BX/CS	M/CS	BOX	4 BOX	CASE	2 CASES
71/4	5/32"	20	24	480	17.70	15.70	14.20	13.20
71/5	3/16"	20	24	480	17.70	15.70	14.20	13.20
71/6	1/4"	20	18	360	17.70	15.70	14.20	13.20
71/8	5/16"	20	12	280	18.60	16.60	15.10	14.10
71/10	3/8"	20	12	240	20.60	18.60	17.10	16.10
71/12	1/2"	20	12	240	22.80	20.80	19.30	18.30
71/14	9/16"	20	8	160	25.30	23.30	21.80	20.80

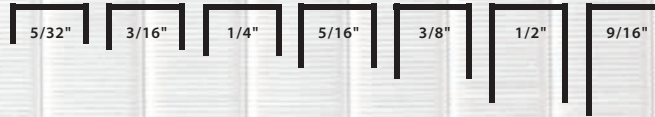

CROWN: $\frac{3}{8}$ "
WIRE: .02 x .03

BeA BRAND #80 SERIES

ITEM#	SIZE	M/BOX	BX/CS	M/CS	BOX	4 BOX	CASE	2 CASES
80/06	1/4"	24	8	192	32.00	30.00	28.50	27.50
80/08	5/16"	21	8	168	32.50	30.50	29.00	28.00
80/10	3/8"	18	8	144	31.00	29.00	27.50	26.50
80/12	1/2"	15	8	120	30.20	28.20	26.70	25.70
80/14	9/16"	15	8	120	33.70	31.70	30.20	29.20



WIDE CROWN

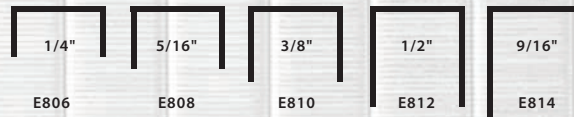

CROWN: 1/2"
WIRE: .036 x .028

FASCO BRAND #31 SERIES

ITEM#	SIZE	M/BOX	BX/CS	M/CS	BOX	4 BOX	CASE	2 CASES
#3108	1/4"	23,380	20	467	43.20	42.40	40.40	38.60
#3112	3/8"	16,700	20	334	20.40	19.60	17.60	16.90
#3116	1/2"	13,360	20	267	19.20	18.40	16.40	15.60
#3118	9/16"	13,360	20	267	24.20	23.40	21.40	20.50



CROWN: $\frac{3}{8}$ "
WIRE: .022

FASCO BRAND #33 SERIES

ITEM#	SIZE	M/BOX	BX/CS	M/CS	BOX	4 BOX	CASE	2 CASES
#336	3/16"	10	20		13.20	11.60	10.60	10.40
#338	1/4"	10	20		16.80	15.80	14.00	13.40
#3310	5/16"	10	20		17.80	16.80	14.80	14.20
#3312	3/8"	10	20		19.80	18.80	16.80	16.20
#3316	1/2"	10	20		21.40	20.40	18.40	17.60
#3318	9/16"	10	20		21.80	20.80	18.80	18.20

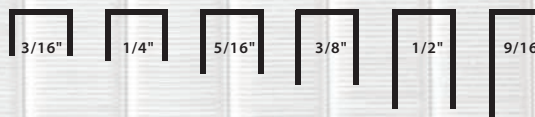

CROWN: 5/16"
WIRE: .026 x .030

IMPORT STAPLES COMPATIBLE TO FIT **BeA #71, Senco S3G, EMPIRE #7**

ITEM#	SIZE	M/BOX	BX/CS	M/CS	BOX	4 BOX	CASE	2 CASES
71/04	5/32"	10	20	200	13.60	12.60	10.60	10.20
71/05	3/16"	10	20	200	13.60	12.60	10.80	10.20
71/06	1/4"	10	20	200	13.80	12.80	10.80	10.40
71/08	5/16"	10	20	200	14.60	13.60	11.80	11.20
71/10	3/8"	10	20	200	15.60	14.60	12.60	12.20
71/11	7/16"	10	20	200	16.80	15.80	14.00	13.40
71/12	1/2"	10	20	200	17.40	16.40	14.40	14.00
71/14	9/16"	10	20	200	18.80	17.80	15.80	15.20



CROWN: $\frac{3}{8}$ "
WIRE: .02 x .03

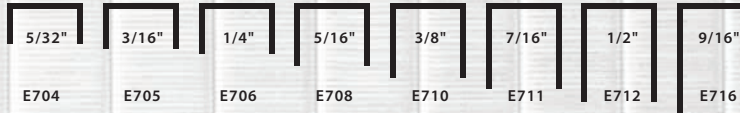

E704 E705 E706 E708 E710 E711 E712 E716

FASCO BRAND #71 SERIES

ITEM#	SIZE	M/BOX	BX/CS	M/CS	BOX	4 BOX	CASE	2 CASES
C02	5/32"	10	20	200	12.60	11.60	9.80	9.20
C03	3/16"	10	20	200	12.60	11.60	9.80	9.20
C04	1/4"	10	20	200	12.80	11.80	9.80	9.40
C05	5/16"	10	20	200	13.60	12.60	10.80	10.20
C06	3/8"	10	20	200	14.40	13.40	11.60	11.00
C07	7/16"	10	20	200	15.60	14.60	12.80	12.20
C08	1/2"	10	20	200	16.20	15.20	13.20	12.60
C09	9/16"	10	20	200	17.40	16.40	14.40	13.80



CROWN: $\frac{3}{8}$ "
WIRE: .02 x .03

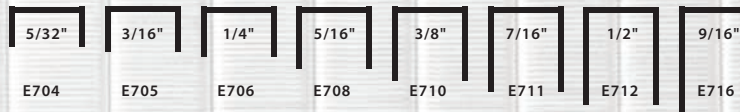

E704 E705 E706 E708 E710 E711 E712 E716

FASCO STAPLES #50 SERIES

ITEM#	SIZE	M/BOX	BX/CS	M/CS	BOX	4 BOX	CASE	2 CASES
508	1/4"	5	20	100	11.60	10.60	8.80	8.40
5012	3/8"	5	20	100	14.80	13.80	12.00	11.40
5016	1/2"	5	20	100	17.20	16.20	14.20	13.60
5018	9/16"	5	20	100	17.40	16.40	14.60	14.00



CROWN: 1/2"
WIRE: .02 x .05



FASCO BRAND #80 SERIES

ITEM#	SIZE	M/BOX	BX/CS	M/CS	BOX	4 BOX	CASE	2 CASES
E8006	1/4"	10	30	100	19.40	18.40	16.40	15.80
E8008	5/16"	10	24	240	20.40	19.40	17.40	16.80
E8010	3/8"	10	18	180	20.60	19.60	17.60	17.00
E8012	1/2"	10	16	160	23.20	22.20	20.20	19.60
E8014	9/16"	10	12	120	26.60	25.60	23.40	22.80



CROWN: 1/2"
WIRE: .036 x .028

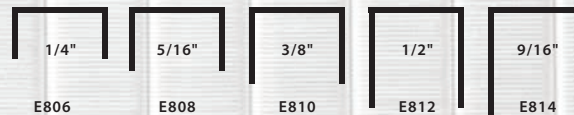

E806 E808 E810 E812 E814

IMPORT STAPLES COMPATIBLE TO FIT HAUBOLD 1400

ITEM#	SIZE	M/BOX	BX/CS	M/CS	BOX	4 BOX	CASE	2 CASES
1406	1/4"	10	20	200	14.80	13.80	12.00	11.40
1408	5/16"	10	20	200	16.60	15.60	13.60	13.20
1410	3/8"	10	20	200	16.80	15.80	13.80	13.20
1412	1/2"	10	20	200	19.00	18.00	16.00	15.40
1414	9/16"	10	20	200	20.00	19.00	17.00	16.40

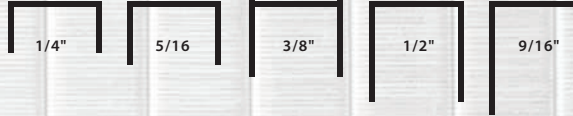

CROWN: 13/32"
WIRE: .023 x .027

FASCO STAPLES COMPATIBLE TO FIT SENCO #GO

ITEM#	SIZE	M/BOX	BX/CS	M/CS	BOX	4 BOX	CASE
GO4	1/4"	10	20	200	53.00	47.00	42.20
GO6	3/8"	5	40	200	58.80	52.20	47.00

CROWN: 3/8"
WIRE: .045 x .023
Galvanized



HEAVY WIRE

FASCO #9 STAPLES

FASCO	Style	Size	PER Box	Box
FASCO	#910	3/8"	10M	27.20
FASCO	#912	1/2"	10M	30.00



CROWN: 7/32"
WIRE: .021 x .030



STAINLESS STEEL STAPLES



FASCO	COMPATIBLE TO FIT	BeA #71	
STYLE	SIZE	PER BOX	BOX
71/04	1/4"	10M	52.00
71/10	3/8"	10M	58.20
71/12	1/2"	10M	63.80



BeA BRAND #71 Series			
STYLE	SIZE	PER BOX	BOX
71/04	1/4"	10M	54.00
71/10	3/8"	10M	55.40
71/12	1/2"	10M	58.20



BeA BRAND #80 Series			
STYLE	SIZE	PER BOX	BOX
80/06	1/4"	10M	58.10
80/10	3/8"	20M	140.90
80/12	1/2"	15M	117.00



FASCO	COMPATIBLE TO FIT	BeA #80	
STYLE	SIZE	PER BOX	BOX
80/04	1/4"	10M	101.60
80/10	3/8"	10M	123.20
80/12	1/2"	10M	131.00



FASCO	COMPATIBLE TO FIT	DuoFAST	
STYLE	SIZE	PER BOX	BOX
#3108	1/4"	10M	91.00
#3112	3/8"	10M	85.60



FASCO	COMPATIBLE TO FIT	DuoFAST	
STYLE	SIZE	PER BOX	BOX
#508	1/4"	5M	57.80
#5012	3/8"	5M	68.20
#5016	1/2"	5M	91.20



For Marine Applications
And Where
Moisture & Humidity
Can Rust Standard Staples



FASCO	COMPATIBLE TO FIT	HAUBOLD	
STYLE	SIZE	PER BOX	BOX
#1410	3/8"	10M	92.40



FASCO	COMPATIBLE TO FIT	SENCO	
STYLE	SIZE	PER BOX	BOX
#C04	1/4"	10M	55.40
#C06	3/8"	10M	61.80
#C08	1/2"	10M	68.00

FASCO STAPLE GUNS

FASCO

1" Standard



- 1" Nose for easy visibility
- Quick magazine release
- Easy loading of staples
- Lubricant on page 145

	PART #	CROWN	EACH
Senco CO	F1B-7C-16	11/32"	338.00
BeA #71	F1B-7C-16	11/32"	338.00
BeA #80	F1B-80-16	1/2"	338.00
Haubold #1400	F1B-14-16	13/32"	338.00
Duo-fast #3112	F1B-31-16	3/8"	338.00
Duo-fast #5012	F1B-50-16	1/2"	338.00

FASCO AUTO-MATIC

1" Standard

FASCO



- Shoots up to 1,660 per minute
- 1" Nose for easy visibility
- Full variable speed control
- Single shot lever
- Quick magazine release
- Easy loading of staples

	NOSE	CROWN	EACH
Senco CO	1"	11/32	650.00
BeA #71	1"	11/32	650.00

FASCO GIMP GUNS

FASCO



- The right tool for the right job
- Quick magazine release
- Easy loading of staples
- Lubricant on page 149

	PART#	CROWN	EACH
Empire #9: NARROW	F1A-9-16	7/32	390.00

FASCO LONG-NOSE 2" Long Nose



FASCO

- 2" Nose for great visibility
- 2" Nose for great versatility
- Quick magazine release
- Easy loading of staples

	PART #	CROWN	EACH
Senco CO	F1A-16-NL50M	11/32	530.00
BeA #71	F1A-16-NL50M	11/32	530.00

FASCO PINNER GUNS

FASCO



- The right tool for the right job
- Quick magazine release
- Easy loading of staples
- Lengths: max: 1 1/4" min: 1/2"
- Lubricant on page 145

	PART#	GAUGE	EACH
Headless Pinner Gun	F20PGA31	18	690.00

BeA AIR STAPLE GUNS



Operates on
75-90 PSI



BeA Fasteners USA

	NOSE	CROWN	EACH
#71 Standard Tacker	7/16"	11/32	318.00
#71 Long Nose	2"	11/32	592.80
#80 Standard Tacker	7/16"	16/32	333.00
#80 Long Nose	2"	16/32	626.30

FASCO 18 GA. PINS

FASCO

STYLE	SIZE	BOXES/CASE	PER BOX
EB820P	3/4"	20	5M
EB825P	1"	16	5M

STYLE	SIZE	Box	10BOX	20BOX	40BOX
EB820P	3/4"	24.80	21.80	20.80	19.80
STYLE	Size	Box	5BOX	10BOX	16BOX
EB825P	1"	28.20	25.20	24.20	23.20

FASCO ELECTRIC GUN

FASCO

- SAFE INTERLOCKING TRIGGER
- REAR LOADING WITH BUILT-IN PUSHER
- 12' EXTENSION CORD
- GREAT FOR ON-SITE OR SMALL JOBS
- NOT RECOMMENDED FOR FULL-TIME USE



	NOSE	CROWN	EACH
Fasco #71:	1"	3/8"	398.00
Fasco #80:	1"	1/2"	398.00
Fasco #33:	1"	5/16"	438.00
Fasco #50:	1"	1/2"	398.00

BeA: FURNITURE FRAME & CLIP GUN



BeA

HEAVY WIRE STAPLER

CROWN: 7/16"
WIRE: 16 Gauge
GALVANIZED
COMPATIBLE WITH: SENCO N

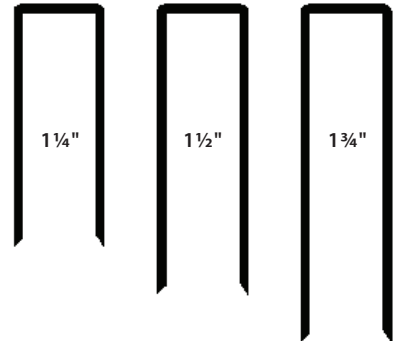

	CROWN	EACH	SIZE	ITEM#	BOX	BOX	4 BOX
BeA #14/50	7/16"	708.00	1 1/4"	16/32	5M	38.10	31.90
BeA #14 with SS Clip Kit	7/16"	1026.00	1 1/2"	16/38	5M	42.60	35.60
			1 3/4"	16/45	5M	58.70	49.00

BOSTITCH P-3

STANLEY BOSTITCH

*The most popular
Dacron stapler*

*Slim and light
for ease of use*



PER BOX	BOX	SIZE	CROWN	EACH	10 BX
	5M	1/4"	6/16"	10.00	8.00
P-3 HAND PLIER STAPLER					53.30

BOSTITCH B8P

STANLEY BOSTITCH

Uses "Power Crown" Staples
for extra driving power

Drives both 1/4" & 3/8" staples



SIZE	ITEM#	CROWN	BOX	EACH	10 BX
1/4"	STCR-2115	7/16"	5M	13.80	9.80
3/8"	STCR-2115	7/16"	5M	19.80	15.80
B8P HAND PLIER STAPLER					60.50

UPHOLSTERY TACKS

	Height	PCS/LB	1 LB	5 LBS	25 LBS
1½ oz. Tack	3/16"	4,590	87.30	426.50	
2 oz. Tack	4/16"	4,430	62.60	303.00	
2½ oz. Tack	5/16"	3,714	45.90	219.50	957.80
3 oz. Tack	6/16"	1,934	37.70	178.50	795.80
4 oz. Tack	7/16"	1,624	36.00	170.00	756.60
6 oz. Tack	8/16"	1,154	36.00	170.00	756.60
8 oz. Tack	9/16"	1,044	32.80	154.00	683.10
10 oz. Tack	10/16"	848	29.10	135.50	599.60

D.B. Gurney Co.

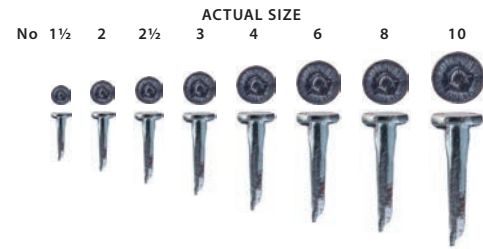

GIMP TACKS

	Height	PCS/LB	4 OZ	1 LB
4 oz. Tack	7/16"	2,500	26.80	97.00



D.B. Gurney Co.



WEBBING TACKS

	Height	PCS/LB	1 LB	5 LBS	25 LBS
12 oz. Tack	11/16"	527	28.50	132.50	584.50
14 oz. Tack	12/16"	486	28.50	132.50	584.50
16 oz. Tack	13/16"	475	28.50	132.50	584.50

D.B. Gurney Co.



WIRE BRADS



1 LB BOXES

	1 BOX	5 BOXES
1.25" x 16 GA	18.50	16.50
1.25" x 18 GA	18.50	16.50

SPRING -UP NAILS

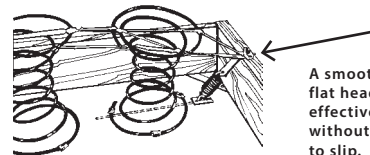

A smooth finished nail with a large flat head designed specifically to effectively anchor twine to a frame without cutting or allowing the twine to slip.

	PCS/Lb	POUND
7/8" x 13 Ga	549	15.30

PANEL NAILS

HEAD SIZE: ¾" DIAMETER



	PCS/LB	POUND	5 POUNDS
LENGTH: 7/8"	127	15.80	14.20
LENGTH: 1-1/8"	102	15.80	14.20
LENGTH: 1-3/4"	94	15.80	14.20

SPRING CLIP NAILS



	POUND	10 LB	25 LB
1" EK Barbed	14.60	11.60	10.90
1" Steel Webbing	14.60	11.60	10.90

VELVET EDGE TACKTITE WITH COVERS



Velvet edge
tack strip now
comes in a sleeve!

Velvet edge tack strips
Protect upholstery materials
Better than ever!

The softest touch
In tack strips
Just got softer!

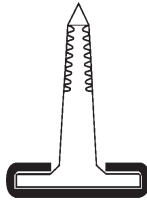

You now have the option of getting a plastic cover with Your favorite Tack Tite

- Now the most delicate fabrics and leathers are protected during upholstery and shipment. Handy's rounded edge, Velvet Edge Tack Strips, have always been gentle on fabrics.

- Slim, "soft touch" Velvet Edge Tack Strips are now available with smooth plastic sleeves, they protect better than ever. These sleeves are locked in place on the tack strip to prevent slipping resulting in seams that have a smoother, hand-tailored look with less chance of damage to upholstery materials.

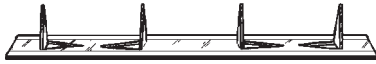

TACK	LENGTH	100	500	1000	
10	30"	117.30	107.30	101.30	PER 100

TACK STRIP COVERS



30" LENGTHS 1,000 FOOT ROLL	EACH	100 PIECES	500 PIECES
	1.26	.38	.34
	178.90		

VELVET EDGE TACKTITE

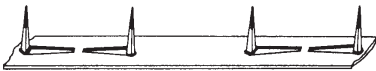

TACK	LENGTH	100	500	1000	
10	30"	86.80	75.00	71.40	PER 100
10	36"	109.80	94.80	90.20	PER 100
10	54"	146.60	128.20	120.60	PER 100

METAL TACK STRIP



TACK	LENGTH	100	500	1000	
8	30"	131.20	112.90	105.70	PER 100
10	30"	131.20	112.90	105.70	PER 100

PANEL CHIPBOARD

A HEAVY WEIGHT PANEL BOARD

Interior Panel Supports - Heavy Duty
Inside / Outside - Arms & Backs

Sheet Size: 36" x 48"
Per Pack: 20 Sheets



Thickness: .060"
Weight / Pc: 2Lbs 4oz

PER 36" x 48" SHEET	SHEET	20 SHT	40 SHT	60 SHT
	7.46	5.66	5.46	5.26

"HANDY" FLEX-TRIM / PLI-GRIP

Flex-trim is a continuous strip invisible fastener flexible enough to conform smoothly to twists, bends and radical curves without hand sewing. It won't buckle even when twisted and curved at the same time. No more sewing, double welting or gimp tacks. Simply cut off the length you want, when you want it. Galvanized satin finish to prevent rusting and staining.



Available either in two or three tooth Regular or Heavy.

100' COILS

	WT/CS	TYPE	REEL	CASE	3 CASE	
"Regular"	16 lbs	3 Tooth	29.90	25.90	24.10	Priced Per Reel
"Heavy"	20 lbs	3 Tooth	33.90	29.90	27.90	5 Reels Per Case

FLEX TRIM PADDING

- Helps pad and prevent thin fabrics from being cut or frayed
- Helps pad metal edges from giving an uneven appearance
- Gives a smooth and finished edge

URETHANE FOAM PADDING
with SELF ADHESIVE

APPLIES TO OUTSIDE EDGE
of METAL EDGING

1/8" x 3/4" x 100' Rolls

ROLL 28.30
4 ROLL 26.30

CARDBOARD TACKING STRIP

	WD	THICK	DIA	FT/RL	WT/RL
Economy Plus	1/2"	.040	15 3/4"	375	2.20
Regular Economy	3/8"	.032	17 1/4"	415	2.15

WD	TYPE	ROLL	6 PACK	12 PACK	CASE	RLS/CS
3/8"	ECONOMY PLUS	10.50	8.00	7.00	6.50	(37)
1/2"	ECONOMY PLUS	12.60	10.10	9.10	8.60	(27)
3/4"	ECONOMY PLUS	16.90	14.40	13.40	12.90	(18)



CARDBOARD TACK STRIPS

STRAIGHT 38" STRIPS

THICKER THAN ROLL STOCK

	Thickness
Cut-Strips	.050"
Economy Plus	.040"

1/2" x 38" PER POUND

10 LBS 6.10
50 LBS 4.50



X-HARD TACKING STRIP

"Extra Tough"

	WD	THICK	DIA	FT/RL	WT/RL
Extra Hard	1/2"	.050	15 7/8"	285	3.25

WD	TYPE	ROLL	6 PACK	12 PACK	CASE	RLS/CS
3/8"	Extra-HARD	16.10	13.60	12.60	12.10	33
1/2"	Extra-HARD	19.00	16.50	15.50	15.00	27
3/4"	Extra-HARD	26.50	24.00	23.00	22.50	18



3 1/4 Lb Rolls

MARINE BLIND 1/2" TACKING STRIP - NYLON

100% NYLON - CLEAR
Will not soil, rust, or lose shape.

Roll Size: 1/2" x 500'
Pack Type: Flat Pancake

Thickness: .031"
Weight / Pc: 2Lbs 6oz

PER ROLL
50' RL 49.00
500' RL 290.00

DECORATIVE NAILS

ACTUAL SIZES SHOWN

FRENCH NATURAL



STYLE	1009	1010	1012	1019	1037	1043	1620
SHANK	1/2", 3/4"	1/2"	1/2"	1/2"	1/2"	1/2"	5/8"
PCS/BX	1000	1000	1000	1000	300	1000	100
PRICE	37.80, 41.60	36.30	34.30	49.10	100.70	42.00	110.00

FRENCH NATURAL



STYLE	1054	1052	1050
SHANK	5/8"	5/8"	5/8"
PCS/BX	500	200	150
PRICE	93.80	65.60	83.30

REGAL



STYLE	1009	1010
SHANK	1/2"	1/2"
PCS/BX	1000	1000
PRICE	49.00	52.60

FRENCH NATURAL LIGHT

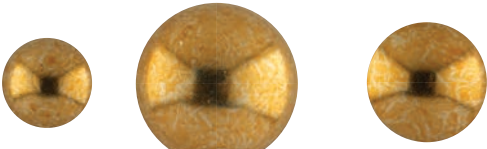

STYLE	1009	1052	1054
SHANK	1/2"	3/4"	5/8"
PCS/BX	1000	200	500
PRICE	39.80	65.60	93.80

FRENCH NATURAL DARK



STYLE	1009	1054
SHANK	1/2"	5/8"
PCS/BX	1000	500
PRICE	39.80	93.80

FRENCH NATURAL ANTIQUE



STYLE	1009	1037	1052	1054
SHANK	1/2"	5/8"	3/4"	5/8"
PCS/BX	1000	300	200	500
PRICE	39.80	100.70	65.60	93.80

NATURAL



STYLE	1009	1010	1037	1043	1050	1052	1054
SHANK	1/2", 3/4"	1/2"	1/2"	1/2"	5/8"	5/8"	5/8"
PCS/BX	1000	1000	300	1000	150	200	500
PRICE	37.80, 41.60	36.30	100.70	42.00	83.30	65.60	93.80

DECORATIVE NAILS

ACTUAL SIZES SHOWN

NATURAL DARK



STYLE 1009
SHANK 1/2"
PCS/BX 1000
PRICE 39.80



STYLE 1037
SHANK 5/8"
PCS/BX 300
PRICE 100.70



STYLE 1052
SHANK 5/8"
PCS/BX 200
PRICE 65.60

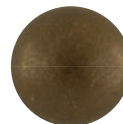

STYLE 1054
SHANK 5/8"
PCS/BX 500
PRICE 93.80

BLACK GLOSS



STYLE 1009
SHANK 1/2"
PCS/BX 1000
PRICE 55.60



STYLE 1054
SHANK 5/8"
PCS/BX 500
PRICE 109.60

BLACK FLAT



STYLE 1009
SHANK 1/2"
PCS/BX 1000
PRICE 55.60



STYLE 1052
SHANK 5/8"
PCS/BX 200
PRICE 71.40



STYLE 1054
SHANK 5/8"
PCS/BX 500
PRICE 109.60

BLACK NICKLE



STYLE 1009
SHANK 1/2"
PCS/BX 1000
PRICE 55.60

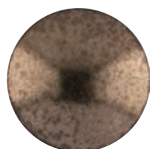

STYLE 1037
SHANK 5/8"
PCS/BX 300
PRICE 115.60

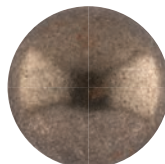

STYLE 1052
SHANK 5/8"
PCS/BX 200
PRICE 71.40



STYLE 1054
SHANK 5/8"
PCS/BX 500
PRICE 109.60

BLACK "Z"



STYLE 1009
SHANK 1/2"
PCS/BX 1000
PRICE 62.10

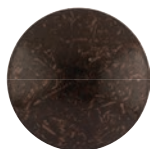

STYLE 1037
SHANK 5/8"
PCS/BX 300
PRICE 127.40

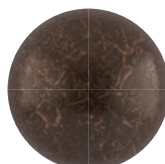

STYLE 1052
SHANK 5/8"
PCS/BX 200
PRICE 80.70



STYLE 1054
SHANK 5/8"
PCS/BX 500
PRICE 123.00

PEARL BLACK



STYLE 1009
SHANK 1/2"
PCS/BX 1000
PRICE 55.90



STYLE 1010
SHANK 1/2"
PCS/BX 1000
PRICE 50.80



STYLE 1043
SHANK 1/2"
PCS/BX 1000
PRICE 46.70

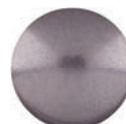

STYLE 1054
SHANK 5/8"
PCS/BX 500
PRICE 100.30

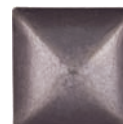

STYLE 1620
SHANK 5/8"
PCS/BX 100
PRICE 114.00

NAIL HEAD DIAMETER CHART *BY SIZE*

DIAMETER	8/32"	9/32"	10/32"	11/32"	13/32"	14/32"	15/32"	16/32"	20/32"	21/32"	23/32"	24/32"	27/32"	31/32"
STYLE	1019	1012	1043	1990	1010 1910	1560 1963	1009 1909 36 1533 1535	31 1538 1626	1054 32 1620	1038 1920	1610	1037 1622	1052	1050

DECORATIVE NAIL TOOLS



No. 777



No. 601

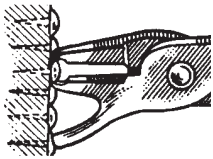

No. 6750

Specifically for 1009 Style Nail Heads
Lightweight Ergonomic Design 11lb, 6oz
Single Nail Design, Will Never Jam the Tool
Magnetized Barrel Loads Nails Effortlessly
Recommended Air Pressure: 60-80 PSI

No. 601 Antique Nail Puller
No. 777 Quick Nailer: Aligner/Spacer
No. 6750 Pneumatic Nailer w/Loading Board
Additional Loading Boards

EACH
66.60
17.20
419.60
66.30

OLD GOLD ANTIQUE



STYLE 1009
SHANK 1/2"
PCS/BX 1000
PRICE 52.40

GILT



STYLE	1043	1050	1052	1054
SHANK	1/2"	5/8"	5/8"	5/8"
PCS/BX	1000	150	200	500
PRICE	43.60	85.10	68.00	93.80

DECORATIVE NAILS

ACTUAL SIZES SHOWN

GILT



STYLE	1006	1009	1010	1012	1019	1037	1038
SHANK	7/16"	1/2"	1/2"	1/2"	1/2"	1/2"	1/2"
PCS/BX	1000	1000	1000	1000	1000	300	400
PRICE	72.00	37.80	36.30	34.30	49.10	102.00	138.90

GILT



STYLE	36	1533	1560	1610	1626	1909H	1990H
SHANK	1/2"	1/2"	1/2"	1/2"	1/2"	1/2"	1/2"
PCS/BX	500	1000	1000	100	100	1000	1000
PRICE	127.00	49.90	46.40	104.80	65.40	41.60	53.50

NICKEL



STYLE	1009	1010	1012	1019	1043	1054	1533	1909H
SHANK	1/2", 3/4"	1/2"	1/2"	1/2"	1/2"	5/8"	1/2"	1/2"
PCS/BX	1000	1000	1000	1000	1000	500	1000	1000
PRICE	39.10, 41.60	37.40	34.30	49.10	45.10	89.00	49.90	41.60

OLD SILVER



STYLE	1009	1010	1037	1038	1052	1054	1920
SHANK	1/2"	1/2"	1/2"	1/2"	5/8"	5/8"	1/2"
PCS/BX	1000	1000	300	400	200	500	200
PRICE	59.50	48.30	115.60	146.70	72.50	99.80	129.20

OLD SILVER



STYLE	1560	1620
SHANK	1/2"	5/8"
PCS/BX	1000	100
PRICE	53.50	123.50

GUNMETAL



STYLE	1009	1054
SHANK	1/2"	5/8"
PCS/BX	1000	500
PRICE	55.90	109.60

PEWTER



STYLE	1009	1054
SHANK	1/2"	5/8"
PCS/BX	1000	500
PRICE	53.20	100.10

QUANTITY DISCOUNTS
5 BOXES: 5% OFF
10 BOXES: 10% OFF

PRICES SUBJECT TO CHANGE WITHOUT NOTICE

COPPER PLATED



STYLE	1009	1054
SHANK	1/2"	5/8"
PCS/BX	1000	500
PRICE	43.10	103.30

OLD BRASS



STYLE	1009	1610
SHANK	1/2"	1/2"
PCS/BX	1000	100
PRICE	55.90	112.30

OXFORD



STYLE	1533	1535	1538	1963	1009H	1909H	1910H
SHANK	1/2"	1/2"	1/2"	1/2"	1/2"	1/2", 3/4"	1/2"
PCS/BX	1000	1000	500	1000	1000	1000	1000
PRICE	49.90	56.50	107.90	49.00	49.70	37.80, 41.00	47.70

OXFORD



STYLE	1052H	1054H
SHANK	5/8"	5/8"
PCS/BX	200	500
PRICE	106.30	133.50

Z FINISH



STYLE	1009	1010	1054
SHANK	1/2"	1/2"	5/8"
PCS/BX	1000	1000	500
PRICE	62.10	61.10	93.80

RELIEVED ANTIQUE

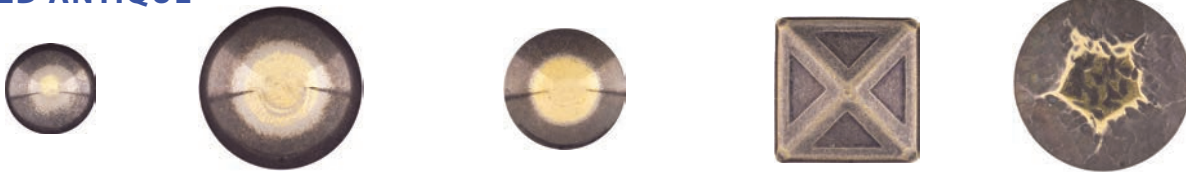

STYLE	1009	1052	1054	1622	1920
SHANK	1/2"	5/8"	5/8"	1/2"	1/2"
PCS/BX	1000	200	500	100	200
PRICE	83.20	74.50	126.00	114.30	130.60

DECORATIVE NAIL STRIP



STYLE	FINISH	YD/RL	1 ROLL	5 ROLL
1009	FR NATURAL	50	76.10	63.60
1009	NICKLE	50	86.60	78.20
NAILS TO MATCH		PER BOX	1 BOX	5 BOX
1009 - 1/2" Shank		1,000	42.30	38.10
1009 - 3/4" Shank		1,000	49.20	44.30

SOLID BRASS

the definitive antique restoration nail



STYLE	HEAD DIA/32 nd	SHANK LENGTH	PIECES PER BOX	FRENCH NATURAL	NATURAL	GILT
9	15	1/2"	1000	89.60	89.60	89.60
10	13	1/2"	1000	84.60	4.60	n/a

BUTTON COVERING SERVICE



*Send us the fabric -
We'll do the rest!*

One of the TRENDS in furniture is BIG BUTTONS. However, with big buttons, comes a big outlay of money for some very expensive dies and cutters. Secondly, although the trend is going towards these bigger buttons, only a minimum number of buttons are being used on a piece. Therefore, we are providing you with an economical solution; we will make them for you! Orders processed within 24 to 48 hours.



WIRE- EYES

SIZE	FIRST DOZEN	ADDITIONAL DOZENS
#22	25.60	17.60
#30	26.20	18.00
#36	26.60	18.40
#40	29.20	20.40
#45	30.60	21.40
#50	33.40	23.80
#60	38.80	27.60
#80	43.60	31.60
#48/65	43.00	31.00

PRONGS

SIZE	FIRST DOZEN	ADDITIONAL DOZENS
#22	27.00	19.00
#30	27.40	19.40
#36	29.00	20.60
#40	30.40	21.60
#45	31.00	22.20
#50	N/A	N/A
#60	N/A	N/A
#80	N/A	N/A
#48/65	N/A	N/A

NO-DENTS

SIZE	FIRST DOZEN	ADDITIONAL DOZENS
#22	28.20	19.80
#30	29.00	20.60
#36	30.80	22.00
#40	N/A	N/A
#45	33.80	24.20
#50	N/A	N/A
#60	N/A	N/A
#80	N/A	N/A
#48/65	N/A	N/A

FABRIC NEEDED PER BUTTON

SIZE	FABRIC NEEDED PER BUTTON
#22	1 1/4" x 1 1/4"
#30	1 1/2" x 1 1/2"
#36	1 5/8" x 1 5/8"
#40	1 7/8" x 1 7/8"
#45	2" x 2"
#50	2 1/4" x 2 1/4"
#60	2 3/8" x 2 3/8"
#80	3" x 3"
#48/65	2 3/8" x 2 3/8"



SINGLE PIVOTS

SIZE	FIRST DOZEN	ADDITIONAL DOZENS
#30	30.20	21.40
#36	32.80	23.20
#40	N/A	N/A
#45	39.20	28.00

JOINED PIVOTS

SIZE	FIRST DOZEN	ADDITIONAL DOZENS
#30	34.00	25.20
#36	36.60	27.00
#40	N/A	N/A
#45	N/A	N/A

1PC DURA SNAPS

SIZE	FIRST DOZEN	ADDITIONAL DOZENS
#30	28.80	20.00
#36	29.40	20.60
#40	N/A	N/A
#45	N/A	N/A

FABRIC NEEDED

SIZE	FABRIC NEEDED
#30	1 1/2" x 1 1/2"
#36	1 5/8" x 1 5/8"
#40	1 7/8" x 1 7/8"
#45	2" x 2"

DRAPERY GROMMETS: #12



- Made of heavy duty brass
- Ideal for curtains and draperies
- Cutters and dies work with Handy Junior

FINISH	SIZE	OD	I.D.	20/BOX
Gold	12	2 1/2"	1 9/16"	84.40
Nickel	12	2 1/2"	1 9/16"	84.40
Antique	12	2 1/2"	1 9/16"	84.40
Black	12	2 1/2"	1 9/16"	84.40

SIZE	EACH
#12 Die & Cutter	195.90

BUTTONS



STANDARD SHELL



SOFT SHELL



RUST RESISTANT



STANDARD EYE



SHORT EYE #44



PRONG MOLD

SHELLS

In 3 Types: Regular, Soft and Rust Resistant. Soft is recommended for heavy weight materials and naughahyde at no extra charge. Complete rust resisting moulds (shells and backs) are standard with many manufacturers because they minimize rusting problems resulting in damaged, costly upholstery. Standard rust resistance is zinc plated which is easily recognizable. The backs (i.e. WE's and prongs) are already rust resistant.

WIRE EYES

Wire Eyes are the industry's choice for twine tufting. The standard has a heavy eye and will withstand 80 lb. pullout tests. The 44 Short Eye has a smaller eye and is intended to be used against delicate materials to minimize piercing and runs. The standard wire eye is available upon request in the liplock or flare model at no extra charge.

PRONG SIZES: 1 1/2" 2" 2 1/2"

Prong button tufting is fast, economical and strong. It eliminates many operations common to twine tufting and requires no special skills or button dies. The prong is anchored firmly in place by bending the flatwire legs over a prong washer in back of the padding.

		GROSS	5 GROSS			GROSS	5 GROSS
22	Shell	7.00	4.20	40	Shell	11.20	8.40
22	RR Shell	9.00	6.20	40	RR Shell	14.20	11.40
22	Wire Eye	11.40	8.60	40	Wire Eye	20.40	17.60
22	1 1/2" Prong	23.60	20.00	40	2" Prong	35.80	33.00
22	2" Prong	27.00	23.40				
22	2 1/2" Prong	42.20	38.60				
				45	Shell	12.60	9.80
				45	RR Shell	15.60	12.80
24	Shell	7.80	5.00	45	Wire Eye	22.60	19.80
24	RR Shell	9.80	7.00	45	2" Prong	32.80	38.00
24	Wire Eye	13.20	10.40				
				50	Shell	18.20	15.40
				50	RR Shell	21.20	18.40
30	Shell	8.20	5.40	50	Wire Eye	32.80	30.00
30	RR Shell	10.40	7.60				
30	Wire Eye	13.60	10.80	60	Shell	21.20	18.40
30	1 1/2" Prong	28.60	25.00	60	RR Shell	26.60	23.80
30	2" Prong	32.20	28.60	60	Wire Eye	40.00	37.20
30	2 1/2" Prong	38.80	35.20				
36	Shell	9.20	6.40				
36	RR Shell	10.80	8.00	80	Shell	30.20	27.40
36	Wire Eye	15.20	12.40	80	RR Shell	41.40	38.60
36	1 1/2" Prong	31.00	27.40	80	Wire Eye	60.20	57.40
36	2" Prong	34.80	31.00				

THE BUTTON COVERING PROCESS

Button covering dies wrap material around the shell and crimp the shell over the sides of the back. Drawing A shows the fabric in place over the shell in the top die. Drawing B shows the fabric wrapped under the shell by die action as the top die plunger moves down toward the bottom die. Drawings C and D show the assembly and clinching of the fabric-wrapped shell against the back, making the button solid and secure.

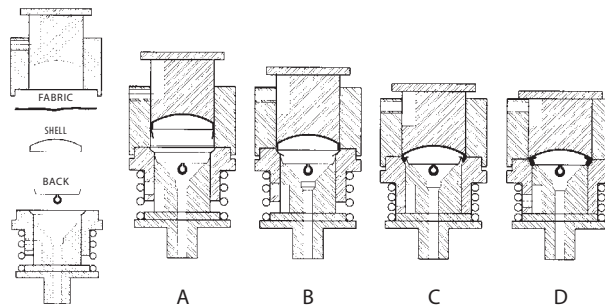

BUTTON SIZES

ACTUAL SIZES

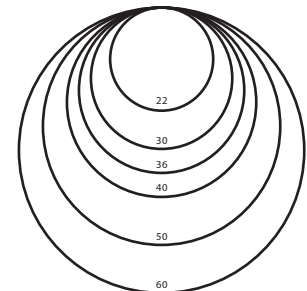

ALUMINUM BUTTON SHELLS & NYLON HOOK BUTTONS

The nylon hook is used just as you would a regular wire-eye. However, when used with an aluminum shell, you can prevent rust or discoloration in applications where moisture is a concern.

For marine, patio and everyday furniture!



	GROSS	5 GROSS		GROSS	5 GROSS
22 Shell	10.20	7.40	22 Hook	16.80	14.00
30 Shell	12.20	9.40	30 Hook	18.00	15.20
36 Shell	14.40	11.60	36 Hook	20.40	17.60

THREADED NAIL MOLDS

When anchored with a spring lock washer, the Threaded Nail is a fast, positive, alternative to prong tufting. Just insert the nail through the upholstered construction and fasten it on the back with a No. 15 Spring Washer. (for washers, see page 110)



Set includes Nail Mould and Shell

Set: Threaded Button Back, 1 Shell

	NAIL	GROSS	5 GROSS
No. 22 Standard Shell	-	9.00	6.20
No. 22 Thread Nail	2"	35.60	32.40

NO DENT-NAIL MOLDS

Heavy duty 13 gauge corrugated upholstery nails are welded to buttonbacks. The Nail-Molds can be driven through fabric and fastened directly to a frame. The back is stamped of heavy steel and formed to support the shell and prevent denting.



Set includes Nail Mould and Shell

	GROSS	5 GROSS		GROSS	5 GROSS
22 RR Shell	9.00	6.20	22 Nail	26.20	22.80
30 RR Shell	10.40	7.60	30 Nail	43.80	40.40
36 RR Shell	10.80	8.00	36 Nail	34.40	30.80
45 RR Shell	15.60	12.80	45 Nail	44.00	40.40

3/4" Nail

JOINED PIVOT MOLDS

STOCK PUT-UP WITH SOFT RUST RESISTANT SHELLS

Joined Pivot: Use on pillows and cushions where buttons are wanted on both sides. Easily held together by hand pressure. Serrated nail and spring steel washer hold buttons tight. The nail can be cut for shorter lengths.



Set Includes Back w/ Tack, Back and 2 Shells

	GROSS	5 GROSS		GROSS	5 GROSS
30 RR Shell	10.40	7.60	36 RR Shell	10.80	7.60
30 Back	29.00	25.40	36 Back	34.00	30.60
30 Back/tack	56.60	53.20	36 Back/Tack	56.60	53.20

1/2" Tack

SINGLE PIVOT MOLDS

Single Pivot: Female part of the Joined Pivot with separate serrated tacks to tailor skirts, etc. Using a Single Pivot is an ideal method when a button is required on only one side.

Set: Tack, Back, 1 Shell



Set Includes Tack, Back and Shell

	GROSS	5 GROSS		GROSS	5 GROSS		GROSS	5 GROSS
30 RR Shell	10.60	7.80	36 RR Shell	10.80	8.00	45 RR Shell	15.60	12.80
30 Back	24.80	21.40	36 Back	27.20	23.80	45 Back	40.40	37.60
30 Tack	9.00	5.40	36 Tack	9.00	5.60	45 Tack	9.20	5.60

BUTTON WASHERS

No. 1



Washer for pronged buttons

No. 15



Spring washer for threaded nails

	GROSS	5 GROSS BOX
Size No. 1	10.60	7.80
Size No. 15	19.60	16.80

#40 FINISHED HOOK BUTTONS

A weatherproof nylon button made to simulate an upholstered button.

Colors: White or Eggshell



eggshell shown

Per Each	EACH	50	144
	.44	.26	.18

ONE PIECE DURASNAPS

This economical nylon back is specially designed to snap onto a Durable Wood Screw or Durable Stud when covered. Cover the DuraSnap the regular way, screw the stud into the upholstered panel, and snap the covered DuraSnap over it. The DuraSnap provides a secure hold with little chance of rust or discoloration.

	GROSS	5 GROSS BOX
No. 30 Shell	8.20	5.40
No. 30 Ring	22.60	19.80
No. 36 Shell	9.20	6.40
No. 36 Ring	25.60	22.80



Stud not included

DURA-SNAP FASTENERS

100/BOX

TYPE	CHROME	GILT
	on BRASS	on BRASS
CAP	22.40	24.90
SOCKET	19.90	26.40
STUD	12.80	17.20
EYELET	11.70	18.40
SCREWSTUD 3/8"	42.40	-



Cap 670



Socket 548



Stud 550



Eyelet(Post) 550A



Screw Stud 457

For marine applications, use brass.
For more complete selections, see pages 219-221.

BRUSHED BRASS BUTTONS

The buttons are pre-assembled with a standard wire-eye back and a brushed, brass finish. Bright Gold and Nickel may be special ordered with a 5 gross minimum. Prong backs may also be special ordered.

	GROSS	5 GROSS BOX
No. 30 Wire Eye	55.80	52.80
No. 30 2 1/2" Prong	70.20	62.20



Brushed Brass Cap
Standard Wire Eye

VENTILATORS

BRASS



Size	OVERALL DIAMETER	SHANK DIA.	SHANK LENGTH
1	3/4"	9/16"	3/16"
2	1"	3/4"	19/64"

Brass Ventilators with a gold finish. These ventilators clinch permanently with or without washers. The bevelled under-edge fits smoothly and firmly to any ticking, plastic, or fabric.
An extra long shank can be special ordered:
No. 1 LS 1/4", No. 2 LS 11/32".

	Per Dozen	DOZEN	4 DOZEN
No. 1 Ventilator	8.60	7.80	
No. 1 Washer	4.00	3.00	
No. 2 Ventilator	12.40	11.40	
No. 2 Washer	3.80	3.00	

VENTILATOR DIES

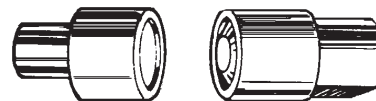

	EACH
#1 VENT. No. 621-3/4" HAND DIE	33.80
#1 VENT. No. 149-7/16" Vinyl Hole Punch	50.90
#1 VENT. No. 149-9/16" Leather Hole Punch	72.80
#2 VENT. No. 621-1" HAND DIE	36.30
#2 VENT. No. 149-5/8" Vinyl Hole Punch	70.70
#2 VENT. No. 149-3/4" Leather Hole Punch	74.40
#1 VENT. HANDY JUNIOR DIE	838.20
#2 VENT. HANDY JUNIOR DIE	930.40

BUTTON MACHINES



HANDY JUNIOR

- Production approximately 90 per hour.
- Versatile manually operated machine.
- Used with Handy 2-piece die.
- Can also operate grommet, dura-snap, & ventilator dies.



OSBORNE W-2 3-PIECE (SPECIAL ORDER)

- Production approximately 200 per hour.
- Used with 3-piece swivel dies that feed button material into top of die semi-automatically.



	EACH
Handy Junior-2 Piece Machine	341.60
Osborne W-2 3-Piece Machine	1,911.80
<i>Parts:</i>	
Handle For Button Machine	87.40
Top Disc	56.20
Plunger	91.40
Plunger Spring	52.20
Plunger Pin	9.60

BUTTON DIES

TWO PIECE DIES

Dies to be used with the junior button machine and come complete with a short cutter.

THREE PIECE DIES

To be used with various handy three piece machines and comes complete with a long cutter.

DIE WEIGHTS

We stock all the heavy dies in the most common sizes. The light and medium dies can be ordered at no extra charge. The different weights are intended for the different weights in fabric. The medium dies work with the majority of fabrics. If using a lot of naugahyde and having button making problems, a heavy die may help.

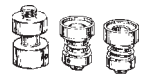

	2 PC DIE	3 PC DIE
No. 22	182.40	715.80
No. 24	200.40	780.60
No. 30	200.40	807.40
No. 36	218.20	890.00
No. 40	267.00	1056.00
No. 45	293.40	1116.80
No. 50	313.20	-
No. 60	360.20	1284.60
No. 80	-	1540.60

CUTTING BOARDS

Long-lasting, replaceable fiber cutting boards.



2 1/2" diameter blocks

Fibre Cutting Board	EACH
	10.80

CUTTERS

Sharp, hardened steel cutters are available in all sizes. A short cutter comes with a two piece die set, and a long cutter with the three piece set.

	SHORT	LONG
No. 22	85.00	120.80
No. 24	85.00	120.80
No. 30	85.00	125.00
No. 36	90.60	129.40
No. 40	102.80	137.60
No. 45	110.60	185.00
No. 50	138.60	219.00
No. 60	134.20	232.40
No. 80	241.80	401.00



VENT PUNCH



HOLE PATTERN

#622 VENTILATOR PUNCH	EACH
	104.60

BUTTON DRILLS

• The Osborne cutter is made to cut FOAM, VINYL, FABRIC, POLY, and other soft materials.

• Cutters have special carbonized hardened edges.

• Makes diamond tufting easy.

• Makes button circles fast and easy - up to 30 buttons at a time.

• Use with a drill press or a hand held drill.



SIZE	HOLE	EACH
22	1"	139.00
30	1-1/4"	139.00
36	1-7/16"	139.00
40	1-1/2"	139.00
Jig		51.10

WOOD LEGS

MEASUREMENT INFORMATION

HT = Height of Leg

Two Width Measurements are listed.
The First: Widest Measurement
The Second: Narrowest Measurement

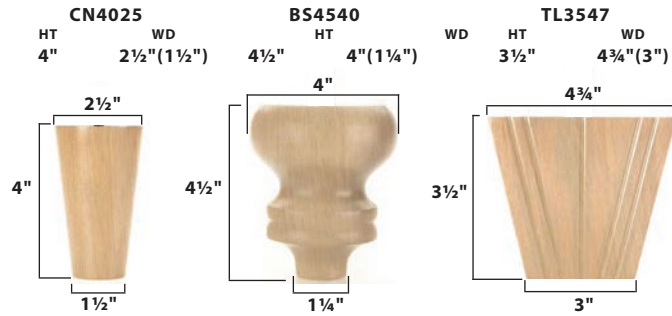

ALL
HANGER BOLTS
USE A
5/16" x 18
THREAD

CY1522		CY2022		CY2522		CY3022		CY4022		CY5022		CY6022	
HT	WD	HT	WD	HT	WD	HT	WD	HT	WD	HT	WD	HT	WD
1 1/2"	2 1/4"	2"	2 1/4"	2 1/2"	2 1/4"	3"	2 1/4"	4"	2 1/4"	5"	2 1/4"	6"	2 1/4"
WALNUT FINISH													
1	16	1	16	1	16	1	16	1	16	1	16	1	16
3.80	3.30	4.30	3.70	4.50	3.90	5.00	4.30	5.70	4.90	7.30	6.40	9.00	7.90

LP4025		LP5028		LP5035		LP6030		LP6010	
HT	WD	HT	WD	HT	WD	HT	WD	HT	WD
4"	2 1/2" (1 3/4")	5"	2 3/8" (1 5/8")	5"	3 1/2" (2 5/8")	6"	1" (2")	6"	1" (3/4")
1	16	1	16	1	16	1	16	1	16
9.30	8.20	12.20	10.80	16.70	14.90	14.50	12.90	7.80	6.90

TL3046		TL3040		TL3038		TL4035		TL5038	
HT	WD	HT	WD	HT	WD	HT	WD	HT	WD
3"	4 5/8" (3 3/8") 2 3/4" (2")	3"	4" (3")	3"	2 3/8" (1 5/8")	4"	3 1/2" (2 3/8")	5"	3 3/8" (2 3/4")
Rectangular									
1	16	1	16	1	16	1	16	1	16
14.50	12.90	12.50	11.10	7.70	6.80	15.10	13.40	15.70	14.00

TL2540		TL3057		TL3050		TL3547		TL5547	
HT	WD	HT	WD	HT	WD	HT	WD	HT	WD
2 1/2"	4" (2 3/4")	3"	5 3/4" (4 1/4")	3"	5" (3 3/4")	3 1/2"	4 3/4" (3")	5.5"	4 3/4" (3")
1	16	1	16	1	16	1	16	1	16
10.80	9.60	21.10	18.80	18.50	16.50	20.80	18.60	26.10	23.30

LB4022
HT 4" WD 2 1/4"(1 1/4")



1 16
11.10 9.80

LB5022
HT 5" WD 2 1/4"(1 1/4")



1 16
13.50 12.00

LB6022
HT 6" WD 2 1/4"(1 1/4")



1 16
14.60 13.00

LB7030R
HT 7" WD 3"(1 3/8")



1 16
14.80 13.20

LB7030L
HT 7" WD 3"(1 3/8")



1 16
14.80 13.20

LF4020
HT 4" WD 2"(1")



1 16
10.90 9.70

LF5020
HT 5" WD 2"(1")



1 16
11.80 10.40

LF5025
HT 5" WD 2 1/2"(1 1/2")



1 16
13.50 12.00

LF6022
HT 6" WD 2 1/2"(1 1/2")



1 16
14.60 13.00

CN6017
HT 6" WD 1 3/4"(3/8")



1 16
6.00 5.30

CN4017
HT 4" WD 1 3/4"(3/8")



1 16
3.60 3.10

CN4025
HT 4" WD 2 1/2"(1 1/2")



1 16
4.90 4.20

CN5017
HT 5" WD 1 3/4"(3/8")



1 16
4.80 4.20

CN5022
HT 5" WD 2 1/2"(2 1/2")



1 16
5.90 5.10

CN6022
HT 6" WD 2 1/4"(1 1/2")



1 16
7.80 6.90

PC2030
HT 2" WD 3"(2 1/4")



1 16
9.80 8.70

PC3030
HT 3" WD 3"(2 1/4")



1 16
10.70 9.40

PC4023
HT 4" WD 2.265"(1 3/8")



1 16
10.60 9.40

PC4030
HT 4" WD 3"(2 1/4")



1 16
11.50 10.20

PC5030
HT 5" WD 3"(2 1/4")



1 16
12.60 11.20

BN2060
HT 2" WD 6"(4 1/4")



1 16
20.80 18.60

BN2550
HT 2 1/2" WD 5"(3 3/4")



1 16
14.20 12.70

BN3051
HT 3" WD 5"(3 3/4")



1 16
19.70 17.60

BN3035
HT 3" WD 3 1/2"(1 3/4")

























1 16
12.60 11.20

BN3050
HT 3" WD 5"(3 3/4")



1 16
16.20 14.40

<p>BF3045</p> <p>HT 3" WD 4½"(2¼")</p>  <p>1 16 16.70 14.90</p>	<p>BF3075</p> <p>HT 3" WD 4¾"(3¾")</p>  <p>1 16 20.90 18.70</p>	<p>BF3240</p> <p>HT 3¾" WD 4"(2¾")</p>  <p>1 16 16.40 14.60</p>	<p>BF3542</p> <p>HT 3½" WD 4¼"(3")</p>  <p>1 16 19.00 16.90</p>	<p>BF4555</p> <p>HT 4½" WD 5½"(4")</p>  <p>1 16 28.40 25.40</p>
<p>BF3050</p> <p>HT 3" WD 5"(3½")</p>  <p>1 16 21.70 18.90</p>	<p>BF3065</p> <p>HT 3" WD 6½"(7¼")</p>  <p>1 16 36.70 32.20</p>	<p>BF4030</p> <p>HT 4" WD 3"(1¾")</p>  <p>1 16 17.30 15.40</p>	<p>BF4245</p> <p>HT 4¼" WD 4½"(3¼")</p>  <p>1 16 25.10 22.50</p>	
<p>BF4537</p> <p>HT 4½" WD 3¾"(1½")</p>  <p>1 16 17.90 16.00</p>	<p>BF4540</p> <p>HT 4½" WD 4"(1¼")</p>  <p>1 16 16.70 14.90</p>	<p>BF5050</p> <p>HT 5" WD 5"(2½")</p>  <p>1 16 22.20 19.90</p>	<p>BF5040</p> <p>HT 5" WD 4"(2½")</p>  <p>1 16 20.80 18.50</p>	<p>BF5740</p> <p>HT 5.687" WD 4"(1½")</p>  <p>1 16 20.10 17.90</p>
<p>BF6040</p> <p>HT 6" WD 4"(1½")</p>  <p>1 16 23.36 20.80</p>	<p>BF6042</p> <p>HT 6" WD 4¼"(2¼")</p>  <p>1 16 23.00 20.50</p>	<p>BF6242</p> <p>HT 6¼" WD 4¼"(2")</p>  <p>1 16 39.30 35.20</p>	<p>BF7060</p> <p>HT 7" WD 6"(2")</p>  <p>1 16 44.00 39.40</p>	
<p>BF6035</p> <p>HT 6" WD 3½"(1½")</p>  <p>1 16 19.50 17.40</p>	<p>BF6032</p> <p>HT 6" WD 3¾"(1")</p>  <p>1 16 16.70 14.90</p>	<p>BF7037</p> <p>HT 7" WD 3¾"(2")</p>  <p>1 16 21.70 19.40</p>	<p>BF8035</p> <p>HT 8" WD 3½"(1½")</p>  <p>1 16 20.30 18.10</p>	<p>BF9535</p> <p>HT 9½" WD 3½"(1½")</p>  <p>1 16 23.90 20.90</p>

QA8537
HT WD
8½" 3¾"(1")



1 16
30.60 26.80

QA9055
HT WD
9" 5½"(1½")



1 16
33.90 29.80

QA9547
HT WD
9½" 4¾"(1¼")



1 16
38.50 33.80

QA9537
HT WD
9½" 3¾"(1¼")



1 16
30.40 26.60

QA1037
HT WD
10¼" 3¾"(1")



1 16
27.20 23.80

QA5035
HT WD
5" 3½"(1¾")



1 16
22.90 20.00

QA5740
HT WD
5¾" 4"(2¾")



1 16
32.50 28.50

QA6557
HT WD
6½" 5¾"(2¾")



1 16
35.50 31.10

QA9065WL
HT WD
9" 6½"(2¼")



1 16
45.40 39.80
WALNUT
FINISH

QA1065
HT WD
10½" 6½"(2¾")



1 16
45.40 39.80

PFB4535
HT WD
4½" 3½"(1¼")



1 16
19.90 17.40

PFB5535
HT WD
5½" 3½"(2¼")



1 16
23.80 20.80

PFB6540
HT WD
6½" 4"(1½")



1 16
26.60 23.30

FR1735BN
HT WD
1.26" 1.46"(1.14")
BRUSHED NICKEL



1 16
17.20 15.40

FR1735BB
HT WD
1.26" 1.46"(1.14")
BRUSHED BRASS



1 16
17.20 15.40

LPB2527
HT WD
2½" 2¾"(1¾")



1 16
10.50 9.10

LPB4527
HT WD
4½" 2¾"(1¾")



1 16
12.30 10.70

LPB6527
HT WD
6½" 2¾"(1¾")



1 16
16.70 14.50

FS1735BN
HT WD
1.26" 1.46"(1.14")
BRUSHED NICKEL



1 16
17.20 15.40

FS1735BB
HT WD
1.26" 1.46"(1.14")
BRUSHED BRASS



1 16
17.20 15.40

MC4535NK
HT WD
4½" 3½"(1¾")
NICKEL



1 16
15.30 13.40

MC4535BN
HT WD
4½" 3½"(1¾")
BRUSHED NICKEL



1 16
15.30 13.40

MC5030BN
HT WD
5" 3"(1")
BRUSHED NICKEL



1 16
33.40 29.20

MC5252NK
HT WD
5¼" 5¼"(1")
NICKEL



1 16
33.80 29.60

MS2410NK
HT WD
2.4" 1"(1")
NICKEL



1 16
8.20 7.10

MS4010NK
HT WD
4" 1"(1")
NICKEL



1 16
9.30 8.00

MS4810NK
HT WD
4.8" 1"(1")
NICKEL



1 16
8.30 7.20

MS6010NK
HT WD
6" 1"(1")
NICKEL



1 16
9.40 8.20

MS7013NK
HT WD
7" 1.35"(1.35")
NICKEL



1 16
30.60 26.80

MS4015BN
HT WD
4" 1½"(1½")
BRUSHED NICKEL



1 16
11.20 9.70

MS5015BN
HT WD
5" 1½"(1½")
BRUSHED NICKEL



1 16
12.80 11.20

MS6015BN
HT WD
6" 1½"(1½")
BRUSHED NICKEL



1 16
15.00 13.10

MS7015BN
HT WD
7" 1½"(1½")
BRUSHED NICKEL



1 16
17.40 15.20

MS8015BN
HT WD
8" 1½"(1½")
BRUSHED NICKEL



1 16
18.60 16.20

MR3020BN
HT WD
3.2" 2"DIAM
BRUSHED NICKEL



1 16
11.40 9.90

MR4020BN
HT WD
4" 2"DIAM
BRUSHED NICKEL



1 16
13.20 11.50

MR4727BN
HT WD
4.7" 2¾"(2")
BRUSHED NICKEL



1 16
22.60 19.80

MR5018BN
HT WD
5" 1¾"
BRUSHED NICKEL



1 16
27.40 24.00

MR6020BN
HT WD
6" 2"DIAM
BRUSHED NICKEL



1 16
15.80 13.70

MR4012NK
HT WD
4" 1¼"(2¼")
NICKEL



1 16
6.30 5.40

MR4812NK
HT WD
4.8" 1¼"(2¼")
NICKEL



1 16
6.80 5.90

MR4818NK
HT WD
4.8" 1.825"(2¼")
NICKEL



1 16
11.10 9.60

MR5317NK
HT WD
5¾" 1¾"(1¾")
NICKEL



1 16
29.30 25.70

MC3627NK
HT WD
3¾" 2¾"(2")
NICKEL



1 16
14.50 12.60

MC3627BK
HT WD
3¾" 2¾"(2")
BRUSHED NICKEL



1 16
14.50 12.60

MC4033NK
HT WD
4" 3¾"(2¾")
NICKEL



1 16
18.10 15.80

MC4033BN
HT WD
4" 3¾"(2¾")
BRUSHED NICKEL



1 16
18.10 15.80

MC5022BN
HT WD
5" 2¼"(1¼")
BRUSHED NICKEL



1 16
26.70 23.40

METAL GLIDES

SINGLE & THREE PRONG GLIDES are precision stamped from a tough, high quality steel or case hardened steel, with sharp shanks tightly embedded in base. All glides are a polished nickel.

SILENT DOMES are manufactured with a thick shock and sound absorbing cushion making them ideal for eliminating vibrations. The hardened steel is finished with a polished nickel.



Single Prong
Nickel Plated



3 Prong
Nickel Plated



Silent Dome
Nickel Plated



Silent Dome
1/4 x 20 Bolt

TYPE	STYLE	NAIL	DIA	PIECE	50	100	1000
Nail	Flat / Nickle	3/4"	3/4"	.54	.32	.22	.12
3 Prong Nail	Flat / Nickle	1/4"	3/4"	.52	.30	.20	.12
Nail	Silent Dome	3/4"	7/8"	.80	.58	.46	.38
Bolt: 1/4"x20	Silent Dome	3/4"	7/8"	.90	.68	.56	.44

NYLON GLIDES



5/8" DIA
Domed - Beige



5/8" DIA
Flat - Beige



3/4" DIA
Flat - Beige



3/4" DIA
Flat - White



Silent Dome
White



1/4" x 20 Bolt
Flat - White



With Installed
"T-Nut"
5/16" x 18 Bolt
Flat - White

NYLON GLIDES - To prevent rust and stains on carpet or tile, choose a plastic glide. These are perfectly formed of tough high density polyethylene and completely uniform in shape. Sharp steel nails drive easily into the hardest wood. Domed glides are perfect for angled legs.

TYPE	STYLE	LENTH	DIA	PIECE	50	100	1000
Nail	Domed/beige	3/4"	5/8"	.60	.30	.20	.10
Nail	Flat/beige	3/4"	5/8"	.62	.32	.20	.12
Nail	Flat/beige	3/4"	3/4"	.62	.32	.20	.12
Nail	Flat/white	3/4"	3/4"	.62	.32	.20	.12
Nail	Silent Dome	3/4"	7/8"	.86	.64	.50	.42
Bolt: 1/4-20	White	1"	5/8"	1.22	.98	.78	.68
Bolt: 5/16"x18	White w/T-nut	1 1/2"	1"	1.30	1.06	.86	.74

SOFT-GLIDE FELT GLIDE

Soft & Quiet - Made with Wool

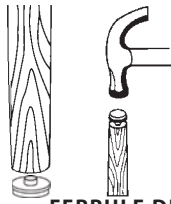

FERRULE DIA
1 1/16"

FELT FLOOR PROTECTORS

For Wooden
Furniture Legs

Ferrule easily nails into wooden legs.

Nylon
Construction

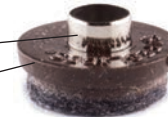

Wool Felt Base

7/8" Diameter

Felt is 3/16" Thick

Soft-Glides install easily with the tap of a hammer into the endgrain of wooden legs. They will not come off and last longer than self-adhesive felt. They will not rust like metal glides and are stronger than nail-in types. Made with wool to protect wood, vinyl, terrazzo marble and tile floors.

FERRULE HT	DIA	PIECE	50	100	1000
3/16"	7/8"	1.20	.84	.64	.46

T-NUTS, BOLTS & SCREWS

TYPE	THREAD	BARREL	PRONG	EACH	50	100	250
Type T-1	1/4" x 20	5/16"	3	.64	.36	.22	.16
Type T-2	1/4" x 20	7/16"	3	.68	.40	.26	.20
Type T-3	1/4" x 20	9/16"	3	.68	.42	.28	.22
Type T-4	5/16" x 18	5/8"	3	.70	.42	.30	.22
Type T-5	7/16" x 16	3/8"	3	.78	.50	.36	.30
Stainless Steel	1/4" x 20	5/16"	3	2.00	1.60	1.50	



DOWEL SCREW: 5/16"

HANGER BOLT: 5/16" x 18

Length: 3"

1	12	24
.90	.62	.42
1	12	24
.90	.62	.42

LEG PLATES

STYLE & PITCH	NO	EACH	DOZ	2 DZ
Square / Flat	7	3.00	2.70	2.34
Square / Angle	7A	3.00	2.70	2.34
Triangle / Flat	20	3.40	3.10	2.74
Triangle / Angle	1	3.40	3.10	2.74

Pitched & Flat

Threaded to fit: 5/16" x 18

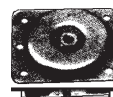

#7 Square/Flat



#7-A Square/Angle



#20 Triangle/Flat



#1 Triangle/Angle



CYPRESS™ SPRAY LACQUERS

PROFESSIONAL GRADE
FINISHES & TONERS

WOOD STAINS 100 SERIES

A combination of pigment, light resistant stains, seal and lacquer. Will cover any scratched or marred surface.

NATURALS 200 SERIES

A combination of stain, sealer and lacquer. Used primarily on a new wood or where the grain should be visible.

ALSO AVAILABLE:

300 Clear Flat 305 Flat Oil Finish
301 Satin Clear Flat 306 Sanding Sealer
302 Ultra Flat Clear 307 Lacquer Leveler
303 Gloss Clear 308 Semi-Gloss Clear

307 Lacquer Leveler — will blend in and level out overspray and orange peel areas.

NOTE: A clear protective finish is recommended over most stained surfaces for added durability, especially if surface will be subject to wear or to frequent cleaning.

GUARANTEE

We guarantee all Cypress Point products to cover as much surface, apply as easily, last as long, and look as good as any similar products, regardless of name or price. We guarantee Cypress Point products will give satisfactory results, whether applied by professional or amateur, if used according to instructions.

Made in U.S.A. for Cypress Point, LLC
8407 S. 77th Avenue, Bridgeview, IL 60455



NOTE: All colors shown have been reproduced as accurately as possible. Final results will vary, according to type and color of wood to be stained. We suggest testing stains for color in an inconspicuous place before making the entire application.

*** = discontinued; stock may be available

- 101 TRUE MAHOGANY
- 102 ROCK MAPLE***
- 103 TRUE WALNUT***
- 104 CORDOVAN MAHOGANY***
- 105 FRENCH WALNUT***
- 106 SHADOW WALNUT***
- 108 DEEP WALNUT

- 109 SANDY FRUITWOOD***
- 110 BROWN MAHOGANY
- 112 NUTMEG
- 113 LIGHT FRUITWOOD
- 114 AMERICAN WALNUT***
- 115 RAW UMBER
- 116 BURNT UMBER

- 117 TRUE MAPLE
- 118 PROVINCIAL MAPLE***
- 119 MEDIUM WALNUT
- 120 DARK OAK***
- 121 RED MAHOGANY/CHERRY
- 122 EXTRA DARK WALNUT
- 201 NATURAL WALNUT***

- 202 NATURAL MAHOGANY***
- 203 NATURAL MAPLE***
- 205 NATURAL OAK
- 206 VAN DYKE BROWN***
- 207 GOLDEN OAK***
- 402 EBONY BLACK
- 403 NATURAL WHITE***
- 404 ANTIQUE WHITE
- 409 FLAT WHITE***

TOP COAT LACQUER, LEVELER & SEALER

- 300 CLEAR FLAT
- 301 SATIN CLEAR FLAT
- 302 ULTRA FLAT CLEAR***
- 303 GLOSS CLEAR

- 305 FLAT OIL FINISH
- 306 SANDING SEALER
- 307 LACQUER LEVELER

TOP COAT URETHANES & SHELLAC

- 304 SHELLAC***

- 601 SATIN POLYURETHANE***



	CAN	MIX DOZ	DOZEN	3 DOZ
Aerosol: 13oz	20.40	18.30	17.50	15.80

TOUCH-UP MARKERS

Premier

VALVE-ACTION STAIN MARKERS

PREMIER'S Touch-Up Marker is a valve type marker which seals, stains and finishes in one easy step. Touch-Up Markers are available in many of the most popular shades and can be applied over wood fills, "rub throughs" or worn edges to create an invisible repair. Touch-Up Markers may be used with all types of finishes without worry.

- 202 NATURAL
- 210 RED OAK
- 211 COLONIAL MAPLE
- 212 FRUITWOOD
- 215 UNIVERSAL CHERRY
- 216 LIGHT WALNUT
- 219 UNIVERSAL WALNUT
- 220 MEDIUM WALNUT
- 224 BROWN CHERRY
- 227 TRADITIONAL MAHOGANY
- 229 BROWN RED MAHOGANY
- 230 DARK OAK
- 233 DARK WALNUT
- 234 DARK PECAN
- 237 BLACK



	EACH	½ DOZEN	MIXED DOZ	DOZEN
Per Touch-up Marker	8.30	7.30	6.90	6.30

TOUCH-UP STICKS

Premier

WAX-BASED COLORED STICKS

A rub-on wax pencil that fixes and eliminates scars, scratches, gouges, and abrasions on furniture, picture frames, leather, china, plastics and paneling. Accepts any type of top coat.

- 102 NATURAL
- 103 NATURAL LIGHT OAK
- 109 LIGHT OAK
- 113 HERITAGE OAK
- 114 MAPLE
- 120 MEDIUM WALNUT
- 127 TRADITIONAL MAHOGANY
- 129 BROWN RED MAHOGANY
- 132 MEDIUM DARK WALNUT
- 133 DARK WALNUT
- 182 OFF WHITE
- 189 PICKLE FROST



	EACH	½ DOZEN	MIXED DOZ	DOZEN
Per Touch-Up Stick	4.40	3.90	3.50	3.10

JIFFY ESTEAM

Features

- Made in USA
- Removes wrinkles from clothing, drapery, tablecloths, bedspreads and upholstery
- Guaranteed not to scorch or burn any fabric
- 600 Watt heating element with automatic safety thermostat
- Three times more power than similar steamers
- Steam in three minutes with powerful continuous flow of steam
- Doubled insulated outer housing for cool-to-touch operation
- No pumps or water lines to become plugged
- Uses plain tap water (no salt)
- Largest reservoir on the market (10.5oz)
- Water level window on both sides
- Wide mouth easy to fill
- Same internal wiring & thermostat controls as our industrial models
- 9ft long power cord
- Fits easily into attache case
- Weight: 1lb 9oz

*The world's most powerful
hand-held steamer!*



ESTEAM PORTABLE

EACH
183.00

JIFFY CLEANER

- Made in U.S.A. since 1940
- Can be used in all Jiffy Steamer models
- Unique de-scaler removes hard water deposits from all internal parts.
- Easy to use



First and still the finest!

10oz Bottle 16.60

JIFFY J-2 and J2000 STEAMERS

J-2 versus the J-2000. The traditional J-2 is still made with a rugged cast aluminum body to take the punishment of commercial workrooms. The J-2000 offers an up-to-date design, using a high impact polymer outer shell with an integrated water reservoir. The newer reservoir's lower profile allows it to fill easier from faucets, with only a small sacrifice of ½ hour less capacity of steam; otherwise, the components are virtually identical.

*The original first and still the finest!
Made in U.S.A. since 1940!*

Features

- Quick 2-minute heat-up time
- 1300 watt heating element die cast in solid brass
- 50/60 Hertz electrical system
- Fusible link with automatic shut-off for safety
- New Noryl steam head, lighter weight and cool-to-the-touch
- 360 Degree swivel caster set for mobility
- "No Spill" check valve cap
- J-2000 has a high-impact polymer outer housing
- J-2000 has a low profile, easy-to-handle water reservoir
- J-2000 has over 1.5 hours of steam per filling
- J-2 has die cast aluminum outer housing for durability
- J-2 has an impact resistant one gallon water reservoir
- J-2 has over 2 hours of steam per filling



New Hook

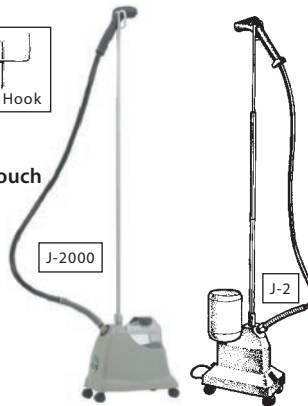

STEAMER

J-2 EACH 438.00
J-2000 EACH 438.00

J-2000 PARTS

Plastic Jar 20.90
Plastic Jar w/value (New) 35.90
J-2000 Switch: Toggle 27.20
J-2000 Switch: Rocker 42.00
J-2000 Heating Element Kit 238.70

All 3 MODELS: hoses, heads and stand

Plastic Head Only 65.00
Metal/Wooden Head Only 114.50
Wooden Handle only (for Metal Heads) 23.00
Hose(5½') w/ Plastic Head 152.70
Hose(7½') w/ Plastic Head 152.70
Hose(5½') w/ Metal/Wood Head 213.50
Hose(7½') w/ Metal/Wood Head 213.50
Rod Stand 79.10

JIFFY J-4000 STEAMER

Model J-4000 for upholstery. Ideal for furniture and upholstery shops. Moisture and heat allows fabrics to be stretched when installed. Will dry in minutes without a wrinkle or pucker.

Model J-4000D for Drapery. Features a standard 7½' long hose allowing for extra long reach.

Model J-4000A for Auto Trim. Removes wrinkles, stretches fabrics, shrinks fabrics and tightens seams. Comes with dual iron head for hard to reach areas. Comes with extra pipe head.

Features

- Durable die cast aluminum outer housing unit
- Color-coded high temperature wiring
- Convenient PREHEAT and STEAM settings
- 1500 watt incoloy heating element
- 50/60 Hertz electrical system
- Fusible link with automatic shut-off for safety
- Over 1.5 hours of steam per filling
- Corrosion-proof internal 304 stainless steel boiler tank
- No water lines to be clogged by water deposits
- Built-in easy-to-read water level sight gauge
- Sediment build-up indicator



Auto Pipe Head



*The original first and still the finest!
Made in U.S.A. since 1940!*

The J-400 Pro-Line Series is Jiffy's Steamer's most powerful model designed for commercial purposes. Known as a durable "workhorse" in the industrial fabric and garment trades, the Model J-4000 is an essential tool in a multitude of applications ranging from removing wrinkles, to retouching drapery and installing carpet. Coupled with the several available hose attachments, the J-4000 Pro-Line Series Jiffy Steamer is a welcome presence in any industry.

J-4000 PARTS

J-3 Switch (older model) 117.40
J-4000 Heating Element 100.00
L-220 Thermostat (steam) 32.20
L-170 Thermostat (preheat) 32.20

STEAMER

J-4000 EACH 618.00
J-4000A Automotive Head 678.00
J-4000D Drapery - extra long hose 630.00

CURVED NEEDLES-ROUND POINT

EXTRA THIN
FOR SILK & DELICATE FABRICS

SIZE	GA.	EACH	DOZEN
3"	21	5.20	3.30
4"	19	5.90	3.90



CURVED NEEDLES-ROUND POINT

SIZE	GA.	EACH	DOZEN
2"	21	3.90	2.10
3"	19	4.80	2.90
4"	18	5.00	3.10
5"	16	5.40	3.40
6"	15	5.40	3.40
8"	15	7.70	5.40

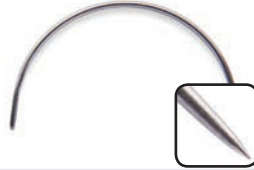

CURVED NEEDLES-LEATHER POINT

SIZE	GA.	EACH	DOZEN
2"	19	7.00	4.80
3"	18	7.30	5.10
4"	17	8.60	6.20
5"	16	10.00	7.40
6"	15	10.90	8.20
8"	15	13.50	10.50



STRAIGHT-SINGLE ROUND POINT

SIZE	GA.	EACH	DOZEN
8"	14	7.00	4.60
10"	13	9.70	7.10
12"	13	10.40	7.60
14"	13	12.00	9.00
16"	12	12.70	9.70
18"	12	14.10	10.90



STRAIGHT-SINGLE LEATHER POINT

SIZE	GA.	EACH	DOZEN
8"	13	10.90	8.10
10"	12	15.80	12.40
12"	12	16.30	12.80
14"	12	16.90	13.40
16"	11	17.80	14.10
18"	11	23.40	19.00



STRAIGHT-DOUBLE ROUND POINT

SIZE	GA.	EACH	DOZEN
8"	14	8.10	5.60
10"	13	10.60	7.80
12"	13	11.20	8.30
14"	13	12.90	9.80
16"	12	13.90	10.70
18"	12	15.00	11.70



STRAIGHT-DOUBLE LEATHER POINT

SIZE	GA.	EACH	DOZEN
8"	13	12.30	9.30
10"	12	17.00	13.40
12"	12	18.60	14.90
14"	12	20.10	16.10
16"	11	21.50	17.40
18"	11	24.90	20.40



UPHOLSTERY PINS

3 1/2" LENGTH



		BOX
DOZEN	(12)	10.32
1/4 GROSS	(36)	23.76
GROSS	(144)	74.88

"T" PINS

1/2 Lb BOXES



SIZE	LENGTH	BOX	6 BOXES
No. 20	1 1/4"	30.40	25.40
No. 24	1 1/2"	30.40	25.40
No. 32	2"	30.40	25.40

PLASTIC HEADED PINS: BLUE



LENGTH: 2 7/8"

	EACH	6 BOXES
100 PINS / BOX	58.30	54.20

DRESS MAKER PINS

ONE POUND BOXES



SIZE	LENGTH	BOX	6 BOXES
No. 20	1 1/4"	22.60	20.40
No. 28	1 3/4"	22.60	20.40
No. 32	2"	22.60	20.40

OSBORNE K-3 NEEDLE KIT



SIZES: 3" 4" 5" 6"
Gauges: 18 17 16 15
Includes: One of Each

	EACH	12
CARD	11.20	9.20

TWIST PINS

Clear Head, Stainless Steel Pin



	EACH
100 PACK	37.70
1000 PACK	327.60

REGULATORS

	EACH
6" & 8" Metal	17.80
10" Metal	17.90
12" Metal	20.70
10" Plastic Handle	20.40
9" Ice Pick	5.00



HAMMERS

No. 33 Bronze Magnetic (solid head) 7 Oz.	67.50
No. 34 Hammer Handle	10.10
No. 39 Bronze Magnetic (solid head) 9 oz.	77.40
No. 222 Magnetic Split Head 7.5 Oz.	70.80
No. 36 Nylon Tip Hammer 7.0 oz.	82.30
No. 36-T Nylon Tips	9.00
No. 396 Rubber Mallet	35.70
No. 89.5 Hickory Mallet 3½" 12oz.	43.40
No. 196 Rawhide Mallet No.4	75.70

C.S. OSBORNE



PLIERS



C.S. OSBORNE



No. 445 Spring Clip Pliers - 3 Prong	139.90
No. 91 Diagonal Cutting Nippers	22.80
No. 94 End Cutting Nippers	33.70
No. 522 BW Clip Pliers	103.20
No. 7658 Offset Hog Ring Plier (with closing spring)	68.70
No. 7657 Straight Hog Ring Plier (with closing spring)	70.60
No. 98 Duck Bill Pliers	83.70
No. 1440 Hog Ring Pliers (A) (not spring aided)	59.30
No. 1440 Hog Ring Pliers (B & C) (not spring aided)	64.10
No. 787A Side Cutter	113.70
No. 600 Plier Staple Remover	55.80
No. 602 Plier Staple Remover w/Post	158.10



TACK & STAPLE LIFTERS

C.S. OSBORNE

No. 124 Berry Remover	31.80
No. 124-12 Berry's Long Handle	60.10
No. 120.5 Staple Remover	41.10
No. 120 Staple Remover	41.10
No. 402 Ripping Chisel	31.40
No. 402.5 Combo Tack Lifter/Ripper	31.80
No. 121 Tack & Staple Remover	43.30
No. 202 Tack Claw	39.90
No. 763 Grove Staple Remover	28.40
No. 710 Sharp Point Grove Staple Remover	47.00
No. 1066 Staple Remover	47.10

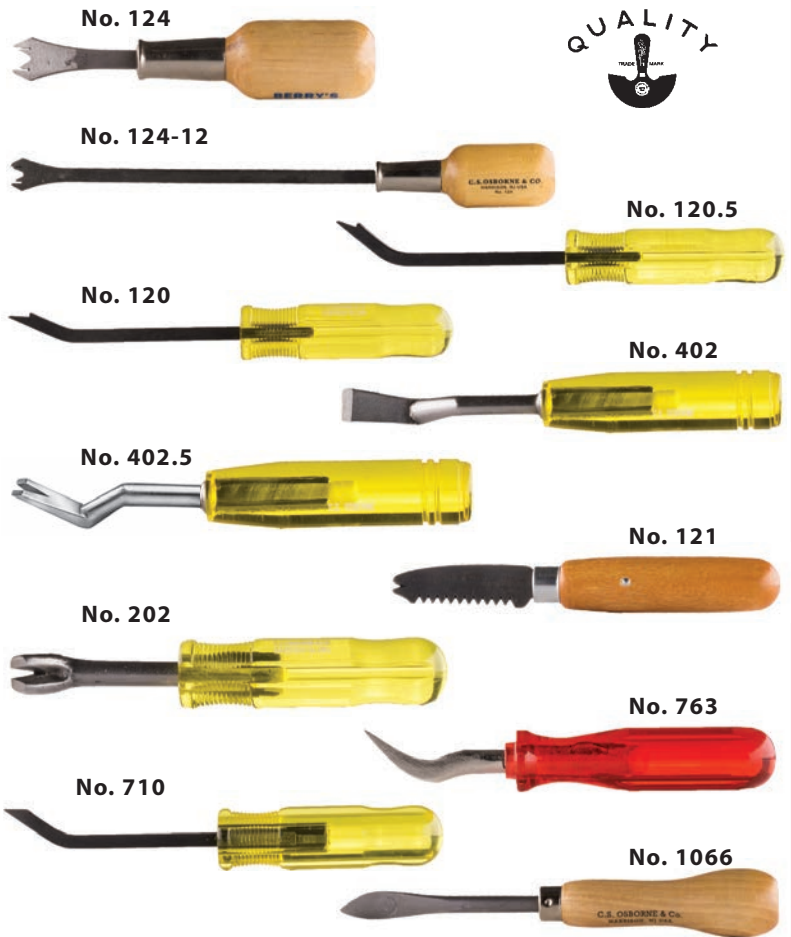

STRETCHERS

No. 255 Webbing Stretcher	31.80
No. 253 Webbing Stretcher	62.90
No. 258 Metal Webbing Stretcher	72.20
No. 251 Leather Stretcher 1½"	88.00
No. 250 Leather Stretcher 3"	85.10
No. 261 Elastic Webbing Stretcher	59.90
No. 263 Rubber Webbing Stretcher	120.90
No. 268 Lever Spring Stretcher	68.60

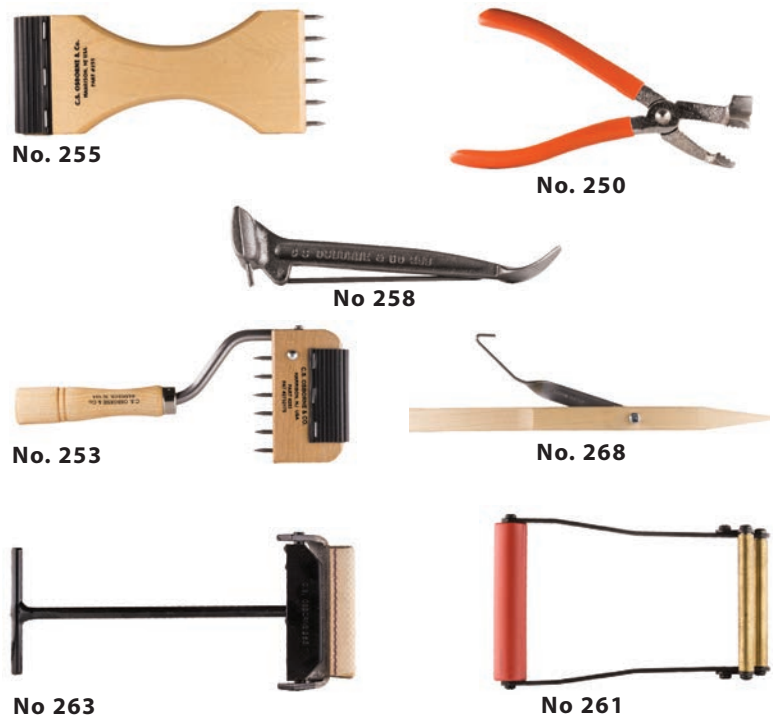

KNIVES



No. 76.5 Square Point Knife 18.50



No. 79.5 Sharp Point 17.30

RAZORS

SINGLE EDGE

PER 100

100
17.60



500
15.20

1000
13.40

SKIVE

No. 925 Skive
Extra Razors (20)

EACH
19.80
22.50



#18 AWL



#18 AWL 24.60

SEWING AWL



No. 413 Sewing Awl 49.50
Replacement Needles: 5" Straight 11.30
Replacement Needles: 6" Curved 11.30
Bobbins with Brown Thread 14.60

SEAM RIPPER

Zip Rip with safety ball.
Makes seam opening easy.



SEAM RIPPER 6.50

TWEEZERS



Length: 6"

METAL TWEEZERS EACH 11.90

STEEL PINCH DOGS



Steel Pinch Dogs EACH
No. 89 1 1/2" 12.20
No. 89 2" 12.60

TRIMMERS' STUFFING IRON



No. 118 EACH 71.30

- Made especially for the trimmer.
- Hand forged of fine quality polished steel
- Length: 16 inches
- Width at point 1/2"
- Top quality

SEWING MACHINE NEEDLES



18 GAUGE



24 GAUGE

ENLARGED TO SHOW DIFFERENCES

SIZE	GAUGES	1pk.	10pk.
134 x 35	16 19 22 23	17.00	96.00
16 x 63	19	17.00	96.00
135 x 17	18 19 20 21 22 23 24	17.00	96.00
135 x 16	18 (LEATHER POINT) 24	21.40	148.00
190R	18 19 20 21 22 23 24	19.00	134.00
16 x 87	21	17.00	96.00

MACHINE MODELS
Adler 167GK373, 267GGK373, Pfaff 190H, H3
Consew 18 & 118 and Rex 26-188
Consew 206RB, Consew 226, 225, Juki LU 562
Singer 111W, Singer 211U, Nakajima
Consew 206RB, Consew 226, 225, Juki LU 562
Singer 111W, Singer 211U, Nakajima
Pfaff 545-H4 & 1245
Singer 31-15



10 needles per pack



ACTUAL SIZES

FILLER BAZOOKA



- Can be used with down, Kapok, shredded foam, styrofoam pellets and other loose materials.
- Bright, light weight aluminum - 2" diameter, 30" length
- Operates with 80 lbs. pressure

#302 BAZOOKA (includes Blo-Gun)

103.40

REVOLVING PUNCHES



ECONOMY GRADE

No. 223 Economy: Heat Treated Tubes

35.20



INDUSTRIAL GRADE

No. 155 Industrial Punch: High Carbon Steel

176.40

No. 155 Replacement Cutters: (Per Each, All Sizes)

15.10

No. 155 Replacement Anvil

10.90

PIPING TINS



	SET
No. 412 2"	61.00
No. 412 3"	90.60
No. 412 4"	100.60

SEAM STRETCHER



No. 267 Seam Stretcher (Equalizer)

155.10

TUFTING NEEDLES

Actual Size



STANDARD		Each	
No. 417 TUFTING NEEDLES		76.80	
	100		500
No. 418 TUFTING CLASPS	10.10		36.10

PRONG TUFTER



No. 419 Prong Tufter

Each
33.90

RULERS & MEASURING TAPES

TYPE	STYLE	LENGTH	WIDTH	EACH	SIDES MARKED
Wooden	160	60"	1 ¹¹ / ₁₆ "	107.20	One
Wooden	160	72"	1 ¹¹ / ₁₆ "	65.20	One
Aluminum	802	36"	1 ¹ / ₂ "	32.40	One
Aluminum	802	60"	1 ¹ / ₂ "	33.10	One
Aluminum	161	60"	1 ¹ / ₂ "	25.20	Both
Gripper Tape		25Ft	1"	17.90	One
Stick & Tape		12Ft	1"	14.70	One



No. 160: One Edge marked in "Inches" on one side.

No. 802: One Edge marked in "Inches", one in "Metric"

No. 161: One Side marked in "Inches", one side in "Metric"

ALLSTAR ROTARY FABRIC CUTTER

IMPROVE YOUR EFFICIENCY!

ALLSTAR-100 FABRIC CUTTER 353.30

ACCESSORIES	EACH
SHARPENING STONE	10.10
SHARPENING SPRING	1.10
SHOE	15.60
SHOE CREW	.70
CUTTING GLIDE	41.80
HEXANGONAL ROTARY BLADE	19.30
UPPER BLADE with CARBIDE TIP	37.10
CUTTING BLADE SCREW	1.10
KNIFE LOCK SCREW	6.40
GEAR ASSEMBLY	32.60
MOTOR ASSEMBLY DISC	9.40
MOTOR SHAFT COUPLING	5.30
MOTOR ASSEMBLY	217.40
MOTOR BRUSH	5.00



- High torque motor
- Squeeze type switch with comfort grip
- Built-in "push-button" sharpener
- Hexagonal blade rotates against counter blade for smooth cutting
- Cut intricate curves without snagging

KAI SHEARS

- AU-6 Stainless Steel with Molybdenum Vanadium for hardness and durability.
- HRC 56 – 58 (hardness Rockwell C scale)
- Pivot: Easily adjustable nut with nylon insert to prevent loosening. (nylon stop nut)
- Handles: Larger, more ergonomic, (easy on the hands), unbreakable black Santoprene® soft thermal plastic. (not ambidexterous)

- Larger handles to allow using all fingers during cutting!
- Soft Santoprene insert to cushion your hands!
- Nylon insert to prevent loosening!



MODEL	CUT	LENGTH	EACH
5220	3 ³ / ₈ "	9"	58.00
5220-L	3 ³ / ₈ "	9"	58.50

KAI SHEARS

- Light weight AND stronger than most all metal shears!
- Professionally honed cutting edge.
- Ergonomically styled and padded grip made of "Elastomer" soft plastic for maximum ease of handling.
- Larger handles to reduce stress.
- Thicker blades for heavy duty cutting.
- Full-length "blade-to-grip design for optimal cutting balance.
- Novel Duplex Interlock Screw for lasting blade tension.
- Available in 3 sizes
- A -8 High Carbon Molybdenum Vanadium Stainless Steel for extra long life & cutting efficiency.
- Approximately 60 HRC - one of the hardest & smoothest shears available.

- Double-locking nuts for strength!
- Steel throughout handles for strength!
- Soft Santoprene insert to cushion your hands!



MODEL	CUT	LENGTH	EACH
7250	3 ³ / ₄ "	10"	167.00
7280	5"	11"	201.50
7300	5 ¹ / ₂ "	12"	223.50

DESCRIPTION EACH
Repair Kit 11.50



WISS UPHOLSTERY SHEARS

STYLE NO.	SIZE	EACH
No 1DS	8"	51.00
No. 28	8"	64.20
No. 29	9"	73.20
No. 20W	10"	104.80
No. 20	10"	83.80
No. 20 Lefty	10"	93.10
No. 22W	12"	125.60
No. 22	12"	103.40
TC-1 Thread Snips		42.00
Economy Thread Snips		8.00



No 1DS

Wiss®



No. 28 & No. 29



No. 20 Lefty



No. 20 & No. 22



TC-1



No. 20W & No. 22W



Economy Thread Clips

UNIVERSAL HAND SHEAR SHARPENERS

TWICE AS SHARP® Scissor Sharpening System

SHARPEN YOUR
OWN SHEARS LIKE A
PROFESSIONAL!

- ½" wide sharpening wheel, 100 grit friable aluminum oxide grain structure prevents burning.
- Able to sharpen 20 to 30 blades per hour; no need to disassemble
- Shears-Lock clamp opens wide for thick blades, self adjusts for blade taper
- Eye shields, wheel covers and finger guards for safety.
- Honing wheel or standard buffing wheel produces shears 2 to 6 times sharper than new.
- Free floating arm system and sealed bearings provide years of maintenance free use.



2 YEAR
WARRANTY!

ELECTRIC SHARPENER

958.00

AIR POWERED BANTAM BINDER RIPPER



Amazingly Lightweight

2 Chisels Included

8-Position Locking Slip Chuck

Variable Speed Trigger

REMOVES
Staples
Couch panels
Bindings
Welt
Tackless strips
Tacks
Zig-Zag clips
and more!

The smallest air hammer made!
1/3 the weight of clumsy auto tools!
A great deal quieter too!

The air-powered Bantam Ripper weighs only 1 1/4 lbs and removes upholstery 50% faster. The air hammer comes with 2 chisels for ripping couch panels, pulling tacks, and removing welts, tackless strips, and zig-zag clips. The Bantam Ripper has a variable-speed trigger and a locking chisel retainer that can hold the chisel in 8 different positions.



BANTAM RIPPER (Comes complete with both chisels)
#11300 Tack Puller Chisel
#11702 Staple Remover Chisel

422.30
61.60
62.50

WOODEN DOWEL



Length: 2"

	100	1000
3/8"	13.60	82.60
7/16"	14.40	90.00
1/2"	17.60	116.60

BUTTONS & PLUGS

WOOD BUTTONS

WOOD PLUGS



	BUTTONS		PLUGS	
	100	1000	100	1000
3/8"	16.60	108.60	15.80	101.00
1/2"	16.60	108.60	15.80	101.00
5/8"	24.20	173.60	20.80	144.60

CUSHION HOOK & RINGS



HOOKS	SIZE	1	24	100	400
	1/2"	1.26	.92	.64	.56
D-RINGS	SIZE	1	24	100	400
	1/2"	.56	.28	.14	.06

ELASTIC: LIGHT WT.

COLORS: WHITE & BLACK
WIDTHS: 1/2", 3/4", 1"
SPOOLS: 100 YARDS
TYPE: FLAT BRAIDED



WIDTH	WHITE	BLACK
1/2"	82.60	93.90
3/4"	101.40	105.10
1"	138.90	142.60

GRIP-PAD® Non Slip Padding

CHURCH PEWS • UNDER CARPETING • MANY MARINE USES

FOR USE:

- Under carpets and rugs
- Cushions and futons
- Armrest covers and more

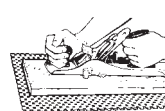
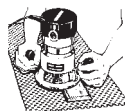

If you don't want it to slip,
use SUPER GRIP!

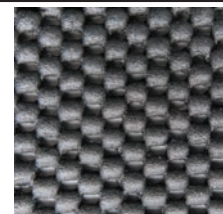

close up

	COLORS	WD	FT/RL	CUTS	10 FT	ROLL	
Grip Pad	Tan	24"	100	6.20	3.30	2.20	per foot
Premiere Grip Pad	Black or White	24"	65	6.50	3.60	2.50	per foot
Premiere Grip Pad	Black or White	36"	65	7.70	4.80	3.70	per foot
Premiere Grip Pad	Black or White	72"	65	15.10	9.30	7.10	per foot

CHALKS & MARKERS



Wash-out Textile Pencil



Tailors Chalk



China Marking Pencil



Chalk



Silver Vinyl Marking Pen

VINYL MARKING PENS: Silver

Use on vinyl, leather, and many more fabrics.

TEXTILE PENCILS: White, Blue, Red & Green

A special formulation designed wash out from most fabrics.

REDIMARK FOAM MARKERS: Blue

A permanent marker with a chisel-tip that allows for easy drawing on foam.

TAILORS CHALK: Black, White, Yellow & Red 32 Pieces/Box

Composition chalk in beveled squares; compressed for non-crumbling.

PRANG HYGEIA HARD SCHOOL CHALK: White

Hard round sticks. 144 sticks: 12 sticks/box, 12 boxes/carton. The most popular fabric marker.

PRANG HYGEIA HARD SCHOOL CHALK: Yellow

Hard round sticks. 144 sticks: 12 sticks/box, 12 boxes/carton. The most popular fabric marker.

WALTHAMS TAPERED CHALK STICKS: White

Soft tapered round sticks. 144 per box.

CHINA MARKING PENCILS: Black, White, Yellow

Write on, wipe off. Use on Vinyl, Leather, and many more fabrics.

	EACH	DOZ
VINYL MARKING PENS: Silver	13.00	11.00
TEXTILE PENCILS: White, Blue, Red & Green	2.50	1.90
REDIMARK FOAM MARKERS: Blue	4.30	3.30
TAILORS CHALK: Black, White, Yellow & Red 32 Pieces/Box	22.00	-
PRANG HYGEIA HARD SCHOOL CHALK: White	21.10	-
PRANG HYGEIA HARD SCHOOL CHALK: Yellow	21.10	-
WALTHAMS TAPERED CHALK STICKS: White	21.10	-
CHINA MARKING PENCILS: Black, White, Yellow	2.30	1.70

CONSEW FOAM CUTTER

- Heavy-duty for fast, production cutting of all densities of foam rubber and flexible plastic forms.
- Versatile-will cut all types of carpeting including shag and foam-backed.
- Quick blade change.
- Slim motor housing fits even the smallest hand.
- 90 Day Warranty

Complete 8" Foam Cutter	1,363.20
Complete 12" Foam Cutter	1,413.60

Description	Each
8" Blade	94.60
8" Blade Guide	177.80
12" Blade	110.10
12" Blade Guide	216.50
Foot Plate	177.80
Motor	975.00



"ACU-CUTTER" FOAM CUTTER

- Heavy duty safety stanchion
- Solid steel construction
- Free standing
- Detachable foot plate with rollers
- Blade length: 9"
- Foot equipped with glide bearings
- Removable foot-plate
- 3,200 Rpm. Variable speed.

*INTRODUCING THE FIRST
HIGH QUALITY,
HIGH PERFORMANCE,
YET MODERATELY PRICED,
FOAM CUTTER*

WARRANTY: Foam Queen Ltd. warrants this product for one year against any defects due to faulty material or workmanship. The unit should be returned complete, transportation prepaid, to the seller for free replacement. Proof of purchase may be required. This warranty does not apply to accessories, such as blades. This warranty gives you specific legal rights and you may have other rights which may vary from state to state.

MODEL	DESCRIPTION	MOTOR	HP	EACH
ACU-CUTTER: #350	Single Action Blade	4.0 amp	1/3	590.00
ACU-CUTTER: #500	Double Action Blades	4.0 amp	1/3	850.00
REPLACEMENT BLADES	Acu-Cutter: 8" Length			78.00
REPLACEMENT BLADES	Foam Queen: 9" Length			118.00



FOAM SCULPTING DISCS

*Power Through Sculpting
With Just a Light Touch!
Attach Discs To Any Power
Drill!*

3½" Curved Disc	45.60
3½" Flat Disc	20.20
5" Flat Disc	29.50
Mandrel	19.80
Full Set	109.35



Sculpting Discs are Pictured with Mandrel, but do not come with discs, purchased separately.



Power drill not included
Take care to come off of the trigger slowly when using battery-powered drills, as sudden stops will cause the mandrel to unscrew.

SILK FILM & EZE CUSHION STUFFER

**SUPER
SOFT
& SILKY
NOISELESS
SILK FILM**

CUSHION STUFFER

- Plugs into 110 electric outlet
- Draws down foam quickly for easy stuffing
- Easy to operate right on your work table

SIX Easy Steps:

- 1) Lay foam on top of "Eze" Cushion Stuffer
- 2) Drape "Eze" film over foam
- 3) Turn on "Eze" Cushion Stuffer
- 4) Slip cover over foam and turn off Stuffer
- 5) Adjust cover as foam expands
- 6) Pull foam and cover off the board



Height: 9"
Width: 14"
Length: 24"



EZE CUSHION STUFFER	EACH	SILK FILM	WIDTH	100 YD RL	20 LB RL	70 LB RL
	670.00	CENTER FOLD SINGLE WOUND	54" 54"	48.90 -	228.70 -	- 790.30

OSBORNE #1212 FOAM DRILLS

- The Osborne cutter is made to cut FOAM, VINYL, FABRIC, POLY, and other soft materials.
- Cutters have special carbonized hardened edges.
- Makes diamond tufting easy.
- Makes button circles fast and easy - up to 30 buttons at a time.
- Use with a drill press or a hand held drill.

DIAMETER	BUTTON CONVERSION	EACH
1/2"	-	116.20
3/4"	-	121.70
7/8"	-	121.70
1"	22	150.20
1-1/4"	30	150.20
1-7/16"	36	150.20
1-1/2"	40	150.20



C.S. OSBORNE



Jig for Cutters 51.10

OSBORNE U-CUTTER

U-Cut is fast, flexible and foolproof. The operator places U-Cut on a table or on the floor along with the slab of material to be cut. The desired cutting thickness is quickly obtained by means of an adjustable screw setting. The operator then merely pushes and pulls U-Cut in a saw-like action and in seconds, the desired cut of material has been made neatly and accurately. U-cut can also be used to make wedges, curves, arcs and other special shapes by making an inexpensive form to support the material to be cut. These are used particularly for orthopedic seating, auto, as well as furniture.

U-Cut will cut from a minimum of 1/4" to a maximum thickness of 9". Material up to 36" in width and unlimited length can be processed.



#410 U-CUTTER 229.60
#410-B EXTRA BLADES 57.10

UPHOLSTERY PRESS

- ✓ *It's Quick!*
- ✓ *It's Easy*
- ✓ *It Boosts Production!*
- ✓ *It Produces a Better Product!*

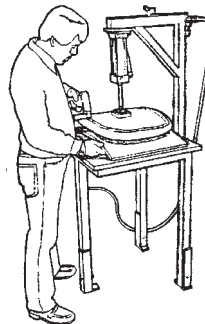

TECHNICAL SPECIFICATIONS

Overall dimensions:	30"DP x 34"WD x 60"HT
Table Size:	24" x 34"
Throat Dimension:	16"
Working Height:	12"
Cylinder Size:	2" DIA bore 6" Stroke
Air Pressure Req:	90 PSI
Height Adjustment:	3"
Tube Specifications:	2" x 2" x 10ga CRS

PRESS 5,194.00

- Made for high or low production use.
- Extra heavy steel tubing construction to last for years.
- Three leg construction, to minimize leg obstruction during operation.
- Adjustable leg height to adjust to uneven floors.
- Designed to accommodate upholstery of all office furniture seats and backs.
- Can do curved or flat seats in any shape. Provides consistency needed to ensure quality.
- Design allows operator to be hands free and maintain consistent pressure. Pressure is adjustable by a pneumatic air regulator that is standard.
- One lever operation for clamping and unclamping. Heavy duty pneumatic cylinder and actuator controls. Non-electric.
- Air regulator attached to control air pressure or air cylinder for various seat and back foam densities.
- Large work area with high pressure laminate top and "t" molded with PVC bumper.
- The Upholstery Press comes pre-assembled ready to hook up to your air assembly. 90 PSI required.
- Typically 1-2 Week Delivery. May take up to 6-8 weeks.

GANGING DEVICE CONNECTOR: FLAT

- Mounts flat horizontal surfaces
- Steel - zinc plated
- Connects modular furniture
- Easily connects to opposing piece
- When not used - pivots under surfaces
- Easily fastens under furniture

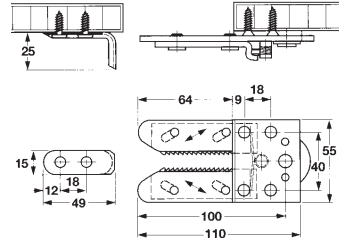

	PAIR	6 PAIR	12 PAIR	24 PAIR
Flat Connector <i>per pair</i>	26.60	24.60	22.60	20.60

PANEL CLIPS

Made of High Strength Aluminum

Great for hanging

- Upholstered boards
- Head boards
- Boothbacks
- Wall panels
 - Bulletin boards
 - Shelves
 - Wall cabinets
 - Wall accessories

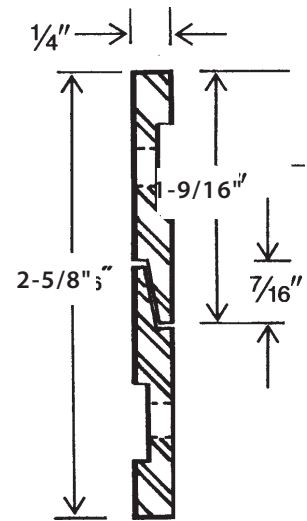
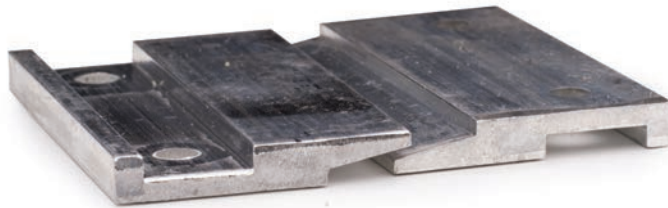

	PAIR	10 PAIR	50 PAIR	100 PAIR
Cleat <i>per pair</i>	8.18	7.38	6.98	6.42

INTERLOCKING HANGERS

**flush
mount™**

Flushmount is a simple 2-piece interlocking hanger; invisible when installed. It is ingeniously designed to support or stabilize objects of practically all sizes and weights. Made of 16 gauge quality CR steel plated.

- Upholstered boards
- Head boards
- Boothbacks
- Paneling
- Bulletin boards
- Shelves
- Wall cabinets
- Wall accessories

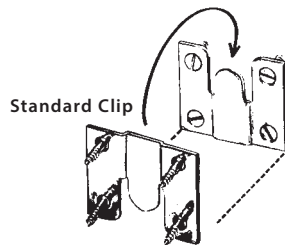

The Standard Interlock Clip fits precisely into mating hanger.

The Adjustable Interlock Clip has a 3/8" side clearance. Easy to line up, plenty of room to locate into mating hanger.



Standard Clip



Adjustable Clip

	PAIR	10 PAIR	50 PAIR	100 PAIR
Standard Clip <i>per pair</i>	3.90	3.30	3.00	2.60
Adjustable Clip <i>per pair</i>	3.90	3.30	3.00	2.60

POLY-FURNITURE COVERS

*Give your work the professional look!
Keep shipping smudges down.
1.0 Mil clear plastic covers
42" High covers*



	ACTUAL LENGTH	EACH	25/RL	100/RL	200/RL
28" Chair	54"	3.58	46.50	118.00	224.00
42" Chair	72"	3.70	51.00	130.00	248.00
60" Love Seat	92"	4.04	61.00	164.00	312.00
116" Sofa	148"	5.10	90.50	270.00	520.00

WELT FEET

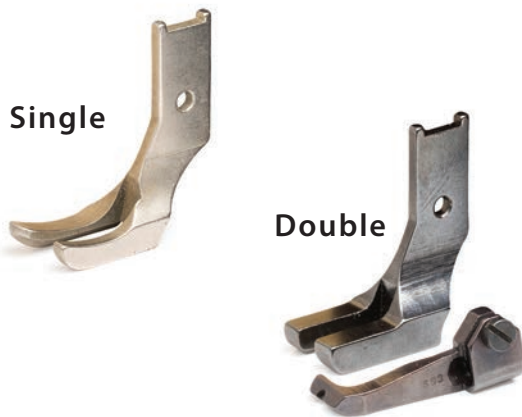

TYPE	6/32	8/32
Single	157.00	157.00
Double	157.00	157.00

LUBRICANT

FOR AIR STAPLE GUNS

- Put three drops in your gun's air supply line daily to keep it functioning properly.
- For heavier useage, put three drops in your gun's air supply line twice a day.



Pneumatic Tool Oil Lubricant 8oz 13.80

BOBBINS

TYPE	SIZE	EACH
"A"	1" x 1/4"	4.00
"G"	1" x 3/16"	4.00
"M"	1" x 3/8"	5.00



OIL

FOR SEWING MACHINES

- 4oz Put-Up Plastic Dispenser Bottle
- Quart Put-Up Clear Plastic Bottle



Sewing Machine Oil 4oz 5.80 QUARTS 14.99

WOVEN CANE

24" WIDE ROLLS

FINE-FINE 7/16"

FINE 1/2"

MEDIUM 5/8"

COMMON 3/4"

RADIO FINE



		FOOT	10 FT	25 FT	50 FT
Fine Fine	per foot	23.80	21.40	20.40	19.40
Fine	per foot	18.30	15.90	14.90	13.90
Medium	per foot	18.30	15.90	14.90	13.90
Common	per foot	18.60	16.20	15.20	14.20
Radio Fine	per foot	18.60	16.20	15.20	14.20

SPLINE

- SOLD IN FULL LENGTHS - PRICED PER FOOT
- APPROXIMATELY 10 TO 12 FOOT PIECES



	10' PCS	100'		No. 7	No.8	No.9	No.10
Spline: No 7	.74	.40	Height	7/64"	5/32"	3/16"	15/64"
Spline: No 8	.82	.48	Width	5/32"	3/16"	7/32"	9/32"
Spline: No 9	.88	.54					
Spline: No 10	1.00	.66					

PATTERN CHIPBOARD

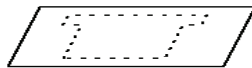

Sheet Size: 36" x 48" Thickness .030 Weight: 1LB 7oz

PER SHEET	SHEET	10 SHEETS	25 SHEETS	50 SHEETS
	4.98	3.18	2.90	2.70

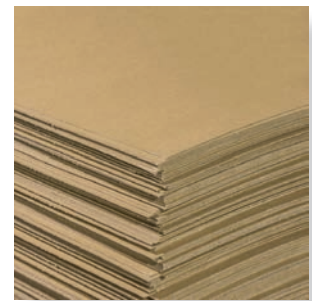

PATTERN PAPER

50 LB KRAFT PAPER Color: Brown Weight: 63 Lbs

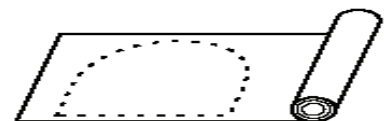

PER ROLL	WIDTH	DIA	FT/RL	ROLL
	48"	9"	972'	164.50

See Page 116 for Panel Chipboard

STYLE
9940

RAYON SCROLL GIMP

A 1		C 22		E 24		L 41		M 53	
B 1		C 23		E 29		L 44		M 56	
C 2		C 25		H 7		L 46		P 5	
C 3		C 29		J 4		L 48		PR 2	
C 5		D 1		J 11		L 49		PR 3	
C 6		D 3		J 15		L 50		PR 7	
C 7		D 5		J 16		L 52		PR 8	
C 11		D 24		J 18		L 58		PR 10	
C 12		D 25		J 19		L 60		PR 11	
C 14		E 3		J 23		L 79		PR 15	
C 15		E 11		K 33		M 17		PR 21	
C 16		E 14		K 35		M 42		R 1	
C 17		E 15		K 50		M 45		S 21	
C 19		E 16		L 26		M 51		YG 2	
C 21		E 18		L 28		M 52			



SCROLL GIMP

YARD 3.42
36 YD 51.12



**FRENCH GIMP
SPECIAL ORDER**

36 YD 69.84

MIDWEST DUCK

#4

- 100% Cotton • Color: Natural
- Weight: 24 oz. per square yard
- Finish: None applied

Width: 48"	YARD	10 YDS	20 YDS	50 YDS
	34.30	30.30	28.30	26.30



#6

- 100% Cotton • Color: Natural
- Weight: 22 oz. per square yard
- Finish: None applied

Width: 36"	YARD	10 YDS	20 YDS	50 YDS
	18.40	14.40	12.40	10.40
Width: 60"	25.20	21.20	19.20	17.20

Suggested Uses:

- Heavy bags
- Aprons
- Table covers
- Re-enactment Civil War Tents



#8

- 100% Cotton • Color: Natural
- Weight: 18 oz. per square yard
- Finish: None applied

Width: 48"	YARD	10 YDS	20 YDS	50 YDS
	20.50	16.50	14.50	12.50
Width: 60"	26.30	22.30	20.30	18.30

Suggested Uses:

- Aprons • Tool holders • Bags
- Murals • Roofing • Floor covering
- Director chairs

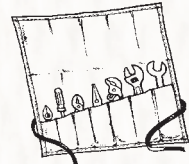

#10

- 100% Cotton • Color: Natural
- Weight: 14 oz. per square yard
- Finish: None applied

Width: 36"	YARD	10 YDS	20 YDS	50 YDS
	16.10	12.10	10.10	8.10
Width: 48"	18.50	14.50	12.50	10.50

Suggested Uses:

- Bags • Laundry Carts • Director chairs
- Floor Covering • Murals • Roofing

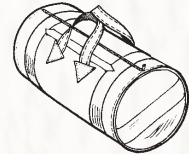

#12

- 100% Cotton • Color: Natural
- Weight: 12 oz. per square yard
- Finish: None applied

Width: 72"	YARD	10 YDS	20 YDS	50 YDS
	20.60	16.60	14.60	12.60

Suggested Uses:

- Filters
- Heavy bags
- Table covers
- Painters canvas
- Conveyor belts

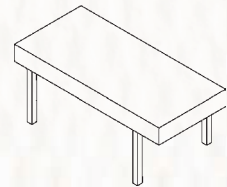

STA-SOF #10 COVER DUCK

- 100% Cotton • Color: Olive Drab (*direct dyed*)
- Width: 60"
- 14 oz. per square yard
- Water resistant • Pliable (*stays soft in cold climate*)
- Dry finish - will not rub off

Suggested Uses:

- Cot covers
- Winter cover for items stored outside.

Width: 60"	YARD	10 YDS	20 YDS	50 YDS
	36.70	32.70	30.70	28.70

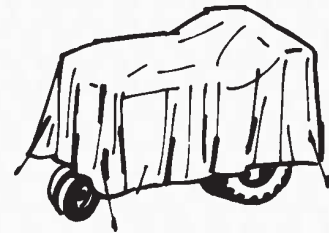

#8 CHAIR DUCK

- 100% Cotton • Vat colors
- Width: 58" • Extra heavy
- Weight: 18 oz. per square yard
- Water and mildew resistant

Suggested Uses:
Directors chairs
Hide-a-beds
Deck pads
Cots

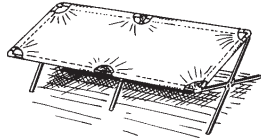

Colors	YARD	10 YDS	20 YDS	50 YDS
Reds	52.80	48.80	46.80	44.80
	59.50	55.50	53.50	51.50

BANTEX: WHITE

- Color: White
- Widths: 36" and 72"
- Weight: 10 oz. per square yard
- Smooth surface is ideal for printing

Suggested Uses:
• Outdoor banners • Pennants • Spa covers

(If required, please request a certificate of flame resistance.)



	YARD	10 YDS	25 YDS	50 YDS
Width: 36"	22.10	18.10	16.10	14.10
Width: 72"	24.80	20.80	18.80	16.80

POOLTEX: SWIMMING POOL COVER FABRIC

- Polypropylene mesh-knit
- Colors: Black / Green
- Widths: 72" / 73"
- Weight: 4.1 oz. per sq. yd.
- Specially designed for pool covers
- Lightweight - easy to handle and fabricate
- Resists alkalies and acids
- Sun and mildew resistant

(For heavy duty pool covers where mesh is not desired, coated vinyls or laminates are recommended.)

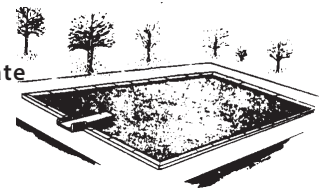

	YARD	10 YDS	20 YDS	50 YDS
Width: 73"	46.50	42.50	40.50	38.50

UTILITY TRASH TARP FABRIC

- Woven Polyester, open mesh
- Color: Multi-Color
- Finish: Vinyl encapsulated
- Width: 70" / 72"
- Weight: 12 oz. lineal yard
- 100 yards per roll

Ideally suited for trash truck covers and tarpaulins where rain or moisture protection is not required. Used to secure truckload contents against littering of roadways from fall-out or blow-off. This material may be sewn together or bonded and is highly abrasion and UV ray resistant.



	YARD	20 YDS	50 YDS	100 YDS
Width: 70" / 72"	23.80	19.80	17.80	15.80

TOLL-FREE
TOLL-FREE

CHICAGO
MILWAUKEE

800-728-4567
800-347-3603

773-582-5400
414-462-9220

HYDROTUFF: POLYESTER FABRIC

BLACK

- 600DN x 450DN on PVC
 - Color: Black
 - Width: 58"/59"
 - 50 yards per roll
- Ideally suited for:
- Backpacks
 - Banners
 - Sporting goods
 - Toiletry bags
 - Pouches
 - Tote bags
 - Pennants
 - Gym bags
 - Pizza bags
 - Golf Bags
 - Garment bags
 - Purse liners

Width: 58"/59"	YARD 12.00	25 YDS 9.00	50 YDS 7.40	<i>Other colors available 50 yard minimum</i>
----------------	----------------------	-----------------------	-----------------------	---

BILLIARD POOL TABLE FELT CLOTH

- 75% Wool, 25%Nylon
- Width: 66"
- Weight: 21 oz. per square yard

COLORS:
DARK GREEN
BURGUNDY

TOP QUALITY



Width: 66"	YARD 74.60
------------	----------------------

FISH SHANTY CANVAS

- 50% Polyester / 50% Cotton
- Color: Black
- Width: 64"
- Weight: 12 oz. Per Sq. Yd.
- Pigmented Vinyl Coated
- Flame Retardant-CPA1 84

An opaque flame retardant fabric, specially coated to allow moisture vapor transmission.

Ideally suited for camping tents and ice fishing shantys.

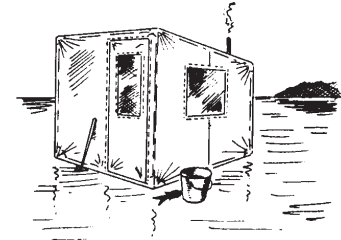

Width: 64"	YARD 23.60	25 YDS 21.60	50 YDS 19.60
------------	----------------------	------------------------	------------------------

HEALTHCARE FABRICS

"Comfort-Tick is a Polyurethane coated Polyester Knit that is ideal for wheel chair and rehab cushions. Fabrics has excellent memory and low shear characteristics. Provides an exceptional support surface for patients that are prone to decubital ulcers.

"Soft-Tick" is a PVC coated 70D Nylon suitable for general hospital mattress cover.



	WD	YDS/RL	CUTS	25 YDS	50 YDS	100 YDS
Comfort-Tick	56"	100	26.70	20.50	19.40	18.40
Soft-Tick	58"	100	22.30	16.10	15.00	14.00

CORDURA[®] NYLON: BLACK and CAMOUFLAGE

Other Colors Available

CORDURA Nylon is a versatile nylon fabric with more strength and bulk than No. 7 Duck, at little more than half the weight. Cordura Nylon is made from high tenacity nylon fiber lending a natural spun-like appearance, with excellent resistance to fading, abrasion, rot and mildew. Also very quick drying and highly water repellent.

Suggested Uses: Courier bags • insulated food service carriers • gun cases • stuff bags • "motocross" bicycle handlebar covers • motorcycle pants and reinforcements • airplane seat upholstery • camera bags • wallets duffle bags • soft sided luggage • purses, handbags • horse blankets • police, air and sea rescue supply bags surfboard/ski carryings bags • casino money bags • briefcases • backpacks • promotional items • beverage container covers • key fobs • scuba diving equipment • water ski vests • exercise equipment • children's large play balls • sporting goods • equipment and fishing harnesses



	YARD	10 YDS	50 YDS
Black	45.80	41.80	39.80
Camouflage	51.60	47.60	45.60

- 1000 Denier Nylon
- Width: 59"
- Weight: 11 oz. per sq. yd.
- Finish: Urethane coated

CAR COVER SUNTAN FLANNEL

- 100% Cotton
- Width: 56"
- Weight: 8 oz.
- Mildew resistant
- Water repellent
- Ideal for car and boat covers where soft flannel is needed to reduce marring of finishes.
- Recommended for indoor storage only.

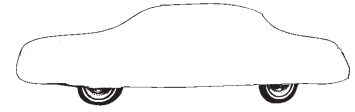

Width: 56"	YARD	10 YDS	30 YDS	50 YDS
	18.60	17.60	15.90	15.40

NO-SEE-UM POLYESTER SCREENING

- GRAY POLYESTER NETTING
 - Width: 72"
 - Finish: None
 - 100 yards per roll
 - Excellent flexing action
 - Tight construction prevents even the smallest bugs from entering enclosure
- Uses:** Tent windows • Mosquito netting • Add-a-Room

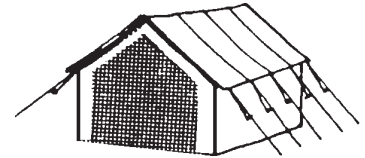

Width: 72"	COLOR	SCREEN	YARD	10 YDS	30 YDS	100 YDS
	Grey	18 x 16	25.00	21.00	19.00	17.00

FIBERGLASS SCREENING

- FIBERGLASS SCREENING E330 F
 - FIRE RETARDANT CPAI-84
 - Not effected by salt air, smoke or fumes
 - 33 yards per roll
 - Very strong and does not shrink or stretch
 - Will not support combustion
(Not recommended for pool covers)
- Uses:** Windows • Doors • Tents • Mosquito netting

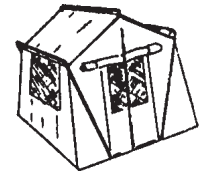

Width: 48"	COLOR	SCREEN	YARD	10 YDS	33 YDS
Width: 72"	Silver/Grey	18 x 14	22.50	18.50	16.50
	Silver/Grey	18 x 14	28.90	24.90	22.90

NYLON PACK CLOTH: SOLIDS

- 100% Nylon
 - 420 Denier
 - Weight: 62 oz. lineal yard
 - Not effected by rot or mildew
 - Heat set for excellent dye fastness
 - ¾ oz. coating of urethane for superior water repellency
- Suggested uses:**
- Rainwear • Sport bags
 - Hunting and fishing vests
 - Windsocks
 - Life vests, Backpacks
 - Luggage



STOCKED COLORS

BLACK
BONE
WHITE
KELLY GREEN
SILVER
RED

SPECIAL ORDER

(Allow 2 to 4 extra days)

ROYAL BLUE
NAVY
ORANGE
YELLOW
BROWN
LILAC
GRAPE
BURGUNDY
BEIGE

Width: 60"	YARD	10 YDS	25 YDS	50 YDS
	35.10	31.10	29.10	27.10

NYLON PACK CLOTH: CAMOUFLAGE

- 100% Nylon
 - 400 Denier
 - Weight: 62 oz. lineal yard
 - Not affected by rot or mildew
 - Heat set for excellent dye fastness
 - ¾ oz. coating of urethane for superior water repellency
- Suggested uses:**
- Rainwear • Sport bags
 - Hunting and fishing vests
 - Airplane covers,
 - Life vests, Backpacks
 - Luggage • Windsocks, etc.

CAMOUFLAGE COLORS

AUTUMN
SPRING



Width: 58"/60"	YARD	10 YDS	25 YDS	50 YDS
	29.50	25.50	23.50	21.50

TWILIGHT

Manufactured with **PRODURATECT™ S**
"A POPULAR SPA COVER VINYL!"

ENDURATEX™
INNOVATIVE VINYL S

FINISHES and TREATMENTS:

- Heat sealable
- Cold Crack -10 F°
- Mildew resistant: backing and face
- UV stabilized pigments: 500 hours minimum
- Anti-bacterial and anti-microbial

SPECIFICS:

- Width: 54"
- Weight: 28 ozs.
- Thickness: 0.97mm
- 40 yard roll

Cleaning Instructions:

This product should be cleaned with mild soap and water. Do not use alcohol based cleaners!

TWI 5519 WALNUT

TWI 5510 SPICE

Width: 54"	YARD	10 YDS	20 YDS
	20.50	17.00	13.90

HAARTZ® TONNEAU COVER

HAARTZ

- For full size trucks without a seam.
- Durable Polyester Vinyl Truck Bed Cover Fabric

INSTRUCTIONS FOR MAXIMUM PERFORMANCE:

- Cover must be secured at all points when vehicle is in motion.
- An unsecured cover will "wind-whip", resulting in damage to the vinyl fabric.
- Covers removed completely in temperatures below freezing will be difficult to resecure.



#1402 BLACK

Width: 78"	YARD	10 YDS	25 YDS	50 YDS
	28.80	27.80	26.30	24.30

ADVANTAGE 18 MEDIUM DUTY

Vinyl coated polyester PVC fabric specifically developed for truck covers, mats, and tarpaulins.

advantage¹⁸

TECHNICAL DATA:

- Vinyl coated polyester
- High tensile strength: 450 x 450 pounds (ASTM D5034)
- High tear strength: 85 x 85 pounds (ASTM D2261)
- Adhesion: 25 lbs / 2" (ASTM D751)
- Low temperature: -30° F (FS 5874 / ASTM D2136)
- Resistant to UVR: UV pigments
- Anti-mildew treated
- Heat sealable • Waterproof

SPECIFICS:

- Finish: Matte • Count: 20 x 20
- Width: 61" • 75 yards per roll
- Yarn: 1000 D Polyester x 1000 D Polyester
- Weight: 18 oz. per sq. yd.

TYPICAL APPLICATIONS:

- Truck covers
- Tarpaulins
- Construction curtains
- Pond liners • Mat covers
- Swimming pool covers
- Concrete curing blanket
- Flexible container bag
- Agricultural cover
- Pontoon boat covers
- Shelters • Dock seals
- Athletic products
- Machinery covers
- And many more!

COLORS:

- | | |
|------------|------------|
| RED | BROWN |
| GREY | TAN |
| BLACK | PURPLE |
| WHITE | PINK |
| GREEN | BURGUNDY |
| ROYAL BLUE | LIME GREEN |
| YELLOW | LIGHT BLUE |
| ORANGE | NAVY |

McDonald's Playland colors:
PURPLE • PINK • BURGUNDY

Width: 61"	YARD	20 YDS	75 YDS
	22.50	19.30	17.50

ADVANTAGE 22 HEAVY DUTY

Vinyl coated polyester PVC fabric specifically developed for truck covers, mats, and tarpaulins.

advantage²²

TECHNICAL DATA:

- Vinyl coated polyester
- High tensile strength: 400 x 400 pounds (ASTM D5034)
- High tear strength: 132 x 143 pounds (ASTM D2261)
- Adhesion: 28 lbs / 2" (ASTM D751)
- Hydrostatic resistance: 881 lbs/sq inch (ASTM D751)
- Mullen Burst: 924 LBS/SQ. Inch (ASTM D3786)
- High temperature: 176° F continuous, 200° F intermittent
- Low temperature: -40° F (FS 5874 / ASTM D2136)
- Abrasion, puncture and tear resistant
- Abrasion: start 250, complete 400 cycles (FS 5306 / ASTM D3884)
- Resistant to UVR: UV pigments
- Anti-mildew treated • Heat sealable • Waterproof

SPECIFICS:

- Finish: Matte • Count: 16 x 16
- Width: 61" • 75 yards per roll
- Yarn: 1500 D Polyester x 1500 D Polyester
- Weight: 22 oz. per sq. yd.

- **EXTREMELY DURABLE**
- **HIGH TENSILE AND TEAR STRENGTH**

TYPICAL APPLICATIONS:

- Truck covers
- Tarpaulins
- Construction curtains
- Pond liners • Mat covers
- Concrete curing blanket
- Flexible container bag
- Agricultural cover
- Swimming pool cover
- Pontoon boat covers
- And many more!

COLORS:

- BLACK
- BLUE
- GREEN
- GREY
- RED
- YELLOW
- WHITE
- TAN

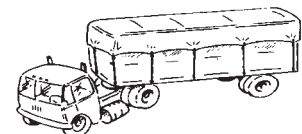

Width: 61"	YARD	25 YDS	75 YDS
	30.30	27.10	25.30

SUNBRELLA®

Acrylic Marine Duck

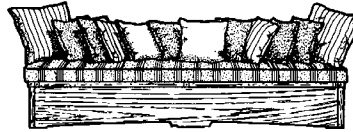

Suitable Applications:

- Marine use
- Umbrellas
- Boat cushions
- Tote bags
- Outdoor awnings
- Furniture cushions

**To protect your boat from the elements, you need SUNBRELLA!
The #1 marine fabric in the world!**

Above or below deck, Sunbrella fabrics are the smart choice for sail covers, biminis, dodgers, winch covers, cushions, interiors, curtains and more.

Fade-resistant Sunbrella fabrics protect your investment from salt water and all kinds of weather. Because it's woven, Sunbrella breathes, not trapping heat and moisture like vinyl. Vinyl can mildew, but Sunbrella looks great season after season. *In fact, Sunbrella fabrics are so durable we back them with the best limited warranty in the business!*

Every boater knows the inconvenience of mildew in close quarters. That's why Sunbrella is the boating world's choice for cushions and other cabin appointments. Available in a wide range of designs, textures, and weaves specifically created for marine decor. Sunbrella provides you with options suitable for a wide range of watercraft; from cocktail cruisers to fishing boats.

As you know, the right bimini top or cockpit enclosure will not only make your boat look great, it also provides crucial sun and weather protection for you and your crew. *Start your boating season earlier in the spring and end it later in the fall with a Sunbrella top!*

The elements can be hard on a boat, so to help you protect your investment and fully enjoy life on the water, Sunbrella has created a large range of specialty marine fabrics for any on-board application.



STOCKED COLORS

- 6001 PACIFIC BLUE
- 6003 JOCKEY RED (RED)
- 6004 NATURAL
- 6005 HEMLOCK TWEED
- 6007 CHARCOAL TWEED
- 6008 JET BLACK
- 6017 ROYAL BLUE (RED)
- 6018 WALNUT BROWN
- 6020 BEIGE
- 6026 NAVY
- 6030 CADET GRAY
- 6031 BURGUNDY (RED)
- 6037 FOREST GREEN
- 6043 PERSIAN GREEN
- 6044 CHARCOAL GREY
- 6046 CAPTAIN NAVY
- 6051 SILVER
- 6054 LINEN TWEED

SPECIAL ORDER

(Allow 2 to 4 extra days)

- 4613 BROWN
- 4614 TAN
- 4616 MOCHA
- 6021 TRUE BROWN
- 4622 TERRA COTTA (RED)
- 6023 AQUAMARINE
- 4624 SKY BLUE
- 4627 SALMON (RED)
- 4628 TOAST
- 4629 VANILLA
- 6033 LINEN
- 4635 BUTTERCUP
- 4638 CORAL (RED)
- 4639 MAUVE (RED)
- 4640 BLACK CHERRY (RED)
- 4641 SAPPHIRE BLUE
- 6042 OYSTER
- 6045 SEA GRASS GREEN
- 6047 PERSIAN TWEED
- 6048 TAUPE
- 6049 PLUM (RED)
- 6050 TEAL TWEED
- 6052 MEDITERRANEAN
- 6053 MEDITERRANEAN TWEED
- 4655 ALPINE
- 6066 LOGO RED (RED)
- 6067 MAHOGANY (RED)
- 2587/60 MULLED BERRY (RED)
- 2589/60 RODEO RED (RED)

SPECIAL ORDER

(Allow 2 to 4 extra days)

- 6000 ERIN GREEN
- 6002 SUNFLOWER (RED)
- 6006 DUBONNET TWEED (RED)
- 6009 ORANGE (RED)
- 6010 TURQUOISE
- 6011 SEA SPRAY

Color cards are available!

SPECIFICS

- Width: 46" or 60" where indicated
- Weight: 9.25 ozs. per square yard
- Solution dyed to give excellent fade and weather resistance

	YARD	15 YDS	25 YDS	50 YDS
SUNBRELLA - COLORS Width: 46"	48.00	44.00	42.00	40.00
SUNBRELLA - REDS Width: 46"	53.60	49.60	47.60	45.60
SUNBRELLA - COLORS Width: 60"	55.60	51.60	49.60	47.60
SUNBRELLA - REDS Width: 60"	62.60	58.60	56.60	54.60

Hi-Tech Fabric Guard #303
The only repellency treatment recommended by and for Sunbrella!
(See page 109)

Acrylic Binding available on next page.

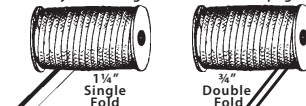

Because Sunbrella patterns and colors are changed frequently, please call for availability.

SPECIAL ORDER

- Awning Fabric: Colors
- Furniture Fabric: 5400 Solids
- Furniture Fabric: 5400 Reds
- Specialty Weaves: 8000
- Specialty Weaves: 8000 Reds
- Specialty Weaves: 8300
- Richard Frinier Collection - 32000
- Furniture Fabric: Stripes 56000
- Furniture Fabric: Stripes 5600

- Call For Pricing
- Call For Pricing
- Call For Pricing
- Call For Pricing
- Call For Pricing
- Call For Pricing
- Call For Pricing
- Call For Pricing
- Call For Pricing
- Call For Pricing

SPECIAL ORDER

- Jacquards: 45099
- Jacquards: 7253
- Rib: 7700
- Highpoint Collection - 40000
- Highpoint Collection - 42000
- Highpoint Collection - 44000
- Highpoint Collection - 45000
- Highpoint Collection - 47000
- Shadow: 51000

- Call For Pricing
- Call For Pricing
- Call For Pricing
- Call For Pricing
- Call For Pricing
- Call For Pricing
- Call For Pricing
- Call For Pricing
- Call For Pricing

SUNBRELLA PLUS®

SPECIFICATIONS

- Fabric: Woven solution dyed acrylic
- Finish: Face - fluorocarbon Back - polyurethane
- Width: 60"
- Weight: 10.0 oz. per square yard (ASTM-D-1682-86)
- Break Warp: 310 lbs. (ASTM-D-1682-64)
- Strength Fill: -170 lbs.
- Abrasion: (Wyzenbeek ASTM-D-3597-81, Sec. 7.5)
Face: Warp-Fill 75,000 cycles
Back: Warp-Fill 200,000 cycles
- Water: 110 cm
- Repellency: (Hydrostatic Pressure-AATCC 127-1985)
- NOT FIRE RETARDANT

FINISHES and TREATMENTS

- Highly moisture resistant
- Excellent abrasion resistance
- Dimensionally stable
- Bright and colorfast

COLORS

REDS

	WIDTH	YARD	25 YDS	50 YDS
	60"	81.10	77.10	75.10
REDS	60"	90.30	86.30	84.30

Acrylic Marine Duck

Made from the same high quality as the traditional Sunbrella fabric. Sunbrella Plus offers superior water resistance by utilizing a durable polyurethane undercoating. Sunbrella Plus can be used alongside regular Sunbrella® colors for coordinating marine applications when both water resistance and breathability are essential.

SUITABLE APPLICATIONS

- Canopies
- Biminis
- Dodgers
- Awnings
- Cockpit covers
- Travel covers
- Camper tops

SPECIAL ORDER

(Allow 2 to 4 extra days)

- 8401 PACIFIC BLUE
- 8403 JOCKEY RED (RED)
- 8404 NATURAL
- 8406 DUBONNET TWEED (RED)
- 8408 JET BLACK
- 8417 ROYAL BLUE
- 8423 AQUAMARINE
- 8430 CADET GREY
- 8431 BURGUNDY (RED)
- 8437 FOREST GREEN
- 8442 OYSTER
- 8443 PERSIAN GREEN
- 8446 CAPTAIN NAVY
- 8451 SILVER



This limited warranty is only valid if a copy of the invoice for the item purchased is submitted showing date of original purchase and covers fabric that has become unserviceable due to loss of color or strength from normal usage and exposure conditions; including sunlight, mildew and atmospheric chemicals. Consumer is responsible for normal care and cleaning of the fabric. This warranty covers fabric only. Glen Raven's liability is expressly limited to this warranty.

The coverage period is five (5) years for Sunbrella®, ten (10) years for Sunbrella Plus®, and five (5) years for Sunbrella Supreme® fabrics. This limited warranty covers five (5) years from the date of original installation. For the Sunbrella® marine interior fabrics, this limited warranty coverage three (3) years from date of original installation. Glen Raven will supply new fabric free of charge to replace fabric that has become unserviceable. You must call the dealer or retailer from whom you purchased the product to inspect the claim. They will contact the manufacturer of the item purchased. The manufacturer will then contact Glen Raven and secure replacement fabric for you.

SUNBRELLA CLEANING INSTRUCTIONS

Sunbrella® features a soil and stain resistant finish that makes clean-up a breeze. Spot wash by sponging briskly with a soapy solution of natural soap in lukewarm water. Rinse thoroughly with clean water to remove soap and air dry. For stubborn stains or suntan lotion, use a fabric spot remover. Follow directions on container. Rinse thoroughly with clean water, and air dry. Solution-dyed acrylic does not promote mildew growth, however, mildew may grow on dirt and other foreign substances that are not removed from the fabric. To clean mildew stains, prepare a mild solution of one cup bleach plus two capsful of a natural soap per gallon of water. Spray on entire area and allow to soak in. If necessary, scrub vigorously with a sponge or clean rag. Sponge thoroughly with clean water and let air dry. For a more extensive set of cleaning instructions, please contact your retailer.

ACRYLIC BINDING

Colors to match Sunbrella / Acrylic Marine Fabric

401 YELLOW	409 WHITE	417 CHARCOAL TWEED	4642 OYSTER
402 BURGUNDY	410 GREY	418 GREEN TWEED	4644 CHARCOAL
403 GREEN	411 TAN	419 TEAL	4646 CAPTAIN NAVY
404 BLUE/BLACK	412 NAVY	420 PERSIAN GREEN	4648 TAUPE
405 RED/BLACK	413 MAHOGANY	4604 NATURAL	4651 SILVER
406 BROWN	414 AQUA	4633 LINEN	4654 LINEN TWEED
407 BLACK	415 MAROON	4637 FOREST	
408 NAUTICAL BLUE	416 RED	4641 SAPPHIRE	

	YD/RL	YARD	ROLL	4 ROLLS
3/4" DOUBLE FOLD	50	4.44	102.00	97.00
1 1/4" SINGLE FOLD	50	4.76	118.00	113.00

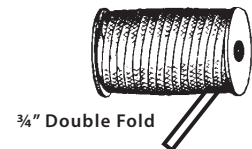
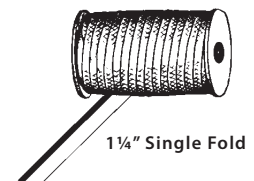

PHIFERTEX® CASUAL FURNITURE and AWNING FABRIC

- 100% woven vinyl coated polyester
- Protected with Microban®
- Width: 54"
- Weight: 11.3 oz per square yard
- 60 yards per roll
- Plain weave: 17 x 11
- CSFM Flame Retardant
- Lead Free
- Mildew, mold, and odor resistant
- Easily cleaned with mild soap & water
- GreenGuard certified
- Made in the USA

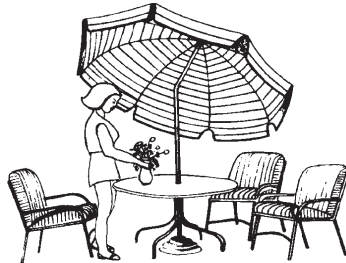

Great For:

- Umbrellas • Outdoor furniture
- Orthopedic equipment • Safety vests
- Upholstery • Breather and drainage panels



Width: 54"	YARD 42.20	10 YDS 38.20	25 YDS 36.20
------------	----------------------	------------------------	------------------------

PHIFERTEX®-PLUS

SPECIAL ORDER
ONLY 2-4 EXTRA DAYS!

DESIGNED ESPECIALLY FOR SLING
and UMBRELLA APPLICATIONS

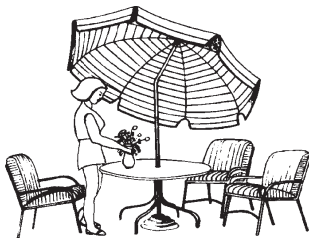

- 100% woven vinyl coated polyester
- Protected with Microban®
- Width: 54"
- Weight: 16 oz per square yard
- 60 yards per roll
- Tight weave: 42 x 14
- CSFM Flame Retardant
- Lead Free
- Mildew, mold, and odor resistant
- Easily cleaned with mild soap & water
- GreenGuard certified
- Complies with California TB #117
- Complies with MVSS-302
- Made in the USA

SOLID COLORS

- DUPIONE SPICE
- DUPIONI KIW
- DUPIONI POOLSIDE
- DUPIONI SAPPHIRE
- METALLICA PLATINUM
- METALLICA SMOKE
- METALLICA WHITE
- METALLICA SALSA
- METALLICA LAGOON
- STRAW MAT BLUE
- STRAW MAT COGNAC
- BURLAP
- WHITE
- GRAY SAND
- STUCCO
- SALSA
- SNAPPY
- YELLOW
- GARDEN GREEN
- HOLLY GREEN
- ROYAL BLUE
- NAVY PIER

STRIPES

- TEMPO STONE
- SKYLINE
- LEENA INDIGO
- WINSTED BEACH
- DELRAY KIW
- COASTLINE PEACOCK
- DELRAY POOLSIDE
- AQUAFINO
- WINDSOR SPA
- SANTIAGO
- PULSE DAHLIA
- DELRAY CONCH
- CHARISMA CITRUS
- RALEIGH WILLOW
- TRIXIE MYRTLE
- SAYLOR SEPIA
- BAILEY CITRONELLE
- BAILEY AQUA SHIMMER
- PALAZZO HARBOR
- OWEN SURF
- VINEYARD COPPER
- VINEYARD SILVER

TWEEDS

- TAFFY
- INDIGO
- CITRONELLE
- AQUA SHIMMER
- MADRAS HARBOR
- MADRAS SURF
- SPRING COPPER
- SPRING SILVER



METALLICA
PLATINUM

Width: 54"	YARD 52.50	10 YDS 48.50	25 YDS 46.50
------------	----------------------	------------------------	------------------------

TOP GUN®

- Width: 62"
- Weight: 11 oz. per square yard
- Acrylic impregnation
- Mildew and ultra-violet resistant
- Stay-True long lasting colors
- 100% Polyester high count woven base fabric
- Highly water repellent and breathable
- Stabilized maximum stretch or shrinkage less than 1%
- 4 Ply construction for superior wearability and toughness

TOP GUN Coated Polyester marine fabric is guaranteed for a five year period from date of original installation from excessive loss of color or strength during normal exposure conditions for marine top/cover applications. In the unlikely event of fabric failure, the manufacturer will supply the original owner with replacement TOP GUN fabric free of charge. Full terms of this product pledge are covered in the printed warranty.

Periodic cleaning with a solution of 4 ozs. of bleach and 2 ozs. of soap, NOT DETERGENTS, in one gallon of water is recommended to minimize accumulations of dirt and bird droppings, which can support surface mildew growth and cause fabric staining. Treatment with AQUA-TITE water repellent after cleaning may be required to restore the original level of water resistance.

NOT FLAME RESISTANT. DO NOT EXPOSE TO DIRECT FLAME OR EXTREME HEAT.

BASE FABRIC

- American made texturized Polyester Duck.
- High count provides outstanding tensile and tear strength, puncture resistance and dimensional stability.
- Four-ply construction for maximum wear and abrasion resistance.

COATING

- Specially formulated polymeric coating that will not harden, crack or peel after outdoor exposure, or when subjected to temperatures below 0°F.
- Highly water resistant, but permeable to water vapor.
- Will not trap excess moisture.
- Coating formulated to be resistant to mildew, sunlight, and atmospheric chemicals.

FINISHED FABRIC

- Highest Strength.
- Maximum abrasion-puncture resistance.
- Highly water resistant, yet breathable.
- Dimensionally stable, less than 1% shrinkage or elongation.

	YARD	10 YDS	25 YDS	50 YDS
COLORS Width: 62"	36.70	33.50	31.50	28.70
REDS Width: 62"	39.20	36.00	34.00	31.20

TOP GUN

- 458 CHARCOAL
- 459 TAUPE
- 461 SAND
- 462 AQUAMARINE
- 463 CARIBBEAN BLUE
- 464 ROYAL BLUE (RED)
- 465 HEMP BEIGE
- 466 TURQUOISE
- 467 SEA GULL GRAY
- 468 ARCTIC WHITE
- 469 BROWN
- 470 BUCKSKIN TAN
- 471 ONYX BLACK
- 472 IND BIRCH
- 473 HARBOR BLUE
- 474 NAVY BLUE
- 476 BURGUNDY (RED)
- 477 RED (RED)
- 478 TEAL
- 479 FOREST GREEN



AQUA-TITE™
Aqua-Tite Cleaner on page 109

TOP NOTCH

A REVOLUTIONARY NEW AWNING AND MARINE FABRIC

- Colorfast & UV resistant
- Luxurious appearance and feel
- Breathable
- Water, oil and soil repellent
- Strong, durable, and tear resistant
- Abrasion resistant
- Dimensionally stable
- Five year warranty



- Width: 60" Width
- Weight: 11.50 oz Per Sq. Yd
- 840 Denier Polyester Fabric
- Solution Dyed
- 50 yards per roll
- Hydrostatic, 8" for 10 minutes: 0
- Water repellency, spray rating: 100
- Tongue tear, lbs. warp x fill: 102.2 x 92.7
- Tensile strength, lbs. warp x fill: 732 x 432
- Fluorocarbon finish for UV resistance and color fastness

TOP NOTCH solution-dyed woven polyester has raised the bar on fabric availability for the awning and marine markets. TOP NOTCH is an advanced new hybrid of everything you want from both acrylic and polyester fabrics. This is the first time that all the best qualities of both acrylic and polyester fabrics have been combined into one product.

TOP NOTCH is an 840 Denier solution-dyed polyester fabric with a fluorocarbon finish that exhibits the color fastness and UV resistance long associated with solution-dyed acrylic fabrics. Yet, TOP NOTCH has the strength, durability, tear resistance, dimensional stability, and abrasion resistance of any premium quality polyester fabric. The fluorocarbon finish provides outstanding water repellency, oil and soil resistance, breathability, a luxurious hand and appearance.



- 559 TAUPE
- 563 BLUE
- 567 GRAY
- 570 TAN
- 571 BLACK
- 576 BURGUNDY (RED)
- 577 RED
- 579 FOREST GREEN
- 594 OCEAN BLUE
- 558 CHARCOAL
- 574 NAVY
- 577 RED (RED)
- 581 YELLOW (RED)

	YARD	10 YDS	25 YDS	50 YDS
COLORS	39.90	37.90	35.90	33.90
REDS	42.40	40.40	38.40	36.40



SUNFORGER® BOAT SHRUNK

GENERAL CHARACTERISTICS: **SUITABLE APPLICATIONS:**

- Practical, durable
- Superior strength
- 100% Cotton finish
- Easily cleaned
- Boat covers
- Tents
- Outdoor furniture covers
- Patio grill covers
- Awnings

FINISHES & TREATMENTS: **SPECIFICS:**

- Water repellent
- Mildew resistant
- Rot resistant
- Weather resistant
- Mineral dyed
- Width: 36"
- Weight: 12.65 oz. per sq. yd.
- 50 yards per roll

COLORS:

- 714145 KHAKI
- 714105 PEARL GRAY
- 714124 NATURAL



100% COTTON

Sunforger Boat Shrunken is a durable water-repellent and mildew resistant fabric with an added feature; an exposure shrinkage of approximately 3% or less under normal use.

A popular fabric for where normal water and moisture exist!

Width: 36"	YARD	10 YDS	25 YDS	50 YDS
	29.40	25.40	21.40	20.50

AQUALON® EDGE

Aqualon Edge, the next generation of multi-use, high quality marine cover fabric. Powered by cutting-edge Perfecta Marine® technology, Aqualon Edge reduces heat gain, keeping surface and interior temperatures cooler.

- Width: 60"
- Weight: 9 ounces per square yard
- Two-ply polyester duck; topside is double-coated with a pigmented vinyl resin and underside with a durable water resistant clear finish
- Excellent dimensional stability
- Remains flexible in all climates
- Resistant to mildew, abrasions, water penetration, most petroleum products, ultra-violet rays and a wide range of acid and alkaline liquids
- Color will not rub off
- Will not crack, peel or harden

COLORS:

- | | |
|-----------------|---------------------|
| 5500 BLACK | 5517 WHITE |
| 5503 FOREST | 5518 CHARCOAL |
| 5504 TEAL | 5522 METALLIC BLACK |
| 5507 RED | 5528 NAVY |
| 5508 IVORY | 5541 AQUAMARINE |
| 5509 BURGUNDY | 5542 SILVER |
| 5510 DARK BROWN | 5549 TAN |
| 5511 TURQUOISE | 5550 PEARLESCENT |
| | 5557 ULTRA WHITE |
| | 5562 METALLIC BLUE |
| | 5564 METALLIC NAVY |



Width: 60"	YARD	25 YDS	50 YDS
	39.00	35.00	33.00

WHICH BOAT COVER FABRIC TO USE?

SUNBRELLA® - ACRYLIC

Beautiful colors with the ability to stay "new looking", for the longest possible time. NO color rub-off, largest variety of colors available, and is the most fade resistant of all boat cover fabrics. Requires more care by the boat owner than with other fabrics. With proper care, it has a useful lifespan longer than the others and remains attractive for a much longer time period; guaranteed not to fade or mildew for five (5) years. Abrasion resistance is not as high when compared with the others. Unlike cotton, this has a tendency to stretch slightly, but does not shrink. Reinforcements in the contact areas with the boat, and a method of tie-down with provisions for tightening down the cover and taking up the "slack" are necessary. The boat owner must be made aware of their responsibility to keep the cover tight if they are towing it down the road. Wind-whipping can be most detrimental. With this in mind and proper care, this acrylic fabric will last longer and look better over a longer period of time and may cost less in the long run. It may be necessary to retreat the fabric for water repellency every few years to maintain utmost service, during its' long life span.

SUNFORGER® - 100% COTTON

("Vivatex" and "Marineshrunk") - Most economical, short-term solution. Water repellency can not be beaten by the best synthetic alternatives with good abrasion resistance and best general overall service throughout the life of the fabric. Colors are limited to muted mineral dye shades. Life expectancy, with good care, will be about 1/2 to 2/3 that of the synthetics. Also more adversely effected than synthetics by tree sap, bird droppings, acid rain, etc.

TOP GUN - AQUALON POLY BOAT DUCK

Aqualon is the toughest, strongest & most abrasion resistant of the three, also, more stable with regard to stretching or shrinking, requiring less care than the others. Available in many desirable colors, however, color is more likely to fade over the first few years, and "crocking" or "color rub-off", can be a concern, especially upon contact with vinyl seats, etc. When it comes into contact with vinyl upholstery, etc., a protective patch of cotton or vinyl should be sewn underneath. Water repellency is not as high (or consistent) as the others over the long term. For the boat owner who does not want to take care of their cover, this type fabric is as tough as nails and should be considered.

SPECTROPILE LX[®] AUTO • MARINE CARPET

72" non-woven polyester!
Dries faster than tufted carpet!

- 100% FOSSFIBRE[®] solution-dyed polyester fibre for consistent color, maximum color fastness, and high UV resistance
- High heat resistance - superior to polypropylene
- Exceptionally lush, uniform appearance with no linear pattern
- Will not fray or unravel
- High resistance to chemicals including hydrocarbons, salts, acids and alkalis
- Resists mold and mildew
- Resists staining and soiling
- Custom colors available
- Custom widths available
- 60 lineal yard rolls

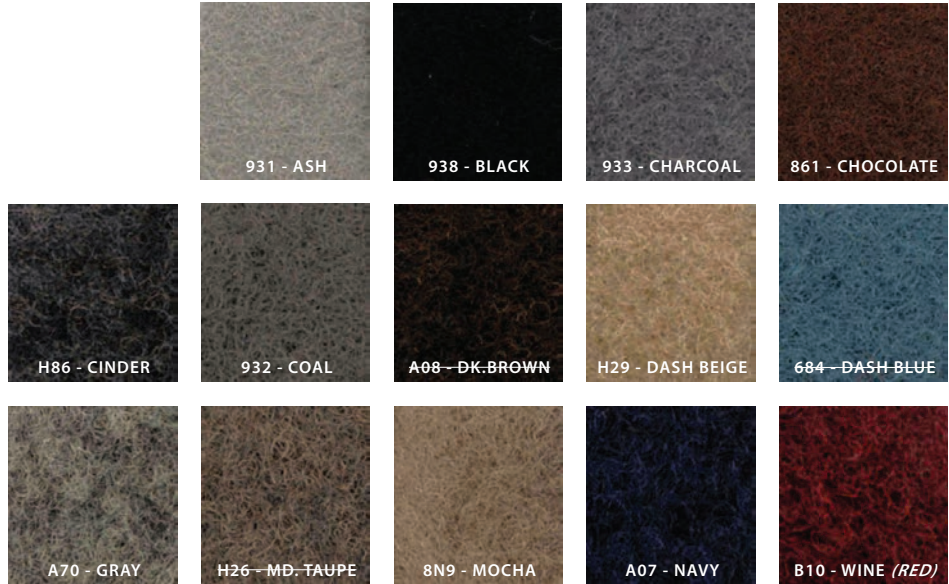

	YARD	10 YDS	25 YDS	50 YDS
COLORS: per yard	36.20	32.40	30.40	28.80
REDS: per yard	37.90	34.10	32.10	30.50

Discontinued: Call for availability

FOSS[®] SEATING AUTO • MARINE CARPET



Width: 60"	YARD	10 YDS	25 YDS	50 YDS
	33.00	29.20	27.20	25.60

FOSS[®] FLOORING AUTO • MARINE CARPET

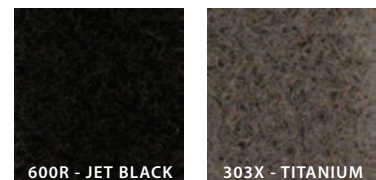

Width: 60"	YARD	10 YDS	25 YDS	50 YDS
	40.80	37.00	35.00	33.40

MARINE HEADLINER

MANUFACTURED TO MEET THE FOLLOWING CODES:

- California Tech Bulletin #117
- Motor Vehicle Safety Standard 302
- Marine Cold Crack: -10°F
- Mildew resistant backing and face
- Marine UV stabilized pigments

SPECIFICS:

- Width: 54" (137cm)
- Weight: 21 oz.
- Roll Size: 50 yard roll

CLEANING

- Clean with mild soap and water.
- Do not use alcohol based cleaners



- | | |
|------------|----------------------|
| HDL-1004 | MARINE PERF WHITE |
| HAP-2616-A | HAMPTON PERF SNOW |
| HAP-6439-A | HAMPTON PERF GRANITE |
| HAP-6508-A | HAMPTON PERF EBONY |

	YARD	10 YDS	30 YDS
Marine	32.40	27.30	23.50
Hampton	30.50	25.70	22.10



MARINE UNDERLINING

Seat and Cushion Underlining

- Base Fabric: 100% Polyester
- Weight: 9 oz. Per Lineal Yard
- Yards Per Roll: 100

- Breathable
- Mildew and Rot Resistant
- Dimensionally Stable



- | | |
|----------|--------------|
| MARU-001 | BLACK |
| MARU-002 | WHITE |
| MARU-003 | GREY |
| MARU-004 | BRIGHT WHITE |

Width: 54"	YARD	10 YDS	25 YDS
	17.00	14.80	14.10



BOAT WINDOWS: CLEAR VINYL

UVR TREATED

Style: with tissue

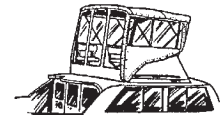

SUPER DOUBLE POLISHED CLEAR SPECIFICATIONS

Gauge	16	20	30	40	ASTM
Softness (PHR)	42	45	45	50	D-2240
Tensile Strength (PSI)	2980	2700	2400	2400	D-882-61
Elongation (%)	220	240	260	298	D-822-61
Tear Strength (LB/IN)	34	34	32	32.5	D-689
U. V. Rating (HOURS)	200	200	200	200	D-1790
Cold Crack (F°)	+0	+0	+0	+0	D-11204

	WIDTH	YDS/RL	YARD	10 YDS	ROLL
16 GAUGE	54"	25	16.70	14.40	12.40
20 GAUGE	54"	20	19.20	16.90	14.90
30 GAUGE	54"	15	33.60	31.30	29.30
40 GAUGE	54"	10	44.10	41.80	39.80

SOLARSCREEN PPS

Flexible PVC Pressed Polished Screen Sheets

- High UV Resistance
- Mildew Resistant
- Heat Weldable
- Privacy Screening
- Passes FMVSS-302
- High Tear Resistance

Now you can protect your interior from the sun's hottest UV rays while still maintaining visibility. Our soft hand, 50" x 100", 40 gauge Pressed Polished Window with encapsulated screens not only provide a high level of UV protection against both UVA and UVB rays, but also provide much sought after privacy. Black one side and white on the other. Specifically designed to be heat weldable, mildew resistant and withstand severe weather conditions. Excellent for marine, RV, Jeep, Golf Carts and outdoor enclosure applications

Sheets: 50" x 100"

**PER SHEET
300.00**

VINYL COLLECTION GUIDE

SPRADLING COLLECTION

	CATALOG PAGE	STOCK LOCATION	TYPE	YARDS PER ROLL	WT PER LN. YD.	WIDTH	COLD CRACK	MVSS 302	CAL 117	MILDEW RESIST	HEAT SEALABLE	PERMA BLOK ³	PERMA GUARD	NAPA FINISH
Allegro Soft	170	WI	PVC	30	27	54"	-10°F	Yes	Yes	Yes	Yes			
Apex Soft	170	WI	PVC	30	29	54"	-10°F	Yes	Yes	Yes	Yes	Yes		
Aries Soft	170	WI	PVC	30	29	54"	-10°F	Yes	Yes	Yes	Yes			
Atmosphere	170	WI	PVC	30	35	54"	-20°F	Yes	Yes	Yes	Yes			Yes
Beluga	171	WI	PVC	30	29	54"	-20°F	Yes	Yes	Yes	Yes		Yes	
Buckskin	171	WI	PVC	30	28	54"	-10°F	Yes	Yes	No	Yes			
Caprice	171	WI	PVC	30	28	54"	-10°F	Yes	Yes	No	Yes			
Cenery	172	WI	PVC	30	28	54"	-10°F	Yes	Yes	No	Yes			
Carbon Fiber	171	WI	PVC	30	29	54"	-10°F	Yes	Yes	Yes	Yes			
Corinthian Soft	172	WI	PVC	30	29	54"	-10°F	Yes	Yes	Yes	Yes			
Dolce	209	WI	PU	30	40	54"	-10°F	Yes	Yes	No	Yes			
EZ Vinyl	204	WI	PVC	40	25	54"	-10°F	Yes	Yes	No	Yes			
Flotilla II	172	WI	PVC	40	29	54"	-10°F	Yes	Yes	Yes	Yes			
G Grain	173	WI	PVC	30	29	54"	-10°F	Yes	Yes	No	Yes			
Gemini Soft	172	WI	PVC	30	29	54"	-10°F	Yes	Yes	Yes	Yes	Yes		
Grand Prix Soft	173	WI	PVC	30	29	54"	-10°F	Yes	Yes	No	Yes			
Heidi Soft	173	WI	PVC	30	29	54"	-10°F	Yes	Yes	No	Yes			
Heidi Soft Marine	173	WI	PVC	30	29	54"	-10°F	Yes	Yes	No	Yes			
Islander Soft	174	WI	PVC	30	29	54"	-10°F	Yes	Yes	Yes	Yes			
Longitude	174	WI	PVC	30	28	54"	-10°F	Yes	Yes	No	Yes			
Madrid Soft	174	WI	PVC	30	29	54"	-10°F	Yes	Yes	No	Yes			
Marlin	174	WI	PVC	30	29	54"	-10°F	Yes	Yes	Yes	Yes		Yes	
Milled Pebble	175	WI	PVC	30	29	54"	-10°F	Yes	Yes	No	Yes			
Montana Soft	175	WI	PVC	30	29	54"	-10°F	Yes	Yes	No	Yes			
Monticello Soft	175	WI	PVC	30	29	54"	-10°F	Yes	Yes	No	Yes			
Navigator Soft	175	WI	PVC	30	29	54"	-10°F	Yes	Yes	Yes	Yes			
Nuance	176	WI	PVC	30	26	54"	-10°F	Yes	Yes	Yes	Yes			Yes
Orion Soft	176	WI	PVC	30	29	54"	-10°F	Yes	Yes	No	Yes			
Oxen Soft	176	WI	PVC	30	28	54"	-10°F	Yes	Yes	Yes	Yes			
Patriot Plus II	177	WI	PVC	30	34	54"	-20°F	Yes	Yes	Yes	Yes	Yes		
Pegasus	178	WI	PVC	30	29	54"	-10°F	Yes	Yes	Yes	Yes			
Polaris	178	WI	PVC	30	29	54"	-10°F	Yes	Yes	No	Yes			
Prelude	178	WI	PVC	30	32	54"	-20°F	Yes	Yes	Yes	Yes	Yes		
Reflex	179	WI	PVC	30	32	54"	-20°F	Yes	Yes	Yes	Yes	Yes		
Renaissance	179	WI	PVC	30	34	54"	-20°F	Yes	Yes	Yes	Yes	Yes		
Ruffino	179	WI	PVC	30	28½	54"	-10°F	Yes	Yes	No	Yes			
Seabreeze Soft	180	WI	PVC	30	29	54"	-10°F	Yes	Yes	Yes	Yes			
Sierra Soft	180	WI	PVC	30	29	54"	-10°F	Yes	Yes	No	Yes			
Simtex	181	WI	PVC	30	29	54"	-10°F	Yes	Yes	No	Yes			
Soho	181	WI	PVC	30	28	54"	-10°F	Yes	Yes	No	Yes			
Stratosphere	181	WI	PVC	30	28	54"	-30°F	Yes	Yes	Yes	Yes	Yes		
Sutton	181	WI	PVC	30	28	54"	-10°F	Yes	Yes	No	Yes			
Torino	182	WI	PVC	30	28	54"	-10°F	Yes	Yes	No	Yes			
Trexx Met MQ	182	WI	PVC	30	28	54"	-10°F	Yes	Yes	Yes	Yes			
Verona	182	WI	PVC	30	28	54"	-10°F	Yes	Yes	No	Yes			
Wallaby Soft	182	WI	PVC	30	29	54"	-10°F	Yes	Yes	No	Yes			
Whisper	183	WI	PVC	30	27	54"	-20°F	Yes	Yes	Yes	Yes			Yes
Zander	183	WI	PVC	30	29	54"	-10°F	Yes	Yes	Yes	Yes		Yes	
5000 Marine White	204	WI	PVC	40	25	54"	-10°F	Yes	Yes	Yes	Yes			

ENDURATEX® COLLECTION

	CATALOG PAGE	STOCK LOCATION	TYPE	YARDS PER ROLL	WT PER LN. YD.	WIDTH	COLD CRACK	MVSS 302	CAL 117	MILDEW RESIST	HEAT SEALABLE	PROD-URATEC	FORBID
Armada	184	IL	PVC	40	30	54"	-10°F	Yes	Yes	Yes	Yes	Yes	
Aspirations	184	IL	PVC	30	26	54"	-10°F	Yes	Yes	Yes	Yes	Yes	
Berwick Tweed	185	IL	PVC	30	25	54"	-10°F	Yes	Yes	Yes	Yes	Yes	
British Sterling	185	IL	PVC	30	30	54"	-10°F	Yes	Yes	Yes	No	No	Yes
Brushed Aluminum	195	IL MI	PVC	40	35	54"	-10°F	Yes	Yes	Yes	Yes	Yes	
Carbon Fiber	186	IL MI	PVC	30	35	54"	-10°F	Yes	Yes	Yes	Yes	Yes	
Chain Maille	186	IL	PVC	30	30	54"	-10°F	Yes	Yes	Yes	Yes	No	Yes
Coastal Ranch	186	IL	PVC	30	30	54"	-10°F	Yes	Yes	Yes	Yes	Yes	
Crianza	187	IL	PU/PVC	30	34	54"	-20°F	Yes	Yes	Yes	Yes	No	
Corinthian	195	IL MI	PVC	30	30	54"	-10°F	Yes	Yes	Yes	Yes	Yes	
Counterpane	187	IL MI	PVC	30	29	54"	-10°F	Yes	Yes	No	Yes	No	
Eclipse	189	IL MI	PVC	30	30	54"	-10°F	Yes	Yes	Yes	Yes	Yes	
El Capitan	187	IL MI	PVC	20	44	54"	-40°F	Yes	Yes	No	Yes	No	
Doeskin	195	IL MI	PVC	30	30	54"	-10°F	Yes	Yes	Yes	Yes	Yes	
G Grain	195	IL MI	PVC	30	30	54"	-10°F	Yes	Yes	Yes	Yes	Yes	
Gran Reserva	188	IL	PU/PVC	30	34	54"	-10°F	Yes	Yes	Yes	No	Yes	
Grand Vista	188	IL	PVC	30	36	54"	-10°F	Yes	Yes	Yes	No	No	Yes
Hampton	195	IL MI	PVC	30	30	54"	-10°F	Yes	Yes	Yes	Yes	Yes	
Heidi	195	IL MI	PVC	30	30	54"	-10°F	Yes	Yes	Yes	Yes	Yes	
Honda	195	IL MI	PVC	30	30	54"	-10°F	Yes	Yes	Yes	Yes	Yes	
Independence II	189	IL MI	PVC	30	32	54"	-10°F	Yes	Yes	Yes	No	No	Yes
Jetstream	189	IL MI	PVC	40	30	54"	-10°F	Yes	Yes	Yes	Yes	Yes	
Kodiak II	203	IL MI WI	PVC	20	50	61"	-40°F	Yes	Yes	Yes	Yes	Yes	
Lighthouse	190	IL MI	PVC	40	28	54"	-10°F	No	No	Yes	No	No	
Longitude	191	IL	PVC	30	30	54"	-10°F	Yes	Yes	Yes	Yes	Yes	
Lunar	191	IL	PVC	30	26	54"	-10°F	Yes	Yes	Yes	Yes	No	
Luxor	195	IL MI	PVC	30	30	54"	-10°F	Yes	Yes	Yes	Yes	Yes	
Madrid	195	IL MI	PVC	30	30	54"	-10°F	Yes	Yes	Yes	Yes	Yes	
Mercedes	195	IL MI	PVC	30	30	54"	-10°F	Yes	Yes	Yes	Yes	Yes	
Milled Pebble	195	IL MI	PVC	30	30	54"	-10°F	Yes	Yes	Yes	Yes	Yes	
Montana	195	IL MI	PVC	30	29	54"	-10°F	Yes	Yes	No	Yes	Yes	
Monticello	195	IL MI	PVC	30	34	54"	-20°F	Yes	Yes	Yes	Yes	Yes	
Nissan	195	IL MI	PVC	30	29	54"	-10°F	Yes	Yes	Yes	Yes	Yes	
Ossie	191	IL	PVC	30	32	54"	-20°F	Yes	Yes	Yes	Yes	Yes	
Oxen	195	IL MI	PVC	30	30	54"	-10°F	Yes	Yes	Yes	Yes	Yes	
Paul Bunyon	204	IL MI WI	PVC	20	38	54"	-30°F	Yes	Yes	No	No	No	
Phantom	192	IL	PVC	30	30	54"	-10°F	Yes	Yes	Yes	Yes	Yes	
Prizm	192	IL	PVC	30	36	54"	-10°F	Yes	Yes	Yes	No	No	Yes
Promotional Blacks	204	IL MI WI	PVC	40	26	54"		No	No	No	No	Yes	
Rapper	203	IL	PVC	30	30	54"	-10°F	Yes	Yes	Yes	Yes	Yes	
Rapper Extreme	203	IL	PVC	30	29	54"	-40°F	Yes	Yes	Yes	Yes	Yes	
Sierra	195	IL MI	PVC	30	30	54"	-10°F	Yes	Yes	Yes	Yes	Yes	
Slipstop	203	IL	PVC	40	28	54"	-30°F	Yes	Yes	Yes	Yes	Yes	
Soho	192	IL	PVC	30	32	54"	-10°F	Yes	Yes	Yes	Yes	No	Yes
Surrey	193	IL	PVC	30	28	54"	-10°F	Yes	Yes	Yes	Yes	Yes	
Toyota	195	IL MI	PVC	30	30	54"	-10°F	Yes	Yes	Yes	Yes	Yes	
Tradewinds Plus	193	IL MI	PVC	40	32	54"	-10°F	Yes	Yes	Yes	No	No	Yes
Twilight	156	IL	PVC	40	28	54"	-10°F	No	No	Yes	Yes	Yes	
Vaquero	194	IL	PVC	30	30	54"	-10°F	Yes	Yes	Yes	Yes	No	
Verona	194	IL	PVC	30	32	54"	-10°F	Yes	Yes	Yes	No	No	Yes
Wallaby	195	IL MI	PVC	30	30	54"	-10°F	Yes	Yes	Yes	Yes	Yes	
Windsong 2	194	IL MI	PVC	40	32	54"	-10°F	Yes	Yes	Yes	No	No	Yes

VINYL COLLECTION GUIDE

BOLTAFLEX® COLLECTION

	CATALOG PAGE	STOCK LOCATION	YARDS PER ROLL	WT PER LN. YD.	WIDTH	COLD CRACK	MVSS 302	CAL 117	MILDEW RESISTANCE	HEAT SEALABLE	PRE-FIXX®
Colorguard	198	IL	30	36	54"	-20°F	Yes	Yes	No	Yes	Yes
Grand Sierra	198	IL	30	36	54"	-20°F	Yes	Yes	No	Yes	
Harmony	198	IL	30	36	54"	-20°F	Yes	Yes	No	Yes	
Levante	199	IL	50	22	54"	-20°F	Yes	Yes	Yes	Yes	
Capitano	200	IL MI	30	29	54"	-20°F	Yes	Yes	Yes	H.E.	

MORBERN® COLLECTION

	CATALOG PAGE	STOCK LOCATION	YARDS PER ROLL	WT PER LN. YD.	WIDTH	COLD CRACK	MVSS 302	CAL 117	MILDEW RESISTANCE	HEAT SEALABLE	PERMABLOK®
All Sport	202	WI	40	36	54"	-60°F	Yes	Yes	Yes	N/A	No
Allante	201	WI	40	29	54"	-25°F	Yes	Yes	Yes	N/A	No

SPECIALTY and MISCELLANEOUS VINYLs, and URETHANES

CHARACTERISTICS	PAGE	WH	PRODUCTS	CHARACTERISTICS	PAGE	WH	PRODUCTS
Convertible Topping	238	WI IL	Haartz Topping	Pleated Vinyls	180	WI	SeaQuest
Exotic Animal Patterns	197	IL	Urban Exotics	Promotional: Black	204	ALL	Based on Availability
Heavy Duty: Blacks	204	WI IL	Paul Bunyon	Recycled Leather	197	IL	Recast
Landau Topping	239	IL	Haartz Landau Vinyl Topping	Spa Covers	156	IL	Twilight
Marine Topping	160	WI	Haartz Boat Topping	Tarps	156	WI	Advantage 18 and 22
Nanocide Treated	201	WI	Dimensions	Tonneau Cover	156	WI	Haartz Tonneau Cover
				Urethanes	208	IL	Infiniss, Skintex

CULP COLLECTION

	CATALOG PAGE	STOCK LOCATION	TYPE	YARDS PER ROLL	WT PER LN. YD.	WIDTH	COLD CRACK	MVSS 302	CAL 117	MILDEW RESIST	HEAT SEALABLE	iClean
Cantina	196	IL	PU	30	22	54"	-10°F	No	Yes	Yes	N/A	
Castillo	196	IL	PU	30	26	54"	-10°F	Yes	Yes	No	N/A	Yes
Dillon	196	IL	PU	30	20.3	54"	-10°F	Yes	Yes	No	N/A	
Gunslinger	197	IL	PU	30	20.3	54"	-10°F	Yes	Yes	No	N/A	
Oregon Trail	197	IL	PU	30	20.3	54"	-10°F	Yes	Yes	No	N/A	

VINYL COLLECTION GUIDE

FAUX LEATHER COLLECTION

	CATALOG PAGE	YARDS PER ROLL	WT PER LN. YD.	WIDTH	COLD CRACK	MVSS 302	CAL 117	MILDEW RESISTANCE	HEAT SEALABLE	PRE-FIXX [®]
Infiniss	208	30	30	54"	-20°F	Yes	Yes	Yes	H.E.	Yes
Infiniss Distressed	208	30	30	54"	-20°F	Yes	Yes	Yes	Yes	No
Infiniss Dove	208	60	25	54"	-20°F	No	Yes	Yes	Yes	No
Infiniss Maya	208	60	25	54"	-20°F	No	Yes	Yes	Yes	No
Infiniss Murano	208	40	30	54"	-20°F	No	Yes	Yes	Yes	No
Infiniss Tuscany	208	30	30	54"	-20°F	Yes	Yes	Yes	Yes	No
Nuvtex Berretta	208	30	26	54"	-10°F	No	Yes	No	Yes	No
Nuvtex Big Bird	208	30	30	54"	-20°F	Yes	Yes	Yes	Yes	No
Nuvtex Croco	208	30	30	54"	-20°F	Yes	Yes	Yes	Yes	No
Nuvtex Gator	208	25	51	72"/75"	-20°F	No	Yes	Yes	Yes	No
Nuvtex Patent	208	30	30	54"	-20°F	Yes	Yes	Yes	Yes	No
Skintex Adante	208	30	26	54"	-20°F	Yes	Yes	Yes	H.E.	Yes
Skintex Essence	208	40	30	54"	-20°F	No	Yes	Yes	H.E.	Yes
Skintex Lychee	208	35	22	54"	-10°F	No	Yes	Yes	Yes	No
Skintex Lychee Metallic	208	30	30	54"	-20°F	Yes	Yes	Yes	Yes	No
Skintex Ostrich	208	30	30	54"	-20°F	Yes	Yes	Yes	Yes	No
Skintex Provence	208	30	30	54"	-20°F	Yes	Yes	Yes	Yes	No
Skintex Snake	208	30	30	54"	-20°F	Yes	Yes	Yes	Yes	No
Texuede Soave 500	208	30	32	54"	-20°F	Yes	Yes	Yes	Yes	N
Texuede 1000	208	30	30	54"	-20°F	Yes	Yes	Yes	Yes	No
Texuede Snake	208	30	34	54"	-20°F	Yes	Yes	Yes	H.E.	Yes
Texuede SP	208	30	30	54"	-20°F	Yes	Yes	Yes	Yes	No

H.E. - Heat Embossable, but not heat sealable.

NASSIMI COLLECTION

	CATALOG PAGE	STOCK LOCATION	YARDS PER ROLL	WT PER LN YD	WIDTH	COLD CRACK	MVSS 302	CAL 117	MILDEW RESISTANCE	HEAT SEALABLE
Symphony Classic	206	IL	40	29	54"	-20°F	Yes	Yes	Yes	No
Symphony San Remo	207	IL	30	36	54"	-10°F	Yes	Yes	No	No
Symphony Glaze	207	IL	30	36	54"	-10°F	Yes	Yes	No	No
Symphony Vintage	207	IL	30	36	54"	-10°F	Yes	Yes	No	No
New Soho	194	IL	40	28	54"	-20°F	Yes	Yes	Yes	Yes
Seaquest	180	MI	PVC	32	54"	-10°F	Yes	Yes	Yes	Yes

NAUGAHYDE COLLECTION

	CATALOG PAGE	STOCK LOCATION	YARDS PER ROLL	WT PER LN YD	WIDTH	COLD CRACK	MVSS 302	CAL 117	MILDEW RESISTANCE	HEAT SEALABLE
Chamea	201	IL	35	26	54"	-20°F	Yes	Yes	Yes	No
Allure	200	IL	35	26	54"	-20°F	Yes	Yes	Yes	No

CALIFORNIA'S PROPOSITION 65 - "PROP 65"

Chemical Fabrics and Film Association

Frequently Asked Questions (FAQ)

What is Proposition 65?

Proposition 65 is a California law officially known as the California Safe Drinking Water and Toxic Enforcement Act of 1986. It requires businesses to provide a "clear and reasonable" warning before exposing persons consumers, employees, and the general public to chemicals that are known to the state of California to cause cancer, birth defects, or other reproductive harm ("Listed Chemicals"). The Proposition 65 warning applies to exposures from consumer products, emissions from facilities, and workplace exposures in the State of California. Proposition 65 is a "right to know" law as opposed to a safety law, meaning Proposition 65 does not ban the use of any chemicals, but is intended to ensure the public is informed as to its exposure to Listed Chemicals.

What is/are the chemical(s) involved?

The list of the 800+Prop65 chemicals can be found at: http://www.oehha.ca.gov/prop65/prop65_list/Newlist.html . This list is periodically updated.

Are workers/employees/consumers at risk using products with a Prop65 warning?

A Prop 65 warning does not mean that the product is unsafe; however, employees and consumers should be made aware of and heed all product handling and use warnings. A Prop 65 warning does not mean that the product will actually cause cancer or other reproductive harm when used in its intended manner. Prop 65 standards for warnings are often very stringent. For example, for reproductive toxicants, the level for warnings is 1000 times lower than the lowest level at which animal studies reported no reproductive health effect.

How is a supplier selling and distributing a product containing a Prop65 Listed Chemical to provide the required warning?

A business must provide a warning with its product if it is reasonably foreseeable that a person in California will buy or receive the product. The regulations provide that the warning may appear (1) on a product, its packaging, or written materials accompanying the product, (2) at the retail outlet through shelf labeling or signs, or (3) appear through a system of signs, public advertising identifying the system, and toll-free information services provided that the warning is "clear and reasonable". The Attorney General has also advised that the warning must be provided prior to purchase for internet or mail order sales or the supplier must offer free return shipping.

Who is subject to the Proposition 65 Warning Requirement?

Proposition 65 applies to any "person in the course of doing business" with ten or more employees, including companies located outside the State of California. The term "person" is defined broadly to include any individual, trust, firm, joint stock company, corporation, company, partnership, limited liability company, and association. "In the course of doing business" means any act or omission by an employee that furthers the purpose or operation of the business, whether or not the act or omission is for profit.

Are there exceptions to the Proposition 65 Warning Requirement?

A business is not required to provide a warning if it can prove that the exposure to any Listed Chemical present in the product resulting from its normal, intended use does not pose a "significant risk" to the average user. Unfortunately, while the State of California has identified so-called "safe harbor" exposure levels, there is little regulatory guidance to determine whether or when the use of a product results in exposure below those levels and thus poses no significant risk to the average user. Because Proposition 65 places the burden on the business to prove that intended use of a product poses no significant risk, many businesses choose to provide a warning out of an abundance of caution.

Why are you telling me? I am not even in California nor do I sell anyone in California.

An out-of-state business whose products are sold and distributed within the State (including sales via the internet or by catalogue) may be liable under Proposition 65 for failing to provide adequate warnings on products that contain Listed Chemicals.

Please note that the Proposition 65 warning requirement is widely known in California and to the California legal community. As noted below, the statute includes a private enforcement mechanism that allows private citizens to bring enforcement actions against those businesses they believe have failed to meet the warning requirements. Successful private enforcers, typically law firms, are allowed to recover their attorney's fees and costs of investigation as well 25% of any penalties. In the 25+ years since Proposition 65 was adopted, these private enforcement actions have far exceeded state enforcement initiatives and resulted in thousands of settlements involving millions of dollars paid. Regardless of your location, if you don't have a Prop 65 strategy and your product can end in a sale in California, it is recommended that you may want to consult a Prop 65 knowledgeable lawyer.

Who is warning in California?

There are many commonly used consumer products and items that contain Listed Chemicals and may required warnings under Prop 65. Some of the businesses that have been sued for failure to provide a Proposition 65 notice on a product include grocery stores, drug stores, garages, hardware suppliers, car dealerships, medical facilities, retail stores, amusement parks, and many more. Some of the product categories sold in the State of California that require California Prop 65 warning include: dog toys, shoes, belts, fabric, imitation leather, foam, medications, synthetic and non-woven material, decorated glassware, decorated ceramics, beauty products, tools, garden equipment, toys and much more.

CALIFORNIA'S PROPOSITION 65 - "PROP 65"

Why are we notifying customers and warning now?

When a warning is given by a business, it means one of two things:

- (1) the business has evaluated the exposure associated with its product and concluded that intended use of the product exceeds the no significant risk level; or
- (2) the business has chosen to provide a warning based solely on its knowledge that the product or one of its components contains a Listed Chemical, without attempting to determine whether intended use results in a significant exposure or because there is no clear guidance on how to establish that exposure is insignificant. .

Recent litigation in California has shown it to be very difficult for producers to defend their product, even if the producer believes it has scientifically valid reasons to defend their position. The legal repercussions outweigh the notice implication.

Who enforces Proposition 65?

Proposition 65 gives authority to the State Attorney General and local governments (district attorneys, city attorneys and county counsel) to take enforcement action against businesses that violate the law. The statute provides for a court to impose penalties of up to \$2500 per day against a business for each day of exposure to a product sold or distributed by that business without a required warning. Proposition 65 further authorizes for injunctive relief requiring warnings be provided on future sales and distribution of products containing listed chemicals and directing market withdrawal of products that do have such warnings.

As noted above, Proposition 65 also permits a private citizen to bring the same enforcement actions against businesses to impose penalties, obtain injunctive relief and recover investigative costs and attorney's fees, provided that the private plaintiff satisfies certain procedural requirements. The vast majority of Proposition 65 litigation in California today is brought by private plaintiffs represented by a handful of law firms that specialize in this type of litigation. These private plaintiffs are commonly called "bounty hunters".

How do I protect myself from the bounty hunters?

Consider consulting a California Prop. 65 knowledgeable lawyer.

I'm uncertain of my next steps. What do I do?

Prop. 65 warnings are common throughout California in a wide range of commercial and other settings -- in hospitals, restaurants, bars, hotels, schools, grocery stores, amusement parks and on a wide variety of consumer products. People are used to them in California. If you want more information about your specific product, contact your supplier for more information regarding the chemical composition of products, product components and raw materials supplied to you. Check the Material Safety Data Sheet that accompanies any raw materials used in your own processes. If your product can end up in California, then you need a Proposition 65 strategy.

WHY ARE WE LABELING PRODUCTS?

Question: Why label products?

Answer: We identified that labeling our products was the clear and reasonable way to communicate to our customers and end users. Since our goods move around the country, this was the best way for us to show the State our full compliance with Prop 65.

Question: What does this label mean to me?

Answer: The label on our products means that we are being compliant with the State of California and have identified that some of our goods contain one or more of the chemicals that are currently on their growing list of more than 800 chemicals that could be harmful to one's health. You will now find other trusted products now bearing the same required labeling.

Question: What if our chemicals aren't on the list?

Answer: That doesn't mean they won't soon be on the list. The State of California has required that the Governor add to the list of harmful chemicals every year, at least once a year.

FOR MORE INFORMATION ON - "PROP 65"

Prop 65 Homepage

<http://oehha.ca.gov/prop65/p65faq.html>

Prop 65 in plain language

<http://oehha.ca.gov/prop65/background/p65plain.html>

List of Prop 65 chemicals

http://www.oehha.ca.gov/prop65/prop65_list/Newlist.html

ALLEGRO SOFT

Superior Strength • Tough AND Soft • Hi-Loft Backing • Easily cleaned

MANUFACTURED TO MEET
THE FOLLOWING CODES:

- Motor Vehicle Safety Standard 302
- California Tech Bulletin 117
- Federal Standard 191-A Method 5304

FINISHES and TREATMENTS

- Abrasion - heavy duty: Wyzenbeek/CFFA-1
- Heat sealable • Cold Crack -10 F
- Mildew resistant backing and face
- Light fastness: 300 hours minimum
- UV stabilized pigments



SUITABLE APPLICATIONS:
• Office
• Residential
• Automotive
• Marine • RV

SPECIFICS
• Width: 54"
• Weight: 27 ozs.
• Yards Per Roll: 30

ALL-7050 BRITTANY BLUE
ALL-7051 LIGHTNING GREY
ALL-7052 WEATHERED GREY
ALL-7053 ALABASTER
ALL-7054 GARNET
ALL-7055 COGNAC
ALL-7056 ROSEWOOD
ALL-7057 CHESAPEAKE
ALL-7058 CAPRI BLUE

ALL-7059 BLUSH WHITE
ALL-7060 COAL
ALL-7061 GLACIER
ALL-7062 SHADOW GREEN
ALL-7063 SAGE GREEN
ALL-7064 TAUPE
ALL-7065 OLD WHISKEY
ALL-7066 BRIARWOOD

Width: 54" YARD 33.30 10 YDS 30.00 30 YDS 27.50

HIGH-LOFT² BACKING SOFTSIDE THE MARINE COLLECTION

APEX™ SOFT

Superior Strength • Tough AND Soft • Hi-Loft Backing • Easily cleaned

MANUFACTURED TO MEET
THE FOLLOWING CODES:

- Motor Vehicle Safety Standard 302
- California Tech Bulletin 117
- BIFMA
- UFAC - Class I

FINISHES and TREATMENTS

- Superior abrasion Wyzenbeek/CFFA-1a 200,000 cycles
- Heat sealable • Cold Crack -10 F
- Antibacterial protection
- Mildew resistant backing and face
- UV stabilized pigments

SUITABLE APPLICATIONS
• Corporate Interiors
• Residential • Sunroom
• Casino • Hotel • Motel
• Restaurant • Healthcare
• Automotive • RV

SPECIFICS
• Width: 54"
• Weight: 29 oz
• Yards Per Roll: 30



PERMABLOK³®
ADVANCED VINYL PROTECTION

APX-2548 RAVEN
APX-2549 PEARL
APX-2550 CHERRY WOOD
APX-2551 STEEL SILVER
APX-2554 BRILLIANT WHITE
APX-2555 MIDNIGHT
APX-2556 LAME
APX-2557 PARAKEET
APX-2558 ESPRESSO
APX-2559 FROG

Width: 54" YARD 39.00 10 YDS 35.10 30 YDS 32.10

HIGH-LOFT² BACKING SOFTSIDE THE AUTOMOTIVE COLLECTION SOFTSIDE THE MARINE COLLECTION

ARIES SOFT

MARINE QUALITY EXPANDED VINYL

MANUFACTURED TO MEET
THE FOLLOWING CODES:

- Motor Vehicle Safety Standard #302
- California Tech Bulletin #117
- Abrasion - heavyduty (Wyzenbeek)
- Federal Standard 191-A Method 5304

FINISHES and TREATMENTS:

- Heat sealable
- Cold Crack -10°F (-23.3°C)
- Mildew resistant backing and face
- UV stabilized pigments
- Light fastness: 1000 hours continuous exposure CFFA-2

SUITABLE APPLICATIONS:
• Office/commercial seating
• Residential
• Marine • RV • Auto

SPECIFICS:
• Width: 54"
• Weight: 29 oz
• Yards Per Roll: 30



ARI-1601 BRILLIANT WHITE
ARI-1602 GUNMETAL
ARI-1603 MIDNIGHT
ARI-1604 SAND DOLLAR
ARI-1605 PEBBLE
ARI-1606 EBONY

Width: 54" YARD 33.30 10 YDS 30.00 30 YDS 27.50

HIGH-LOFT² BACKING SOFTSIDE THE AUTOMOTIVE COLLECTION SOFTSIDE THE MARINE COLLECTION

ATMOSPHERE

MANUFACTURED TO MEET
THE FOLLOWING CODES:

- Motor Vehicle Safety Standard 302
- California Tech Bulletin 117 Section E
- Class Ratings: ASTM D 3690 - Class A

FINISHES and TREATMENTS:

- Abrasion - heavy duty: Wyzenbeek 100,000 cycles #8 cotton duck
- Heat sealable • Cold Crack -20 F
- Mildew resistant backing & and face
- UV stabilized pigments: 500 hours minimum
- Anti-bacterial and anti-microbial: Pass*



ATMOSPHERE IS MADE WITH

Spradling's NAPA TOPCOAT FINISH

Spradling's Napa Finish is a waxy urethane topcoat which provides superior abrasion resistance. Napa topcoat possesses a soft hand intended for a comfortable, elegant leather experience but durable hand to withstand elements such as erosion caused by scratching, rubbing, and natural wear-&-tear.

SPECIFICS:
• Width: 54"
• Weight: 35 ozs.
• Thickness: 1.10mm
• Yards Per Roll: 30

SUITABLE APPLICATIONS:
• Residential • Office
• Automotive • RV
• Healthcare
• Contract Seating

ATM-1801 AZURE
ATM-1802 CHAMPAGNE
ATM-1803 ALUMINUM
ATM-1804 IRON
ATM-1805 TAUPE
ATM-1806 BRONZE
ATM-1807 COPPER
ATM-1808 MERLOT
ATM-1809 ESPRESSO
ATM-1810 MINERAL
ATM-1811 PISTACHIO
ATM-1812 EVERGREEN
ATM-1813 AUBERGINE
ATM-1814 CAFE
ATM-1815 ALDER

Width: 54" YARD 47.70 10 YDS 42.90 30 YDS 40.60

HIGH-LOFT² BACKING SOFTSIDE THE FURNITURE COLLECTION

BELUGA

MANUFACTURED TO MEET THE FOLLOWING CODES:

- Motor Vehicle Safety Standard 302
- California Tech Bulletin 117
- BIFMA
- Port Authorities of New York and New Jersey
- UFAC - Class 1
- IMO A.652(16) 8.2 & 8.3

SPECIFICS:

- Width: 54"
- Weight: 32 ozs.
- Yards Per Roll: 30

FINISHES and TREATMENTS:

- Anti-microbial and anti-bacterial protection
- Anti-stain finish
- Easily cleaned
- Abrasion - heavy duty: 100,000 cycles - Wyzenbeek/CFFA-1
- Heat sealable
- Oil resistant
- Mildew resistant backing and face
- Sulfide stain resistant / all colors
- Cold Crack -20°F (-28.9C)
- UV stabilized pigments



PERMAGUARD®
SUPERIOR STAIN RESISTANCE

- | | |
|-----------------------|---------------------|
| BEL-3301 LIGHT-YELLOW | BEL-3309 BURGUNDY |
| BEL-3302 PURE WHITE | BEL-3310 PEARL GREY |
| BEL-3303 OFF WHITE | BEL-3311 DOVE GREY |
| BEL-3304 WHITE CAP | BEL-3312 TRUE BLUE |
| BEL-3305 DUNE | BEL-3313 CELESTIAL |
| BEL-3306 PAPAYA | BEL-3314 FOREST |
| BEL-3307 OCHRE | BEL-3315 MOCCA |
| BEL-3308 CHERRY | BEL-3316 BLACKBEARD |

Width: 54"	YARD	10 YDS	30 YDS
	35.00	31.50	29.80

High-Loft² BACKING
SOFTSIDE THE MARINE COLLECTION

BUCKSKIN

MANUFACTURED TO MEET THE FOLLOWING CODES:

- California T.B. 117-2013
- FMVSS 302
- IMO FTP 2010 Code MSC.307(88) Part 8: 3.1 & 3.2
- NFPA 260- Cover Fabric - Class I
- UFAC Fabric - Class I

FINISHES and TREATMENTS:

- PVC with an Acrylic Topcoat
- Abrasion - heavy duty: Wyzenbeek/CFFA-1
- Heat sealable
- Cold Crack -10 F
- Light fastness: 300 hours minimum
- UV stabilized pigments

Superior Strength • Tough AND Soft • Hi-Loft Backing • Easily cleaned

SUITABLE APPLICATIONS

- Office
- Residential
- Automotive
- Restaurant
- Hospitality
- Commercial



CHARACTERISTICS

Formaldehyde Free
No Heavy Metals
Sulfide Stain Resistant
Superior Abrasion: 50,000 cycles | Wyzenbeek #10 Cotton Duck

UV Stabilized Pigments: Xenotest: AATCM Blue Wool | 1,000 hours

Cold Crack: -10°F

Exclusively Interiors

- | |
|-------------------------|
| BUC-7485 CHARCOAL BLACK |
| BUC-7486 CAMEL |
| BUC-7488 CRIMSON RED |

Width: 54"	YARD	15 YDS	30 YDS
	33.30	30.00	27.50

Hi-Loft flex SOFTSIDE THE AUTOMOTIVE COLLECTION

CAPRICE

MANUFACTURED TO MEET THE FOLLOWING CODES:

- California T.B. 117-2013
- FMVSS 302
- IMO FTP 2010 Code MSC.307(88) Part 8: 3.1 & 3.2
- NFPA 260- Cover Fabric - Class I
- UFAC Fabric - Class I

FINISHES and TREATMENTS:

- PVC with an Acrylic Topcoat
- Abrasion - heavy duty: Wyzenbeek/CFFA-1
- Heat sealable
- Cold Crack -10 F
- Light fastness: 300 hours minimum
- UV stabilized pigments

Superior Strength • Tough AND Soft • Hi-Loft Backing • Easily cleaned

SUITABLE APPLICATIONS

- Office
- Residential
- Automotive
- Restaurant
- Hospitality
- Commercial



CHARACTERISTICS

Formaldehyde Free
No Heavy Metals
Sulfide Stain Resistant
Superior Abrasion: 50,000 cycles | Wyzenbeek #10 Cotton Duck

UV Stabilized Pigments: Xenotest: AATCM Blue Wool | 1,000 hours

Cold Crack: -10°F

Exclusively Interiors

- | |
|----------------------------|
| CAP-7335 DARK SLATE |
| CAP-7363 LIGHT SLATE |
| CAP-7428 BLACK |
| CAP-7454 MEDIUM SLATE |
| CAP-7495 MEDIUM KHAKI |
| CAP-7842 LIGHT FROST BEIGE |

Width: 54"	YARD	15 YDS	30 YDS
	33.30	30.00	27.50

Hi-Loft flex SOFTSIDE THE AUTOMOTIVE COLLECTION

CARBON FIBER

MANUFACTURED TO MEET THE FOLLOWING CODES:

- Motor Vehicle Safety Standard 302
- California Tech Bulletin 117 Section E

FINISHES and TREATMENTS:

- Cold Crack -10 F
- Mildew Resistant Front & Back
- Superior Abrasion: 50,000 cycles - Wyzenbeek/CFFA-1

SUITABLE APPLICATIONS:

- Residential
- General seating
- General sewn products
- Auto • RV

SPECIFICS:

- Width: 54"
- Weight: 28/29 ozs./ln.yd.
- Yards Per Roll: 30



- | | |
|----------------------|---------------------|
| CAR-1100 BLACK | CAR-1106 ARLINGTON |
| CAR-1101 SILVER | CAR-1107 CHESAPEAKE |
| CAR-1102 PEARL WHITE | CAR-1109 AUTOBAHN |
| CAR-1103 TOAST | CAR-1110 FLINT |
| CAR-1104 MOCCASIN | CAR-1111 WHITE |
| CAR-1105 SANTA FE | CAR-1112 CAPE COD |

Width: 54"	YARD	10 YDS	30 YDS
	36.00	32.30	30.60

High-Loft² BACKING
SOFTSIDE THE AUTOMOTIVE COLLECTION
SOFTSIDE THE FURNITURE COLLECTION

CENERY

MANUFACTURED TO MEET THE FOLLOWING CODES:

- California T.B. 117-2013
- FMVSS 302
- IMO FTP 2010 Code MSC.307(88) Part 8: 3.1 & 3.2
- NFPA 260- Cover Fabric - Class I
- UFAC Fabric - Class I

FINISHES and TREATMENTS:

- PVC with an Acrylic Topcoat
- Abrasion - heavy duty: Wyzenbeek/CFFA-1
- Heat sealable
- Cold Crack -10 F
- Light fastness: 300 hours minimum
- UV stabilized pigments

Superior Strength • Tough AND Soft • Hi-Loft Backing • Easily cleaned

SUITABLE APPLICATIONS

- Office
- Residential
- Automotive
- Restaurant
- Hospitality
- Commercial



SPECIFICS

- Width: 54"
- Weight: 28 ozs.
- Yards Per Roll: 30

CHARACTERISTICS

- Formaldehyde Free
- No Heavy Metals
- Sulfide Stain Resistant
- Superior Abrasion: 50,000 cycles | Wyzenbeek #10 Cotton Duck

UV Stabilized Pigments: Xenotest: AATCM Blue Wool | 1,000 hours

Cold Crack: -10°F

Exclusively Interiors

CEN-7448 PEBBLE 3
CEN-7449 MEDIUM FLINT

Hi-Loft flex **SOFTSIDE**
THE AUTOMOTIVE COLLECTION

Width: 54"	YARD	15 YDS	30 YDS
	33.30	30.00	27.50

CORINTHIAN SOFT

MANUFACTURED TO MEET THE FOLLOWING CODES:

- Motor Vehicle Safety Standard 302
- California Tech Bulletin 117 Section E

FINISHES and TREATMENTS:

- Superior Abrasion: 50,000 cycles - Wyzenbeek/CFFA-1
- Cold Crack -10 F
- Mildew resistant

SUITABLE APPLICATIONS:

- Auto • RV
- Residential
- General seating

SPECIFICS:

- Width: 54"
- Weight: 28/29 ozs./ln.yd.
- Yards Per Roll: 30



COS-7291 TORCH RED

Width: 54"	YARD	10 YDS	30 YDS
	33.30	30.00	27.50

High-Loft² BACKING **SOFTSIDE**
THE AUTOMOTIVE COLLECTION

FLOTILLA II MARINE VINYL: PLAIN & CHANNEL

MANUFACTURED TO MEET THE FOLLOWING CODES:

- California Tech Bulletin 117
- Superior Abrasion (Wyzenbeek)
- Federal Standard 191-A Method 5304

FINISHES and TREATMENTS

- Heat sealable • Cold Crack -10
- Mildew resistant backing and face
- UV Stabilized pigments
- Light fastness - 300 hours minimum
- Antimicrobial protection

SUITABLE APPLICATIONS

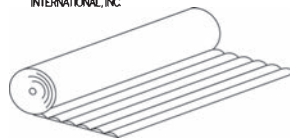

- Office
- Residential
- Marine • RV • Auto

SPECIFICS

- Width: 54"
- Weight: 29 oz.
- Yards Per Roll: 30



FLT-554 SNOW WHITE
FLT-569 MARINE WHITE

Width: 54"	YARD	10 YDS	30 YDS	CHANNEL QUILTED
	33.00	29.80	27.80	70.00

High-Loft² BACKING

GEMINI™ SOFT

MANUFACTURED TO MEET THE FOLLOWING CODES:

- Motor Vehicle Safety Standard 302
- California Tech Bulletin 117
- BIFMA
- UFAC - Class I

FINISHES and TREATMENTS

- Superior abrasion Wyzenbeek/CFFA-1a 200,000 cycles
- Heat Sealable • Cold Crack -10 F
- Antibacterial and antimicrobial protection
- Mildew Resistant Backing and Face
- UV stabilized pigments

Superior Strength • Tough AND Soft • Hi-Loft Backing • Easily cleaned

SUITABLE APPLICATIONS

- Coporate Interiors
- Residential • Sunroom
- Casino • Hotel • Motel
- Restaurant • Healthcare
- Automotive • RV



SPECIFICS

- Width: 54"
- Weight: 29 ozs.
- Yards Per Roll: 30

PERMABLOK³®
ADVANCED VINYL PROTECTION

GEM-2561 PEARL	GEM-2569 TANGERINE
GEM-2562 METROPOLITAN	GEM-2570 PARAKEET
GEM-2563 ALUMINUM	GEM-2571 ESPRESSO
GEM-2564 ALABASTER WHITE	GEM-2572 MOLTEN
GEM-2565 JUICY FIG	GEM-2573 OLD BOURBON
GEM-2566 GREEN APPLE	GEM-2574 RAVEN
GEM-2567 PASSION	
GEM-2568 ELECTRIC	

Width: 54"	YARD	15 YDS	30 YDS
	37.60	33.80	31.00

High-Loft² BACKING **SOFTSIDE** **SOFTSIDE**
THE AUTOMOTIVE COLLECTION THE MARINE COLLECTION

G GRAIN

MANUFACTURED TO MEET THE FOLLOWING CODES:

- Motor Vehicle Safety Standard 302
- California Tech Bulletin 117 Section E

FINISHES and TREATMENTS:

- Abrasion: heavy duty Wyzenbeek
- Heat sealable
- Mildew resistant • Anti-fog
- Cold Crack -10 F • QUV: 650 hours

SUITABLE APPLICATIONS:

- General seating
- General sewn products
- Marine • Auto • RV

SPECIFICS:

- Width: 54"
- Weight: 40 ozs./ln. yd.
- Yards Per Roll: 30



- GGR-7114 — MEDIUM GRAPHITE
- GGR-7119 — LIGHT GRAPHITE
- GGR-7167 — MEDIUM PRAIRIE TAN
- GGR-7221 — MEDIUM PARCHMENT
- GGR-7227 — EBONY
- GGR-7357 — MEDIUM FLINT

Width: 54" YARD 33.30 15 YDS 30.00 30 YDS 27.50

HIGH-LOFT² BACKING SOFTSIDE THE AUTOMOTIVE COLLECTION

GRAND PRIX SOFT

Superior Strength • Tough AND Soft • Hi-Loft Backing • Easily cleaned

MANUFACTURED TO MEET THE FOLLOWING CODES:

- Motor Vehicle Safety Standard 302
- California Tech Bulletin 117

FINISHES and TREATMENTS:

- Abrasion - heavy duty: Wyzenbeek/CFFA-1
- Heat sealable
- Cold Crack -10 F
- Light fastness: 300 hours minimum
- UV stabilized pigments

SUITABLE APPLICATIONS

- Office
- Residential
- Automotive

SPECIFICS

- Width: 54"
- Weight: 29 ozs.
- Yards Per Roll: 30



- GPX-9450 — SNOW WHITE
- GPX-9451 — SOFT WHITE
- GPX-9452 — CADET BLUE
- GPX-9453 — LAPIS BLUE
- GPX-9454 — ROYAL BLUE
- GPX-9455 — FLAME
- GPX-9456 — CARMINE
- GPX-9457 — BURGUNDY
- GPX-9458 — EGGPLANT
- GPX-9459 — MULBERRY
- GPX-9460 — CRANBERRY
- GPX-9461 — SILVER GREY
- GPX-9462 — LIGHT SLATE
- GPX-9464 — MED. OPAL
- GPX-9465 — MED. DARK GREY
- GPX-9466 — GRAPHITE
- GPX-9467 — BLACK
- GPX-9468 — SPICE
- GPX-9469 — BEECHWOOD
- GPX-9471 — SAND BEIGE
- GPX-9472 — BUCKSKIN
- GPX-9473 — ANTELOPE
- GPX-9474 — BRIAR BROWN
- GPX-9475 — TEAL

Width: 54" YARD 33.30 15 YDS 30.00 30 YDS 27.50

HIGH-LOFT² BACKING SOFTSIDE THE AUTOMOTIVE COLLECTION

HEIDI SOFT AUTOMOTIVE

Tough AND Soft • Hi-Loft Backing

MANUFACTURED TO MEET THE FOLLOWING CODES:

- Motor Vehicle Safety Standard 302
- California Tech Bulletin 117

FINISHES and TREATMENTS

- Abrasion - heavy duty: Wyzenbeek/CFFA-1
- Heat Sealable
- Cold Crack -10 F
- Light fastness: 300 hours minimum
- UV stabilized pigments

SPECIFICS

- Width: 54"
- Weight: 29 ozs.
- Yards Per Roll: 30



- HDI-5916 — CHARCOAL
- HDI-6106 — SMOKE
- HDI-6205 — CHESTNUT
- HDI-6247 — SCARLET
- HDI-6332 — SANDALWOOD
- HDI-6428 — CRYSTAL BLUE
- HDI-6431 — TITANIUM
- HDI-6507 — EBONY
- HDI-6588 — LIGHT MOCHA
- HDI-6688 — MEDIUM OPAL
- HDI-6812 — LAPIS BLUE

Width: 54" YARD 33.30 10 YDS 30.00 30 YDS 27.50

HIGH-LOFT² BACKING SOFTSIDE THE AUTOMOTIVE COLLECTION

HEIDI SOFT MARINE

Tough AND Soft • Hi-Loft Backing

MANUFACTURED TO MEET THE FOLLOWING CODES:

- Motor Vehicle Safety Standard 302
- California Tech Bulletin 117

FINISHES and TREATMENTS

- Abrasion - heavy duty: Wyzenbeek/CFFA-1
- Heat Sealable
- Cold Crack -10 F
- Mildew resistant backing and face
- Light fastness: 300 hours minimum
- UV stabilized pigments

SPECIFICS

- Width: 54"
- Weight: 29 ozs.
- Yards Per Roll: 30



- HDI-6850 — ASH
- HDI-6851 — PEARL
- HDI-6852 — CHAMPAGNE
- HDI-6854 — ZINC
- HDI-6855 — VANILLA
- HDI-6856 — SATIN
- HDI-6857 — PEACOCK
- HDI-6858 — MEDIUM TEAL
- HDI-6859 — ANTIQUE GREEN
- HDI-6860 — ALPINE
- HDI-6861 — CLASSIC BLUE
- HDI-6862 — CARDINAL
- HDI-9880 — BRILLIANT WHITE

Width: 54" YARD 33.30 15 YDS 30.00 30 YDS 27.50

HIGH-LOFT² BACKING SOFTSIDE THE AUTOMOTIVE COLLECTION SOFTSIDE THE MARINE COLLECTION

ISLANDER SOFT *MARINE QUALITY EXPANDED VINYL*

MANUFACTURED TO MEET THE FOLLOWING CODES:

- Motor Vehicle Safety Standard #302
- California Tech Bulletin #117
- Abrasion - heavy duty (Wyzenbeek)
- Federal Standard 191-A Method 5304

FINISHES and TREATMENTS:

- Heat sealable
- Cold Crack -10
- Mildew resistant backing and face
- UV stabilized pigments
- Light fastness - 300 hours minimum

SUITABLE APPLICATIONS:

- Office/Commercial Seating
- Residential
- Marine • RV • Auto

SPECIFICS:

- Width: 54"
- Weight: 29 oz.
- Yards Per Roll: 30



ISL-9150	CHALK	ISL-9165	REGATTA
ISL-9151	OYSTER WHITE	ISL-9166	TURQUA
ISL-9152	LIGHT GREY	ISL-9167	AQUA MARINE
ISL-9153	GUNMETAL	ISL-9168	JEWEL
ISL-9154	CHARCOAL	ISL-9169	DOESKIN
ISL-9155	EBONY	ISL-9170	MOCHA
ISL-9156	BABY BLUE	ISL-9171	TEAKWOOD
ISL-9157	BRISTOL BLUE	ISL-9172	CORAL BLUSH
ISL-9158	SILVER BLUE	ISL-9173	PEACHWOOD
ISL-9159	MIDNIGHT	ISL-9174	EVERGLADE
ISL-9160	RUBY RED	ISL-9175	GRAPE
ISL-9161	CRIMSON	ISL-9176	YELLOW
ISL-9162	BURGUNDY	ISL-9177	BRILLIANT WHITE
ISL-9163	SPINNAKER	ISL-9178	FRENCH VANILLA
ISL-9164	CADET	ISL-9179	TITAN NEUTRAL

Width: 54"	YARD	10 YDS	30 YDS
	33.30	30.00	27.50

HIGH-LOFT² BACKING **SOFTSIDE THE MARINE COLLECTION**

LONGITUDE

Superior Strength • Tough AND Soft • Hi-Loft Backing • Easily cleaned

MANUFACTURED TO MEET THE FOLLOWING CODES:

- California T.B. 117-2013
- FMVSS 302
- IMO FTP 2010 Code MSC.307(88) Part 8: 3.1 & 3.2
- NFPA 260- Cover Fabric - Class I
- UFAC Fabric - Class I

FINISHES and TREATMENTS:

- PVC with an Acrylic Topcoat
- Abrasion - heavy duty: Wyzenbeek/CFFA-1
- Heat sealable
- Cold Crack -10 F
- Light fastness: 300 hours minimum
- UV stabilized pigments

SUITABLE APPLICATIONS

- Office
- Residential
- Automotive
- Restaurant
- Hospitality
- Commercial



SPECIFICS

- Width: 54"
- Weight: 28 ozs.
- Yards Per Roll: 30

CHARACTERISTICS

- Formaldehyde Free
- No Heavy Metals
- Sulfide Stain Resistant
- Superior Abrasion: 50,000 cycles | Wyzenbeek #10 Cotton Duck

UV Stabilized Pigments: Xenotest: AATCM Blue Wool | 1,000 hours

Cold Crack: -10°F

Exclusively Interiors

LON-7692 EBONY
LON-7693 LIGHT CASHMERE
LON-7694 LIGHT TITANIUM
LON-7695 DARK TITANIUM

Width: 54"	YARD	15 YDS	30 YDS
	33.30	30.00	27.50

Hi-Loft flex **SOFTSIDE THE AUTOMOTIVE COLLECTION**

MADRID SOFT

MANUFACTURED TO MEET THE FOLLOWING CODES:

- Motor Vehicle Safety Standard 302
- California Tech Bulletin 117 Section E

FINISHES and TREATMENTS:

- Abrasion: heavy duty Wyzenbeek
- Cold Crack -10 F • QUV: 650 hours
- Heat sealable
- Anti-fog

SUITABLE APPLICATIONS:

- General seating
- General sewn products
- Marine • Auto • RV

SPECIFICS:

- Width: 54"
- Weight: 30 ozs./ In. yd.
- Yards Per Roll: 30



MAS-9830	BLACK
MAS-9831	OFF-WHITE
MAS-9832	DARK GREEN
MAS-9833	TURQUOISE
MAS-9834	GOLD

Width: 54"	YARD	10 YDS	30 YDS
	33.30	30.00	27.50

HIGH-LOFT² BACKING **SOFTSIDE THE AUTOMOTIVE COLLECTION**

MARLIN

MANUFACTURED TO MEET THE FOLLOWING CODES:

- Motor Vehicle Safety Standard 302
- California Tech Bulletin 117 Section E

FINISHES and TREATMENTS:

- Abrasion: 100,000 Cycles Wyzenbeek
- Cold Crack -20 F • QUV: 650 hours
- Mildew Resistant Front & Back
- Anti-stain
- Anti-static

SUITABLE APPLICATIONS:

- Contract Interiors
- Office
- Restaurant
- Hotel/Motel
- Residential
- Sunrooms
- Patios- Hospitals
- Nursing Homes
- Auto & RV
- Marine



SPECIFICS:

- Width: 54"
- Weight: 30 ozs./ In. yd.
- Yards Per Roll: 30

PERMAGUARD®
SUPERIOR STAIN RESISTANCE

MRL-3201	IVORY	MRL-3210	ARCTIC SKY
MRL-3202	PURE WHITE	MRL-3211	AUSTER
MRL-3203	BRILLIANT WHITE	MRL-3215	APRICOT
MRL-3204	OFF WHITE	MRL-3216	PAPAYA
MRL-3206	CREAM	MRL-3217	CHERRY
MRL-3207	LIGHT-YELLOW	MRL-3218	OCHRE
MRL-3208	PARCHMENT	MRL-3220	MOCHA
MRL-3209	DUNE	MRL-3222	MEDITERRANEAN

Width: 54"	YARD	10 YDS	30 YDS
	34.30	30.90	29.20

HIGH-LOFT² BACKING **SOFTSIDE THE MARINE COLLECTION**

MILLED PEBBLE

MANUFACTURED TO MEET THE FOLLOWING CODES:

- Motor Vehicle Safety Standard 302
- California Tech Bulletin 117 Section E

FINISHES and TREATMENTS:

- Abrasion - heavy duty: Wyzenbeek/CFFA-1
- Heat embossable only
- Cold Crack -10 F • QUV: 650 hours
- Anti-fog: SAE J1756

SUITABLE APPLICATIONS:

- Residential
- General seating
- General sewn products
- Marine • Auto • RV

SPECIFICS:

- Width: 54"
- Weight: 29 ozs./ In. yd.
- Yards Per Roll: 30

- MIL-7360—LIGHT PARCHMENT
- MIL-7396—DARK FLINT
- MIL-7397—EBONY
- MIL-7399—MEDIUM GRAPHITE
- MIL-7400—MIDNIGHT-BLACK
- MIL-7443 PEBBLE III
- MIL-7444—MEDIUM FLINT
- MIL-7476—CAMEL
- MIL-7514—MEDIUM-DARK-STONE
- MIL-7515—SAND
- MIL-7518—LIGHT-CAMEL
- MIL-7520—MEDIUM-LIGHT-STONE



Width: 54"	YARD 33.30	10 YDS 30.00	30 YDS 27.50
-------------------	----------------------	------------------------	------------------------

HIGH-LOFT²
BACKING

SOFTSIDE
THE AUTOMOTIVE
COLLECTION

MONTANA SOFT

MANUFACTURED TO MEET THE FOLLOWING CODES:

- Motor Vehicle Safety Standard 302
- California Tech Bulletin 117

FINISHES and TREATMENTS:

- Abrasion - heavy duty: Wyzenbeek/CFFA-1
- Heat sealable
- Cold Crack -10 F
- Light fastness: 300 hours minimum
- UV stabilized pigments

SUITABLE APPLICATIONS:

- Office
- Residential
- Automotive

SPECIFICS:

- Width: 54"
- Weight: 29 ozs.
- Yards Per Roll: 30

Practical and durable!



- MOS-6046—OXFORD-WHITE
- MOS-9375 CHARCOAL
- MOS-9377 DESERT TAN
- MOS-9378 BLACK
- MOS-9379—DARK-BLUE
- MOS-9380—OXFORD-GREY
- MOS-9381 CANYON RED
- MOS-9382—REGATTA-BLUE
- MOS-9383—SAND-BEIGE
- MOS-9384 SMOKE
- MOS-9385—CHESTNUT
- MOS-9376—CADET-BLUE
- MOS-9386 SCARLET
- MOS-9387 M. TITANIUM
- MOS-9388—M. CRYSTAL-BLUE
- MOS-9389—L. TITANIUM



Width: 54"	YARD 33.30	10 YDS 30.00	30 YDS 27.50
-------------------	----------------------	------------------------	------------------------

HIGH-LOFT²
BACKING

SOFTSIDE
THE AUTOMOTIVE
COLLECTION

MONTICELLO SOFT

MANUFACTURED TO MEET THE FOLLOWING CODES:

- Motor Vehicle Safety Standard 302
- California Tech Bulletin 117 Section E

FINISHES and TREATMENTS:

- Abrasion: 6000 stainless steel screen wire
- Heat Sealable: Di-electrically and RF Sealable
- Cold Crack -10 F • QUV: 650 hours
- Anti-fog: SAE J1756

SUITABLE APPLICATIONS:

- Residential
- General seating
- General sewn products
- Marine • Auto • RV

SPECIFICS:

- Width: 54"
- Weight: 29ozs./In. yd.
- Yards Per Roll: 30

- MOT-6890 MEDIUM GREY
- MOT-6891 MEDIUM BEIGE
- MOT-6892 GRAPHITE
- MOT-6973 NAVY
- MOT-6974 RUBY RED
- MOT-7043 MEDIUM NEUTRAL
- MOT-7179 MEDIUM DARK PEWTER
- MOT-7323 SHALE
- MOT-7346 VERY DARK PEWTER
- MOT-9800 MEDIUM GRAPHITE
- MOT-9801 MEDIUM PRAIRIE TAN
- MOT-9802 SAND STONE
- MOT-9803 MEDIUM CAMEL
- MOT-9805 BRITISH WHITE
- MOT-9806 LIGHT GREY
- MOT-9808 TORCHFIRE RED
- MOT-9809—SADDLE
- MOT-9810 BLACK



Width: 54"	YARD 33.30	10 YDS 30.00	30 YDS 27.50
-------------------	----------------------	------------------------	------------------------

HIGH-LOFT²
BACKING

SOFTSIDE
THE AUTOMOTIVE
COLLECTION

NAVIGATOR SOFT

Superior Strength • Tough AND Soft • Hi-Loft Backing • Easily cleaned

MANUFACTURED TO MEET THE FOLLOWING CODES:

- Motor Vehicle Safety Standard 302
- California Tech Bulletin 117
- Federal Standard 191-A Method 5304

FINISHES and TREATMENTS:

- Abrasion - heavy duty: Wyzenbeek/CFFA-1
- Heat sealable • Cold Crack -10 F
- Mildew resistant backing and face
- Light fastness: 300 hours minimum
- UV stabilized pigments

SUITABLE APPLICATIONS:

- Office
- Residential
- Automotive
- Marine • RV

SPECIFICS:

- Width: 54"
- Weight: 29 ozs.
- Yards Per Roll: 30

- NAV-9890 SNOW
- NAV-9891 MOONBEAM
- NAV-9892 GLACIER
- NAV-9893 WHITECAP
- NAV-9894 PARCHMENT
- NAV-9895 SAND DOLLAR
- NAV-9896 STONE
- NAV-9897 PEBBLE
- NAV-9898 DOLPHIN
- NAV-9899 CAPRI
- NAV-9900 MERMAID
- NAV-9901 BLUE RIBBON
- NAV-9902 CELESTIAL
- NAV-9903 VALENTINE
- NAV-9904 CRIMSON
- NAV-9905 BLACKBEARD
- NAV-9906 SUNDANCE
- NAV-9907 PURPLE PASSION



Width: 54"	YARD 33.30	10 YDS 30.00	30 YDS 27.50
-------------------	----------------------	------------------------	------------------------

HIGH-LOFT²
BACKING

SOFTSIDE
THE MARINE
COLLECTION

NUANCE

MANUFACTURED TO MEET THE FOLLOWING CODES:

- BIFMA Class A
- California Tech Bulletin #117
- Boston Fire Code - Test BFD IX-1
- Motor Vehicle Safety Standard 302

FINISHES & TREATMENTS:

- Abrasion - heavy duty: 100,000 cycles - Wyzenbeek/CFFA Federal Standard 191 - A Method 5304
- Cold Crack -10 degrees F
- Thickness 1.2mm
- UV stabilized pigments
- Polyester backing
- Oil and Sulfide Resistant
- Mildew resistant backing and face

SPECIFICS:

- Width: 54" (137cm)
- Weight: 26 oz.
- Yards Per Roll: 30
- Content: PVC

Clean with mild soap and water.
Do not use alcohol based cleaners

NUANCE IS MADE WITH

Spradling's NAPA TOPCOAT FINISH

Spradling's Napa Finish is a waxy urethane topcoat which provides superior abrasion resistance.

Napa topcoat possesses a soft hand intended for a comfortable, elegant leather experience but durable hand to withstand elements such as erosion caused by scratching, rubbing, and natural wear-&-tear.

SUITABLE APPLICATIONS:

- Automotive
- RV
- Office Seating
- Residential
- Seating,
- Hospitality
- Home Office
- Lounge Seating
- Healthcare
- Spa Massage Table



- NUA-2473 COGNAC
- NUA-2450 SNOW WHITE
- NUA-2451 WHITE
- NUA-2452 SAND
- NUA-2453 SANDSTONE
- NUA-2454 FAWN
- NUA-2457 EBONY
- NUA-2458 DARK GRAPHITE
- NUA-2459 NAVY
- NUA-2460 MEDIUM GREY
- NUA-2461 MEDIUM DARK PEWTER
- NUA-2462 VERY DARK PEWTER
- NUA-2463 MEDIUM NEUTRAL
- NUA-2465 SHALE
- NUA-2466 KHAKI
- NUA-2467 TURMERIC
- NUA-2468 GROUSE
- NUA-2469 COCONUT HUSK
- NUA-2470 COFFEE BEAN
- NUA-2471 ECLIPSE
- NUA-2472 CHAMOIS
- NUA-2474 FIREFLY
- NUA-2475 MERLOT
- NUA-2476 SPRITE
- NUA-2477 OCEAN

Width: 54" YARD 38.50 10 YDS 34.70 30 YDS 31.80

HIGH-LOFT²
BACKING

SOFTSIDE
THE AUTOMOTIVE
COLLECTION

SOFTSIDE
THE FURNITURE
COLLECTION

ORION SOFT

Superior Strength • Tough AND Soft • Hi-Loft Backing • Easily cleaned

MANUFACTURED TO MEET THE FOLLOWING CODES:

- Motor Vehicle Safety Standard #302
- California Tech Bulletin #117
- Federal Standard 191-A Method 5304

FINISHES and TREATMENTS:

- Abrasion - heavy duty (Wyzenbeek)
- Heat sealable • Cold Crack -10°F (-23.3°C)
- Mildew resistant backing and face
- UV stabilized pigments
- Light fastness: 1000 hours continuous exposure CFFA-2

SUITABLE APPLICATIONS:

- Office/Commercial seating
- Residential
- Marine • RV • Auto

SPECIFICS:

- Width: 54"
- Weight: 29 oz.
- Yards Per Roll: 30



- ORI-1607 BRILLIANT WHITE
- ORI-1608 GUNMETAL
- ORI-1609 MIDNIGHT
- ORI-1610 SAND DOLLAR
- ORI-1611 PEBBLE
- ORI-1612 EBONY

Width: 54" YARD 33.30 10 YDS 30.00 30 YDS 27.50

HIGH-LOFT²
BACKING

SOFTSIDE
THE AUTOMOTIVE
COLLECTION

SOFTSIDE
THE MARINE
COLLECTION

OXEN SOFT

MANUFACTURED TO MEET THE FOLLOWING CODES:

- Motor Vehicle Safety Standard 302
- California Tech Bulletin 117 Section E

FINISHES and TREATMENTS:

- Abrasion - heavy duty: Wyzenbeek/CFFA-1
- Heat sealable: di-electrically and RF sealable
- Cold Crack -10 F • QUV: 40 hours
- Mildew resistant: ASTM - G21
- Anti-fog: SAE J1756

SUITABLE APPLICATIONS:

- Residential
- General seating
- General sewn products
- Marine • Auto • RV

SPECIFICS:

- Width: 54"
- Weight: 28 ozs./ In. yd.
- Yards Per Roll: 30



- OXS-9840 BLACK
- OXS-9841 SMOKE GREY
- OXS-9842 BUCKSKIN
- OXS-9843 MAROON
- OXS-9845 BONE
- OXS-9846 DARK BLUE

Width: 54" YARD 33.30 10 YDS 30.00 50 YDS 27.50

HIGH-LOFT²
BACKING

SOFTSIDE
THE AUTOMOTIVE
COLLECTION

PATRIOT PLUS II™

MANUFACTURED TO MEET THE FOLLOWING CODES:

- BIFMA • Boston Fire Code Test BFD IX 1
- California Tech Bulletin 117
- Federal Aviation Specification FAR 25.853 (a) & Appendix F Part 1 (a) (1) (ii)
- Federal Specification A-A-2950A
- Motor Vehicle Safety Standard 302
- NFPA 701(Small Scale)
- Port Authorities of New York & New Jersey
- UFAC Class 1 • Mass. 527 cmr 21.00
- NFPA 260-Class1 • IMO A.652 (16) 8.2 & 8.3
- Patriot Plus, when tested with suitable component materials, may comply with California Technical Bulletin #133 and Boston Fire Code - Test BFD IX-10.

FINISHES and TREATMENTS:

- Permablok³ Advanced vinyl protection
- Anti-microbial and anti-bacterial protection
- Anti-stain finish • Easily cleaned
- Superior abrasion resistance 400,000 Cycles Wyzenbeek/CFFA 1 (Federal Standard 191-A Method 5304)
- Antistatic slip finish
- Antistatic (ASTM D-257)
- Cold Crack -20°F (-28.9C)
- Heat Sealable • Oil resistant
- Mildew resistant backing and face
- Sulfide stain resistant / all colors
- UV stabilized pigments
- 100% Polyester knit backing

SUITABLE APPLICATIONS:

- Contract Interiors
- Office
- Restaurant
- Hotel/Motel
- Nursing Home • Hospital
- Sunroom • Patio
- Marine • RV • Auto
- Residential

SPECIFICS:

- Width: 54"
- Weight: 34 ozs.
- Yard Per Roll: 30



The Contract Collection
34oz Contract Vinyl

PERMABLOK³®
ADVANCED VINYL PROTECTION

PAT-8501 ADOBE WHITE	PAT-8563—CHINA-GREEN	PAT-8607—HARVEST
PAT-8503—PARCHMENT	PAT-8564 GROTTO	PAT-8608—OCHRE
PAT-8504 SAND	PAT-8565—TEA ROSE	PAT-8609—CORAL
PAT-8506 PUTTY	PAT-8566—VINTAGE BONE	PAT-8610 SABLE
PAT-8509—LEMON-PEEL	PAT-8567 DOVE	PAT-8611 TERRA COTTA
PAT-8516 CHESTNUT	PAT-8569 BURGUNDY	PAT-8612—CHERRY
PAT-8517 MOCHA	PAT-8571 FOREST	PAT-8613 ORANGE KIST
PAT-8528 AMERICAN BEAUTY	PAT-8572 BLUERIDGE	PAT-8614 SALSA
PAT-8529 PAPIKA	PAT-8574—BUTTERNUT	PAT-8615 BERRY
PAT-8532 BORDEAUX	PAT-8575—GRAPHITE	PAT-8616—EGGPLANT
PAT-8533 PORT	PAT-8576 DEEP PHOENICIAN	PAT-8617—AMETHYST
PAT-8536—BLUSH	PAT-8577 PURPLE GREY	PAT-8618 AUBERGINE
PAT-8537—ROSE	PAT-8578—FIESTA-RED	PAT-8619—PLUM
PAT-8539 GUNMETAL	PAT-8579 RUBY	PAT-8620 PEACOCK
PAT-8540 BLACK	PAT-8581 DARK AQUA	PAT-8621—BLUEBERRY
PAT-8541 SPACE BLUE	PAT-8582 IMPERIAL BLUE	PAT-8622—GRAY MOSS
PAT-8542 ROYAL	PAT-8584 TAUPE	PAT-8623 SAGE
PAT-8544 SAPPHIRE	PAT-8601—BUFF	PAT-8624 GRANNY SMITH
PAT-8546 COLONIAL BLUE	PAT-8602—OATMEAL	PAT-8625 CYPRESS
PAT-8547 MIDNIGHT BLUE	PAT-8603 LARK	PAT-8626 EUCALYPTUS
PAT-8553 YEW GREEN	PAT-8604 CONCRETE	PAT-8627—PINE-FOREST
PAT-8560 AQUA GREY	PAT-8605 CHARCOAL	PAT-8628 SEA
PAT-8561 MULBERRY	PAT-8606—SAFFRON	PAT-8629—LODEN

Width: 54"	YARD 43.40	10 YDS 39.50	30 YDS 37.10
-------------------	----------------------	------------------------	------------------------

HIGH-LOFT²
BACKING

SPRADLING'S PERMABLOK³®

PERMABLOK³®
ADVANCED VINYL PROTECTION

PERMABLOK³ from Spradling is a proven vinyl protective coating that is engineered to create a tough, effective barrier against the three biggest problems encountered in today's commercial environment; germs, abrasions, and stains.

No. 1 - It offers unsurpassed microbial protection against both gram positive and negative bacteria plus fungus, mold and mildew.

No. 2 - it provides outstanding stain protection and easy cleanability.

No. 3 - It incorporates superior abrasion protection against scuffs, scrapes and everyday wear.

(To obtain ideal performance and long lasting good looks, proper care is important.)

Spradling provides you with a step by step cleaning guide for:

- | | | | |
|-----------------|----------------------|------------------|----------------------|
| • Mascara | • Coffee | • Tar | • Blood |
| • Red Lipstick | • Crayon | • Grease | • Feces |
| • Eye Shadow | • Chocolate | • Asphalt | • Urine |
| • Suntan Lotion | • Black felt tip pen | • Oil base paint | • Other tough stains |



SPRADLING'S CARE & CLEANING GUIDE

STAINING AGENT	CLEANING PROCEDURE
Eye Shadow	Step 1
Mascara	Step 1
Grease	Step 1
Crayon	Step 1
Black Felt Tip Pen	Step 1
Chocolate	Step 1
Suntan Lotion	Step 1
Red Lipstick	Step 2
Blood, Urine, Feces	Step 3
Oil Base Paint	Step 3
Tar, Asphalt	Step 3
Other Tough Stains	Step 4 or 5

- Step 1:** Remove excess spill with damp cloth. Clean with 1:1 mix of Ivory[®] Liquid or similar, and water. Rinse with clean water and dry.
- Step 2:** Use straight application of concentrated cleaners such as Formula[®] or Fantastik[®] spray cleaner. Then wipe with clean cloth.
- Step 3:** Use a 1:1 mix of ammonia and water or a 1:4 mix of bleach and water. Rinse with clean water and dry.
- Step 4:** Use straight application of naphtha (lighter fluid). Rinse thoroughly with clean water and pat surface dry.
- Step 5:** Use 1:1 mix of isopropyl alcohol and water. If stain persists, use straight alcohol. Rinse thoroughly with clean water and pat surface dry. If stains remain, use a 1:1 mix of acetone and water. Rinse with clean water and pat surface dry.
- Note:** For cleaning that requires steps 4 or 5 - use a soft cotton cloth saturated with the cleaning material, rub the stain in circles 10 times. Pat dry with another soft cotton cloth and check results.

PLEASE NOTE:

The lab at the factory contends that Armor All is probably the worst cleaning agent to apply to vinyl. The chemical reaction between Armor All and vinyl-coated fabrics will cause plasticizer migration. This can lead to claims that we will not be able to support and voids the protective capabilities of Permablok[®]

PEGASUS SOFT

Superior Strength • Tough AND Soft • Hi-Loft Backing • Easily cleaned

MANUFACTURED TO MEET THE FOLLOWING CODES:

- Motor Vehicle Safety Standard #302
- California Tech Bulletin #117
- Federal Standard 191-A Method 5304

FINISHES and TREATMENTS:

- Abrasion - heavy duty (Wyzenbeek)
- Heat sealable
- Cold Crack -10°F (-23.3°C)
- Mildew resistant backing and face
- UV stabilized pigments
- Light fastness: 1000 hours continuous exposure CFFA-2

SUITABLE APPLICATIONS:

- Office/Commercial seating
- Residential
- Marine • RV • Auto

SPECIFICS:

- Width: 54"
- Weight: 28 oz.
- Yards Per Roll: 30



- PEG-1613 BRILLIANT WHITE
- PEG-1614 GUN METAL
- PEG-1615 MIDNIGHT
- PEG-1616 SAND DOLLAR
- PEG-1617 PEBBLE
- PEG-1618 EBONY

Width: 54"	YARD 33.30	10 YDS 30.00	30 YDS 27.50
-------------------	----------------------	------------------------	------------------------

HIGH-LOFT²
BACKING

SOFTSIDE
THE AUTOMOTIVE
COLLECTION

SOFTSIDE
THE MARINE
COLLECTION

POLARIS SOFT

Superior Strength • Tough AND Soft • Hi-Loft Backing • Easily cleaned

MANUFACTURED TO MEET THE FOLLOWING CODES:

- Motor Vehicle Safety Standard #302
- California Tech Bulletin #117
- Federal Standard 191-A Method 5304

FINISHES and TREATMENTS:

- Abrasion - heavy duty (Wyzenbeek)
- Heat sealable
- Cold Crack -10°F (-23.3°C)
- Mildew resistant backing and face
- UV stabilized pigments
- Light fastness: 1000 hours continuous exposure CFFA-2

SUITABLE APPLICATIONS:

- Office/Commercial seating
- Residential
- Marine • RV • Auto

SPECIFICS:

- Width: 54"
- Weight: 29 oz.
- Yards Per Roll: 30



- POL-1619 BRILLIANT WHITE
- POL-1620 GUNMETAL
- POL-1621 MIDNIGHT
- POL-1622 SAND DOLLAR
- POL-1623 PEBBLE
- POL-1624 EBONY

Width: 54"	YARD 33.30	10 YDS 30.00	30 YDS 27.50
-------------------	----------------------	------------------------	------------------------

HIGH-LOFT²
BACKING

SOFTSIDE
THE AUTOMOTIVE
COLLECTION

SOFTSIDE
THE MARINE
COLLECTION

PRELUDE CONTRACT VINYL

PERMABLOK³[®]
ADVANCED VINYL PROTECTION

MANUFACTURED TO MEET THE FOLLOWING CODES:

- Motor Vehicle Safety Standard 302
- California Tech Bulletin 117
- BIFMA
- Federal Aviation Specification FAR 25.853 (a) & Appendix F Part I(a)(1)(ii)
- Federal Specification A-A-2950-A
- Port Authorities of New York and New Jersey
- UFAC - Class 1
- IMO A.652(16) 8.2 & 8.3

SPECIFICS:

- Width: 54"
- Weight: 32 ozs.
- Yards Per Roll: 30

FINISHES and TREATMENTS:

- Anti-microbial and anti-bacterial protection
- Anti-stain finish
- Easily cleaned
- Abrasion - heavy duty: 200,000 cycles - Wyzenbeek/CFFA-1
- Anti-static slip finish
- Heat sealable
- Oil resistant
- Mildew resistant backing and face
- Sulfide stain resistant / all colors
- Cold Crack -20°F (-28.9°C)
- UV stabilized pigments



- PRE-1001 TAUPE
- PRE-1002 SPICE
- PRE-1003 SAGE BRUSH
- PRE-1005 IVORY
- PRE-1007 LILAC
- PRE-1009 MAUVE
- PRE-1010 MINT
- PRE-1011 JADESTONE
- PRE-1012 AZURE
- PRE-1013 SALMON
- PRE-1015 CRANBERRY

- PRE-1016 COBALT
- PRE-1017 TEAL
- PRE-1018 BLUE HERON
- PRE-1019 MAHOGANY
- PRE-1020 REDWOOD
- PRE-1021 COFFEE
- PRE-1023 LIGHT SLATE
- PRE-1024 MICA
- PRE-1025 COAL
- PRE-1029 PARCHMENT
- PRE-1031 DARK CLARET
- PRE-1004 WINTER WHITE
- PRE-1028 RUBY-RED

Width: 54"	YARD 47.80	10 YDS 43.10	30 YDS 40.70
-------------------	----------------------	------------------------	------------------------

HIGH-LOFT²
BACKING

SOFTSIDE
COLLECTION

REFLEX

MANUFACTURED TO MEET THE FOLLOWING CODES:

- Motor Vehicle Safety Standard 302
- California Tech Bulletin 117
- BIFMA
- Federal Specification A-A-2950-A
- Port Authorities of New York and New Jersey
- UFAC - Class 1
- IMO A.652(16) 8.2 & 8.3

SPECIFICS:

- Width: 54"
- Weight: 32 ozs.
- Yards Per Roll: 30

FINISHES and TREATMENTS:

- Anti-microbial and anti-bacterial protection
- Anti-stain finish
- Easily cleaned
- Abrasion - heavy duty: 100,000 cycles - Wyzenbeek/CFFA-1
- Anti-static slip finish
- Heat sealable
- Oil resistant
- Mildew resistant backing and face
- Sulfide stain resistant / all colors
- Cold Crack -20°F (-28.9C)
- UV stabilized pigments



PERMABLOK³
ADVANCED VINYL PROTECTION

REF-7801 SILVER
REF-7802 POOL
REF-7803 AEGEAN
REF-7804 SAPPHIRE
REF-7805 SNOW
REF-7806 TAUPE
REF-7807 BARK
REF-7808 MOCHA
REF-7809 COPPER
REF-7810 TANGELO

Ag SILVERGUARD[®]
SILVER ION TECHNOLOGY

REF-7811 FLAME
REF-7812 RAISIN
REF-7813 WHEAT
REF-7814 MOSS
REF-7815 GRANNY SMITH
REF-7816 LAWN
REF-7817 ICE
REF-7818 CHARCOAL
REF-7819 BLACK

Width: 54" **YARD 54.60** **10 YDS 49.00** **30 YDS 45.00**

HIGH-LOFT² BACKING **SOFTSIDE** THE FURNITURE COLLECTION

REFLEX MQ

MARINE QUALITY

MANUFACTURED TO MEET THE FOLLOWING CODES:

- Motor Vehicle Safety Standard 302
- California Tech Bulletin 117
- IMO FTP 2010 Code MSC.307(88) Part 8: 3.1 & 3.2
- NFPA 260- Cover Fabric - Class I
- UFAC Fabric - Class I

SPECIFICS:

- Width: 54"
- Weight: 30 ozs.
- Yards Per Roll: 30

FINISHES and TREATMENTS:

- Anti-microbial and anti-bacterial protection
- Pink Stain Resistant
- Abrasion - heavy duty: 50,000 cycles - Wyzenbeek/CFFA-1
- Heat sealable
- Oil resistant
- Mildew resistant backing and face
- Sulfide stain resistant / all colors
- Cold Crack -10°F (-28.9C)
- UV stabilized pigments



PERMABLOK³
ADVANCED VINYL PROTECTION

RMQ-7851 PEARL
RMQ-7852 MINERAL
RMQ-7853 VOLTRON
RMQ-7854 PRO TOUR RED
RMQ-7855 BLADE
RMQ-7856 HAIL

Width: 54" **YARD 45.30** **10 YDS 40.70** **30 YDS 37.30**

HIGH-LOFT² BACKING **SOFTSIDE** THE MARINE COLLECTION

RENAISSANCE

MANUFACTURED TO MEET THE FOLLOWING CODES:

- BIFMA
- California Tech Bulletin #117
- Federal Aviation Specification FAR 25.853(a) and Appendix F Part I(a)(1)(ii)
- Boston Fire Code - Test BFD IX-1
- Port Authorities of New York and New Jersey
- Motor Vehicle Safety Standard 302
- UFAC - Class 1

SPECIFICS:

- Width: 54" (137cm)
- Weight: 34 oz. (770gm/m²)
- Yards Per Roll: 30 (27.43m)

FINISHES & TREATMENTS:

- Antimicrobial and antibacterial protection
- Antistain finish • Easily cleaned
- Mildew resistant backing and face
- Superior abrasion resistance 200,000 cycles - Wyzenbeek/CFFA-1 Federal Standard 191 - A Method 5304
- Cold Crack -20 degrees F (-28.9C)
- Heat sealable
- UV stabilized pigments
- Oil resistant backing and face
- Sulfide stain resistant / all colors



PERMABLOK³
ADVANCED VINYL PROTECTION

REN-9202 PERIWINKLE
REN-9204 SPICE
REN-9206 CARBON
REN-9208 WINEBERRY
REN-9212 BLUE JADE
REN-9213 PEACOCK
REN-9214 STEEL BLUE
REN-9215 CURRANT

Width: 54" **YARD 52.60** **10 YDS 46.30** **30 YDS 43.40**

HIGH-LOFT² BACKING

RUFFINO SOFT

MANUFACTURED TO MEET THE FOLLOWING CODES:

- Motor Vehicle Safety Standard 302
- California Tech Bulletin 117 Section E

FINISHES and TREATMENTS:

- Superior Abrasion (Wyzenbeek)
- Heat sealable: di-electrically and RF sealable
- Cold Crack -10 F • QUV: 650 hours
- Anti-static

SUITABLE APPLICATIONS:

- Residential
- General seating
- General sewn products
- Marine • Auto • RV

SPECIFICS:

- Width: 54"
- Weight: 28/29 ozs./ln.yd.
- Yards Per Roll: 30



RUS-9850 BLACK

Width: 54" **YARD 33.30** **10 YDS 30.00** **30 YDS 27.50**

HIGH-LOFT² BACKING **SOFTSIDE** THE AUTOMOTIVE COLLECTION

SEA BREEZE MARINE VINYL

MANUFACTURED TO MEET THE FOLLOWING CODES:

- Motor Vehicle Safety Standard #302
- California Tech Bulletin #117
- Federal Standard 191-A Method 530404

FINISHES and TREATMENTS:

- Abrasion - heavy duty (Wyzenbeek)
- UV stabilized pigments
- Antimicrobial protection
- Mildew resistant backing and face
- Heat sealable • Cold Crack -10°F (-23.3°C)
- Light fastness: 300 hours minimum

SUITABLE APPLICATIONS:

- Office Seating
- Commercial Seating
- Residential
- Marine • RV • Auto

SPECIFICS:

- Width: 54"
- Weight: 29 oz.
- Yards Per Roll: 30



MARINE QUALITY EXPANDED VINYL

- SEA-850 SEAFOAM
- SEA-851 SEASHELL
- SEA-852 FOG
- SEA-853 MIST

- SEA-854 TWILIGHT
- SEA-855 BIMINI BLUE
- SEA-856 BERMUDA BLUE
- SEA-857 BLUE MARLIN
- SEA-858 SUMMER SAND
- SEA-859 LIGHT COPPER
- SEA-860 GINSENG BROWN
- SEA-861 BAYBERRY
- SEA-862 CORAL

Width: 54"	YARD	10 YDS	30 YDS
	33.30	30.00	27.50

HIGH-LOFT² BACKING SOFTSIDE THE MARINE COLLECTION

SEAQUEST COLLECTION

Stocked in our Michigan Warehouse!
Matches the Marine Hidem Welt (page 218)

MANUFACTURED TO MEET THE FOLLOWING CODES:

- MVSS 302
- CAL 117, Sec. E
- UFAC Class 1
- BIFMA Section 3 & 4
- NFPA 260
- IMO A.652 (16) 8.2
- IMO A.652 (16) 8.3



FINISHES and TREATMENTS:

- Weatherproof
- Mildew Resistant ASTM G21-96(2002)
- Resistant to Seawater
- UV Resistant to 1000 Hours ASTM G26-96 Method C / CFFA-1A
- Cold Crack -10°F (-23.3°C)
- Heavy Duty Performance 175,000 Double Rubs Wyzenbeek
- Backing: 100% Polyester Knit

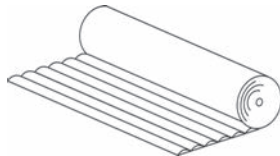

SUITABLE APPLICATIONS:

- Office/Commercial seating
- Residential
- Marine • RV • Auto

SPECIFICS:

- Width: 54"
- Weight: 32 oz.
- Yards Per Roll: PLEATED: 15
- Yards Per Roll: PLAIN: 40

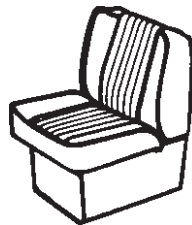

1 1/2" CHANNELS

- PSP-001 AMERICAN BEAUTY
- PSP-002 ANCHOR
- PSP-003 BUFF
- PSP-004 CHALK
- PSP-005 COVE
- PSP-006 DUNE
- PSP-007 EBONY
- PSP-008 EMERALD
- PSP-009 FOREST
- PSP-010 HAMPTON
- PSP-011 HAVASU
- PSP-012 LEMON PEEL
- PSP-013 LIGHTHOUSE RED
- PSP-014 LOTION
- PSP-015 MARBLE
- PSP-016 MIDNIGHT
- PSP-017 MIST
- PSP-018 NAVEL
- PSP-019 NAVY
- PSP-020 OYSTER
- PSP-021 PEARL OYSTER
- PSP-022 PELICAN
- PSP-023 ROYAL
- PSP-024 RUBY
- PSP-025 SEA WHITE
- PSP-026 SMOKE
- PSP-027 TEAL
- PSP-029 TOO WHITE
- PSP-030 WHITE ICE

NON-PLEATED (PLAIN)

- PSQ-001 AMERICAN BEAUTY
- PSQ-002 ANCHOR
- PSQ-003 BUFF
- PSQ-004 CHALK
- PSQ-005 COVE
- PSQ-006 DUNE
- PSQ-007 EBONY
- PSQ-008 EMERALD
- PSQ-009 FOREST
- PSQ-010 HAMPTON
- PSQ-011 HAVASU
- PSQ-012 LEMON PEEL
- PSQ-013 LIGHTHOUSE RED
- PSQ-014 LOTION
- PSQ-015 MARBLE
- PSQ-016 MIDNIGHT
- PSQ-017 MIST
- PSQ-018 NAVEL
- PSQ-019 NAVY
- PSQ-020 OYSTER
- PSQ-021 PEARL OYSTER
- PSQ-022 PELICAN
- PSQ-023 ROYAL
- PSQ-024 RUBY
- PSQ-025 SEA WHITE
- PSQ-026 SMOKE
- PSQ-027 TEAL
- PSQ-029 TOO WHITE
- PSQ-030 WHITE ICE

1 1/2" Channels (PSP-xxx)	YARD	10 YARDS	ROLL
Non-Pleated (PSQ-xxx)	70.00	30.00	27.50

SIERRA SOFT

Superior Strength • Tough AND Soft • Hi-Loft Backing • Easily cleaned

MANUFACTURED TO MEET THE FOLLOWING CODES:

- Motor Vehicle Safety Standard 302
- California Tech Bulletin 117

FINISHES and TREATMENTS:

- Abrasion - heavy duty (Wyzenbeek/CFFA-1)
- UV stabilized pigments
- Mildew resistant backing and face
- Heat sealable
- Cold Crack -10°F (-23.3°C)
- Light fastness: 300 hours minimum

SUITABLE APPLICATIONS:

- Office
- Residential
- Automotive

SPECIFICS:

- Width: 54"
- Weight: 29 Oz.
- Yards Per Roll: 30



- SIS-5944 BRIAR BROWN
- SIS-6260 DARK BLUE
- SIS-6262 COGNAC
- SIS-6339 BEECHWOOD
- SIS-6526 DARK RED
- SIS-6611 LIGHT GREY
- SIS-6690 MED. BEIGE
- SIS-6691 LIGHT NEUTRAL
- SIS-7184 MED. DARK PEWTER
- SIS-9562 BLACK
- SIS-9563 OFF WHITE

- SIS-9564 FLAME RED
- SIS-9565 MEDIUM BROWN
- SIS-9566 GARNET
- SIS-9567 BROWN
- SIS-9570 BUCKSKIN
- SIS-9572 RUST
- SIS-9577 DARK MAPLE
- SIS-9578 CHARCOAL
- SIS-9580 MEDIUM GREY
- SIS-9581 DARK SAPPHIRE
- SIS-9870 ROYAL

Width: 54"	YARD	10 YDS	30 YDS
	33.30	30.00	27.50

HIGH-LOFT² BACKING SOFTSIDE THE AUTOMOTIVE COLLECTION

SIMTEX

Superior Strength • Tough AND Soft • Hi-Loft Backing • Easily cleaned

MANUFACTURED TO MEET THE FOLLOWING CODES:

- Motor Vehicle Safety Standard 302
- California Tech Bulletin 117

FINISHES and TREATMENTS:

- Abrasion - heavy duty: Wyzenbeek/CFFA-1
- Heat sealable
- Cold Crack -10 F
- Light fastness: 300 hours minimum
- UV stabilized pigments

SUITABLE APPLICATIONS

- Office
- Residential
- Automotive



SPECIFICS

- Width: 54"
- Weight: 29 ozs.
- Yards Per Roll: 30

SIM-076207 PLATA
SIM-076217 FRENCH VANILLA
SIM-077715 ZEUS BLACK
SIM-077717 BEIGE

Width: 54" YARD 45.00 15 YDS 40.50 30 YDS 37.10

High-Loft² BACKING SOFTSIDE THE AUTOMOTIVE COLLECTION

SOHO

Superior Strength • Tough AND Soft • Hi-Loft Backing • Easily cleaned

MANUFACTURED TO MEET THE FOLLOWING CODES:

- California T.B. 117-2013
- FMVSS 302
- IMO FTP 2010 Code MSC.307(88) Part 8: 3.1 & 3.2
- NFPA 260- Cover Fabric – Class I
- UFAC Fabric – Class I

FINISHES and TREATMENTS:

- PVC with an Acrylic Topcoat
- Abrasion - heavy duty: Wyzenbeek/CFFA-1
- Heat sealable
- Cold Crack -10 F
- Light fastness: 300 hours minimum
- UV stabilized pigments

SUITABLE APPLICATIONS

- Office
- Residential
- Automotive
- Restaurant
- Hospitality
- Commercial



SPECIFICS

- Width: 54"
- Weight: 28 ozs.
- Yards Per Roll: 30

CHARACTERISTICS

- Formaldehyde Free
- No Heavy Metals
- Sulfide Stain Resistant
- Superior Abrasion: 50,000 cycles | Wyzenbeek #10 Cotton Duck

UV Stabilized Pigments: Xenotest: AATCM Blue Wool | 1,000 hours

Cold Crack: -10°F

Exclusively Interiors

SOH-7525 CHARCOAL BLACK
SOH-7526 LIGHT STONE
SOH-7688 CAMEL
SOH-7689 MED. LIGHT STONE
SOH-7707 LIGHT CAMEL

Width: 54" YARD 33.30 15 YDS 30.00 30 YDS 27.50

Hi-Loft flex SOFTSIDE THE AUTOMOTIVE COLLECTION

STRATOSPHERE

MANUFACTURED TO MEET THE FOLLOWING CODES:

- Motor Vehicle Safety Standard 302
- California Tech Bulletin 117 Section E
- Class Ratings: ASTM D 4157 - Class A

FINISHES and TREATMENTS:

- Abrasion - 100,000 Wyzenbeek
- Heat sealable • Cold Crack -20 F
- Mildew resistant backing & and face
- UV stabilized pigments: 500 hours minimum
- Anti-bacterial and anti-fungal: Pass*
- Anti-stain

SUITABLE APPLICATIONS:

- Marine
- Residential
- Automotive • RV
- Spas • Massage tables
- Conference room • Office
- Lounge seating

SPECIFICS:

- Width: 54"
- Weight: 28 ozs.
- Thickness: 1.10mm
- Yards Per Roll: 30

PERMABLOK³
ADVANCED VINYL PROTECTION



Cleaning Instructions:
This product should be cleaned with mild soap and water. Do not use alcohol based cleaners!

STR-2401 TURQUOISE
STR-2402 CONCRETE
STR-2403 CHARCOAL
STR-2404 ICE BLUE
STR-2405 MYSTIC BLUE
STR-2406 COBALT
STR-2407 GRASS
STR-2408 COPPER
STR-2409 PUMPKIN
STR-2410 POPPY
STR-2411 BORDEAUX
STR-2412 TAUPE
STR-2413 MOSS
STR-2414 BRONZE
STR-2415 ESPRESSO

Width: 54" YARD 48.20 10 YDS 43.40 30 YDS 39.80

High-Loft² BACKING SOFTSIDE THE FURNITURE COLLECTION

SUTTON

Superior Strength • Tough AND Soft • Hi-Loft Backing • Easily cleaned

MANUFACTURED TO MEET THE FOLLOWING CODES:

- California T.B. 117-2013
- FMVSS 302
- IMO FTP 2010 Code MSC.307(88) Part 8: 3.1 & 3.2
- NFPA 260- Cover Fabric – Class I
- UFAC Fabric – Class I

FINISHES and TREATMENTS:

- PVC with an Acrylic Topcoat
- Abrasion - heavy duty: Wyzenbeek/CFFA-1
- Heat sealable
- Cold Crack -10 F
- Light fastness: 300 hours minimum
- UV stabilized pigments

SUITABLE APPLICATIONS

- Office
- Residential
- Automotive
- Restaurant
- Hospitality
- Commercial



SPECIFICS

- Width: 54"
- Weight: 28 ozs.
- Yards Per Roll: 30

CHARACTERISTICS

- Formaldehyde Free
- No Heavy Metals
- Sulfide Stain Resistant
- Superior Abrasion: 50,000 cycles | Wyzenbeek #10 Cotton Duck

UV Stabilized Pigments: Xenotest: AATCM Blue Wool | 1,000 hours

Cold Crack: -10°F

Exclusively Interiors

SUT-7302 TAUPE
SUT-7332 DARK SLATE GRAY
SUT-7333 SANDSTONE
SUT-7426 MEDIUM KHAKI
SUT-7457 MEDIUM SLATE
SUT-7556 BLACK

Width: 54" YARD 33.30 15 YDS 30.00 30 YDS 27.50

Hi-Loft flex SOFTSIDE THE AUTOMOTIVE COLLECTION

TORINO

Superior Strength • Tough AND Soft • Hi-Loft Backing • Easily cleaned

MANUFACTURED TO MEET THE FOLLOWING CODES:

- California T.B. 117-2013
- FMVSS 302
- IMO FTP 2010 Code MSC.307(88) Part 8: 3.1 & 3.2
- NFPA 260- Cover Fabric – Class I
- UFAC Fabric – Class I

FINISHES and TREATMENTS:

- PVC with an Acrylic Topcoat
- Abrasion - heavy duty: Wyzenbeek/CFFA-1
- Heat sealable
- Cold Crack -10 F
- Light fastness: 300 hours minimum
- UV stabilized pigments

SUITABLE APPLICATIONS

- Office
- Residential
- Automotive
- Restaurant
- Hospitality
- Commercial



SPECIFICS

- Width: 54"
- Weight: 28 ozs.
- Yards Per Roll: 30

CHARACTERISTICS

- Formaldehyde Free
- No Heavy Metals
- Sulfide Stain Resistant
- Superior Abrasion: 50,000 cycles | Wyzenbeek #10 Cotton Duck

UV Stabilized Pigments: Xenotest: AATCM Blue Wool | 1,000 hours

Cold Crack: -10°F

Exclusively Interiors

TOR-7459 LIGHT GRAYSTONE

Width: 54"	YARD	15 YDS	30 YDS
	33.30	30.00	27.50

Hi-Loft flex **SOFTSIDE**
THE AUTOMOTIVE COLLECTION

TREXX MET MQ

MANUFACTURED TO MEET THE FOLLOWING CODES:

- IMO FTP 2010 Code MSC.307(88) Part 8, 3.1 & 3.2
- California Tech Bulletin #117-2013
- Motor Vehicle Safety Standard 302
- UFAC - Class 1
- NFPA 260 - Class 1

SPECIFICS:

- Width: 54" (137cm)
- Weight: 29 oz. (656gm/m²)
- Yards Per Roll: 30 (27.43m)

THE FINISHES & TREATMENTS:

- Antimicrobial and antibacterial protection
- Antistain finish • Easily cleaned
- Mildew resistant backing and face
- Superior abrasion resistance 50,000 cycles - Wyzenbeek/CFFA-1 Fed Standard 191 - A Method 5304
- Cold Crack -10 degrees F (-28.9C)
- Heat sealable • UV stabilized pigments
- Oil resistant backing and face
- Sulfide Stain Resistant / All colors

SUITABLE APPLICATIONS • Contract • Marine • Automotive • Hospitals • Hotel/Motel

SEQUEL IS MADE WITH

Spradling's NAPA TOPCOAT FINISH

- TRE-1501 Hail
- TRE-1502 Nectar
- TRE-1503 Convoy
- TRE-1504 Blade
- TRE-1505 Sentry



- TRE-1506 Night Watch
- TRE-1507 Gear
- TRE-1508 Merigold
- TRE-1509 Blace
- TRE-1510 Captain
- TRE-1511 Putty

Width: 54"	YARD	10 YDS	30 YDS
	38.50	34.70	31.80

HIGH-LOFT² BACKING **SOFTSIDE**
THE MARINE COLLECTION

VERONA

Superior Strength • Tough AND Soft • Hi-Loft Backing • Easily cleaned

MANUFACTURED TO MEET THE FOLLOWING CODES:

- California T.B. 117-2013
- FMVSS 302
- IMO FTP 2010 Code MSC.307(88) Part 8: 3.1 & 3.2
- NFPA 260- Cover Fabric – Class I
- UFAC Fabric – Class I

FINISHES and TREATMENTS:

- PVC with an Acrylic Topcoat
- Abrasion - heavy duty: Wyzenbeek/CFFA-1
- Heat sealable
- Cold Crack -10 F
- Light fastness: 300 hours minimum
- UV stabilized pigments

SUITABLE APPLICATIONS

- Office
- Residential
- Automotive
- Restaurant
- Hospitality
- Commercial



SPECIFICS

- Width: 54"
- Weight: 28 ozs.
- Yards Per Roll: 30

CHARACTERISTICS

- Formaldehyde Free
- No Heavy Metals
- Sulfide Stain Resistant
- Superior Abrasion: 50,000 cycles | Wyzenbeek #10 Cotton Duck

UV Stabilized Pigments: Xenotest: AATCM Blue Wool | 1,000 hours

Cold Crack: -10°F

Exclusively Interiors

- VER-7482 CHARCOAL BLACK
- VER-7483 CAMEL
- VER-7528 MED. LIGHT STONE
- VER-7731 GRAYSTONE
- VER-7787 STEEL GRAY

Width: 54"	YARD	15 YDS	30 YDS
	33.30	30.00	27.50

Hi-Loft flex **SOFTSIDE**
THE AUTOMOTIVE COLLECTION

WALLABY SOFT

MANUFACTURED TO MEET THE FOLLOWING CODES:

- Motor Vehicle Safety Standard 302
- California Tech Bulletin 117 Section E

FINISHES and TREATMENTS:

- Superior Abrasion
- Anti-static
- Cold Crack -10 F • QUV: 650 hours

SUITABLE APPLICATIONS:

- General seating
- General sewn products
- Auto • RV

SPECIFICS:

- Width: 54"
- Weight: 40 ozs./In.yd.
- Yards Per Roll: 30



- WAS-9860 BLACK
- WAS-9861 GREY
- WAS-9863 DARK GREEN

Width: 54"	YARD	10 YDS	30 YDS
	33.30	30.00	27.50

HIGH-LOFT² BACKING **SOFTSIDE**
THE AUTOMOTIVE COLLECTION

WHISPER

MANUFACTURED TO MEET THE FOLLOWING CODES:

- BIFMA Class A
- UFAC Class 1
- California Technical Bulletin #117 Section E
- Motor Vehicle Safety Standard 302

FINISHED and TREATMENTS:

- 4 Component Urethane Topcoating System
- Superior abrasion resistance 100,000 cycles Wyzenbeek/CFFA-1
- Mildew Resistant Front & Back
- UV stabilized pigments
- Light fastness / 1000 Hours

GENERAL CHARACTERISTIC:

- Ultrasoft leather feel
- Excellent tailorability
- Superior wear resistance
- Soft Hi-Loft² backing

SPECIFICS:

- Width: 54"
- Weight: 27oz.
- Yards Per Roll: 30

SUITABLE APPLICATIONS:

- Contract Interiors
- Restaurant
- Residential
- Patios
- Automotive
- RV
- Office
- Hotel/Motel
- Sunrooms
- Hospitals
- Marine
- Nursing Homes

WHISPER IS MADE WITH

Spradling's NAPA TOPCOAT FINISH

Spradling's Napa Finish is a waxy urethane topcoat which provides superior abrasion resistance.

Napa topcoat possesses a soft hand intended for a comfortable, elegant leather experience but durable hand to withstand elements such as erosion caused by scratching, rubbing, and natural wear-&-tear.

Whisper combines the luxurious feel and look of soft supple leather with outstanding wear-resistant properties demanded in commercial seating applications.

A proprietary formulation which includes multiple top-coating systems, Whisper provides a scuff-resistant surface that achieves 100,000 "double rubs" and the waxy, genuine feel of leather.

Unlike many of the softer leather-look vinyls now on the market, Whisper offers both a soft surface feel, and excellent wear-resistant properties!

Whisper offers a color palette of 28 modern decorator colors from solids to perfect blends of subtle variation, providing understated elegance.



Whisper

WHI-2116 BRILLIANT WHITE	WHI-2128 NIGHTSHADE	WHI-2140 BLACK	WHI-2157 FOG
WHI-2117 BONE	WHI-2129 FORREST	WHI-2141 CASHEW	WHI-2158 CUCUMBER
WHI-2118 CAMEL	WHI-2130 KHAKI	WHI-2142 COGNAC	WHI-2159 ZEST
WHI-2119 GRAVEL	WHI-2131 GREEN TEA	WHI-2143 ESPRESSO	WHI-2160 SASSAFRAS
WHI-2120 ANTELOPE	WHI-2132 CAVERN MOSS	WHI-2144 SANGRE	WHI-2161 MALLARD
WHI-2121 CAPPUCCINO	WHI-2133 LODEN	WHI-2150 FAWN	WHI-2162 PARADISE
WHI-2122 SISAL	WHI-2134 PATINA	WHI-2151 OCHRE	WHI-2163 INDIGO
WHI-2123 LUGGAGE	WHI-2135 ANTHRACITE	WHI-2152 MAHOGANY	WHI-2164 CAROTENE
WHI-2124 SALSA	WHI-2136 CERULEAN	WHI-2153 TRUFFLE	WHI-2165 MOLTEN
WHI-2125 CINNAMON	WHI-2137 NAVY	WHI-2154 PEWTER	WHI-2166 BRICK-RED
WHI-2126 BORDEAUX	WHI-2138 ELEPHANT	WHI-2155 STORM	
WHI-2127 MERLOT	WHI-2139 CHARCOAL	WHI-2156 PUTTY	

Width: 54"	YARD	10 YDS	30 YDS
	42.90	38.70	36.60

HIGH-LOFT² BACKING SOFTSIDE THE FURNITURE COLLECTION

ZANDER

MANUFACTURED TO MEET THE FOLLOWING CODES:

- BIFMA
- California Tech Bulletin #117
- Motor Vehicle Safety Standard 302
- UFAC - Class 1

SPECIFICS:

- Width: 54" (137cm)
- Weight: 34 oz. (770gm/m²)
- Yards Per Roll: 30 (27.43m)

FINISHES & TREATMENTS:

- Antimicrobial and antibacterial protection
- Antistain finish • Easily cleaned
- Mildew resistant backing and face
- Superior abrasion resistance 100,000 cycles - Wyzenbeek/CFFA-1 Federal Standard 191 - A Method 5304
- Antistatic slip finish
- Cold Crack -10 degrees F (-28.9C)
- Heat sealable
- UV stabilized pigments
- Oil resistant backing and face
- Sulfide stain resistant / all colors

SUITABLE APPLICATIONS:

- Contract Interiors
- Office
- Restaurant
- Hotel/Motel
- Residential
- Sunrooms
- Patios
- Hospitals
- Nursing Homes
- Automotive
- Marine
- RV



PERMAGUARD®
SUPERIOR STAIN RESISTANCE

ZAN-3102 PURE WHITE	ZAN-3114 YELLOW
ZAN-3103 BRILLIANT WHITE	ZAN-3115 APRICOT
ZAN-3104 OFF WHITE	ZAN-3116 PAPAYA
ZAN-3105 WHITE CAP	ZAN-3117 CHERRY
ZAN-3101 IVORY	ZAN-3118 OCHRE
ZAN-3106 CREAM	ZAN-3119 BURGUNDY
ZAN-3107 LIGHT YELLOW	ZAN-3120 MOCCA
ZAN-3108 PARCHMENT	ZAN-3121 AQUA MARINE
ZAN-3109 DUNE	ZAN-3122 MEDITERRANEE
ZAN-3110 ARCTIC SKY	ZAN-3123 TRUE BLUE
ZAN-3111 AUSTER	ZAN-3124 CELESTIAL
ZAN-3112 PEARL GREY	ZAN-3125 FOREST
ZAN-3113 DOVE GREY	ZAN-3126 BLACKBEARD

Width: 54"	YARD	10 YDS	30 YDS
	34.30	30.90	29.20

HIGH-LOFT² BACKING SOFTSIDE THE MARINE COLLECTION

ARMADA

PREMIUM VINYL COLLECTION with PRODURATECT™ M

ENDURATEX™

We cover the world.

MANUFACTURED TO MEET THE FOLLOWING CODES:

- California Technical Bulletin #117 Section E
- Motor Vehicle Safety Standard 302
- ASTM D 3690: Class A

(This term and any corresponding data refer to the typical performance in the specific tests indicated and should not be construed to imply the behavior of this or any other material under actual fire conditions.)

FINISHES and TREATMENTS:

- Heavy Duty Abrasion Resistance: Wyzenbeek
- Mildew Treated Front & Back
- Cold Crack: -10°
- QUV-B: 600 Hours
- Weathermeter: 1,500 Hours
- Anti-microbial and anti-bacterial
- Heat Sealable
- Antimicrobial: Pass

CLEANING

- Clean with mild soap and water.
- Do not use alcohol based cleaners.

SPECIFICS

- Width: 54"
- Weight: 30oz
- Thickness: 1.02mm
- Yards Per Roll: 40



SUITABLE APPLICATIONS:

- Office Interior
- Restaurant
- Gaming
- Marine Interior
- Motel
- Hospitality
- Health Care
- Residential
- RV
- Hotel

Treated with anti-bacterial and antimicrobial agents that will provide resistance to the following: (AATCC Test Method 147-1993)

- Bacillus Mycoides
- Klebsiella Pneumoniae
- Proteus Vulgaris
- Staphylococcus Aureus
- Salmonella Choleraesuis
- Bacillus Cerus
- Enterococcus Faecalis
- Escherichia Coli

- ARM-100 ATLANTIC MIST
- ARM-101 BALTIC
- ARM-102 BISCAY IVORY
- ARM-103 BREAKWATER
- ARM-104 ENSIGN
- ARM-105 FIESTA
- ARM-106 FIRE ISLAND
- ARM-107 ISLAND PALM
- ARM-108 LEMON CHIFFON
- ARM-109 MARINER
- ARM-110 MONTEGO
- ARM-111 MYSTIC
- ARM-112 NAUTILUS
- ARM-113 PERFECT STORM
- ARM-114 PORTSIDE
- ARM-115 PURPLE HAZE
- ARM-116 RED SAIL
- ARM-117 SAND DOLLAR
- ARM-118 SAND DUNE
- ARM-119 SAND BEACH
- ARM-120 SANGRIA
- ARM-121 SEASCAPE
- ARM-122 SHALLOW WATER
- ARM-123 SUGAR CANE
- ARM-124 SUMMER SUN
- ARM-125 SUNSET
- ARM-126 TSUNAMI

	YARD	10 YDS	25 YDS
Width: 54"	29.00	24.50	21.10

ASPIRATIONS

PREMIUM VINYL COLLECTION with PRODURATECT™ C

ENDURATEX™

We cover the world.

MANUFACTURED TO MEET THE FOLLOWING CODES:

- California Tech Bulletin #117 Sec E
- Motor Vehicle Safety Standard 302
- Federal Aviation Specification FAR 25.853(a)
- Boston Fire Department Code
- Port Authorities of New York and New Jersey
- NFPA 260 Class 1
- CID A-A2950
- BIFMA Class A
- UFAC - Class A
- ASTM D 3690 - Class A
- Anti Bacterial/Anti Microbial Passes NYS63/ASTM G-21-90

SPECIFICS:

- Width: 54" (137cm)
- Weight: 26 oz. per lin.yd.
- Yards Per Roll: 30 (27.43m)
- Backing: Brush Knit

SUITABLE APPLICATIONS:

- Office Interior
- Restaurant
- Gaming
- Marine Interior
- Hospitality
- Health Care
- Residential
- RV

CLEANING

- Clean with mild soap and water.
- Do not use alcohol based cleaners.



FINISHES & TREATMENTS:

- Superior abrasion resistance 100,000 cycles - Wyzenbeek/#10 cotton duck
- Cold Crack: -10 Degrees F
- Thickness 1.1mm
- UV stabilized pigments 500hrs min.
- Polyester backing
- Heat Sealable

Treated with anti-bacterial and antimicrobial agents that will provide resistance to the following: (AATCC Test Method 147-1993)

- Bacillus Mycoides
- Klebsiella Pneumoniae
- Proteus Vulgaris
- Staphylococcus Aureus
- Salmonella Choleraesuis
- Bacillus Cerus
- Enterococcus Faecalis
- Escherichia Coli

- ASP-100 AKA
- ASP-1000 JESSAMY
- ASP-1100 LEAK
- ASP-1200 MILK CHOCOLATE
- ASP-1300 OCHER
- ASP-1400 OLIVAREOUS
- ASP-1500 PECAN SHELL
- ASP-1600 PUMICE
- ASP-1700 SADDLE
- ASP-1800 SANGUINE
- ASP-1900 SHALE
- ASP-200 BLACK BEAN
- ASP-2000 TAN
- ASP-2100 TANGELLO
- ASP-2200 TEAK
- ASP-300 CELESTE
- ASP-400 CLOUD
- ASP-500 CRIMSON
- ASP-600 FLAN
- ASP-700 FLAXSEED
- ASP-800 FUCHSIA
- ASP-900 INDIGO

	YARD	10 YDS	30 YDS
Width: 54"	42.40	35.80	30.80

BERWICK TWEED

MANUFACTURED TO MEET THE FOLLOWING CODES:

- BIFMA Class A
- California Tech Bulletin #117
- Federal Aviation Specification FAR 25.853(a)
- Boston Fire Code
- Port Authorities of New York and New Jersey
- Motor Vehicle Safety Standard
- NFPA 260 Class 1
- CID A-A2950
- UFAC - Class A

SPECIFICS:

- Width: 54" (137cm)
- Weight: 25 oz.
- Yards Per Roll: 30
- Contents: PVC
- Backing: Brushed Knit

FINISHES & TREATMENTS:

- Abrasion resistance 100,000 cycles - Wyzenbeek/CFFA-1 Federal Standard 191 - A Method 5304
- Cold Crack -10 degrees F
- Thickness 1.2mm
- UV stabilized pigments
- Polyester backing

Treated with anti-bacterial and antimicrobial agents that will provide resistance to the following: (AATCC Test Method 147-1993)

- Bacillus Mycoides
- Klebsiella Pneumoniae
- Proteus Vulgaris
- Staphylococcus Aureus
- Salmonella Choleraesuis
- Bacillus Cerus
- Enterococcus Faecalis
- Escherichia Coli



PREMIUM VINYL COLLECTION with PRODURATECT™ c

ENDURATEX™

We cover the world.

- BRW-1300 RACCOON EYES
- BRW-1400 SANDY TOES
- BRW-1500 SEA GLASS
- BRW-1600 SOFT SUEDE
- BRW-1700 SPIKED APRICOT
- BRW-1800 THAI BASIL
- BRW-1900 TRANQUILITY
- BRW-200 ALL NIGHTER
- BRW-2000 ZEN ESSENCE
- BRW-300 ANGELS FEATHER
- BRW-400 BAJA SUNSET
- BRW-500 BODHI TREE
- BRW-600 CARBON FOOTPRINT
- BRW-700 CEDAR RIDGE
- BRW-800 DREAM CATCHER



- BRW-100 AFTER GLOW
- BRW-1000 MISCHIEVOUS MINK
- BRW-1100 BOBCAT WHISKER
- BRW-1200 POLISHED PEWTER

• Clean with mild soap and water. • Do not use alcohol based cleaners

Width: 54"	YARD	10 YDS	30 YDS
	49.70	41.90	36.10

BRITISH STERLING WITH FORBID

MANUFACTURED TO MEET THE FOLLOWING CODES:

- BIFMA Class A
- California Tech Bulletin #117
- Federal Aviation Specification FAR 25.853(a)
- Boston Fire Code
- Port Authorities of New York and New Jersey
- Motor Vehicle Safety Standard
- NFPA 260 Class 1
- CID A-A2950
- UFAC - Class A

SPECIFICS:

- Width: 54" (137cm)
- Weight: 30 oz.
- Yards Per Roll: 30
- Contents: 100% Virgin Vinyl
- Backing: Q1

FINISHES & TREATMENTS:

- Abrasion-100,000 cycles Wyzenbeek/#8 Cotton duck
- Cold Crack -10 degrees F
- Thickness 1.1mm
- UV stabilized pigments 500 hrs min.
- Mildew Resistant
- Heat Sealable

Treated with anti-bacterial and antimicrobial agents that will provide resistance to the following: (AATCC Test Method 147-1993)

- Bacillus Mycoides
- Klebsiella Pneumoniae
- Proteus Vulgaris
- Staphylococcus Aureus
- Salmonella Choleraesuis
- Bacillus Cerus
- Enterococcus Faecalis
- Escherichia Coli



SUITABLE APPLICATIONS:

- Office Interior
- Restaurant
- Gaming
- Marine Interior
- Hospitality
- Health Care
- Residential
- RV

Cleaning Instructions:

This product should be cleaned with mild soap and water. Do not use alcohol based cleaners!



ENDURATEX™

We cover the world.

- BRS-100 BLUE HEATH
- BRS-1000 AMETHYST
- BRS-1100 CALERA
- BRS-1200 BOWEN RED
- BRS-1300 ERICA
- BRS-1400 SMOKE
- BRS-1500 SAND
- BRS-1600 DUCK EGG
- BRS-200 GRANITE
- BRS-300 HEATHER
- BRS-400 JEANS BLUE
- BRS-500 LICHEN GREEN
- BRS-600 SANDSTONE
- BRS-700 SLATE
- BRS-800 TARN BLUE
- BRS-900 TORMENTIL

Q1
BACKING

Width: 54"	YARD	10 YDS	30 YDS
	45.40	38.30	33.00

BRUSHED ALUMINUM

MANUFACTURED TO MEET THE FOLLOWING CODES:

- Motor Vehicle Safety Standard 302
- California Tech Bulletin 117 Section E
- Class Ratings: ASTM D 3690 - Class A

FINISHES and TREATMENTS:

- Abrasion - heavy duty
- Heat sealable • Cold Crack -10 F
- Mildew resistant backing & and face
- UV stabilized pigments: 500 hours min
- Anti-bacterial and anti-microbial: Pass*

SUITABLE APPLICATIONS:

- Marine
- Residential
- Automotive • RV
- Spas • Massage tables
- Conference room • Office
- Lounge seating

SPECIFICS:

- Width: 54"
- Weight: 33 ozs.
- Thickness: 1.10mm



PREMIUM VINYL COLLECTION with PRODURATECT™ A

ENDURATEX™

We cover the world.

- ALU-100 BLACK
- ALU-200 GOLD
- ALU-300 SILVER
- ALU-400 LIME GREEN
- ALU-500 BURGUNDY

Cleaning Instructions:

This product should be cleaned with mild soap and water. Do not use alcohol based cleaners!

Width: 54"	YARD	10 YDS	30 YDS
	39.90	35.90	32.10



CARBON FIBER

PREMIUM VINYL COLLECTION with PRODURATEX™ A

MANUFACTURED TO MEET THE FOLLOWING CODES:

- Motor Vehicle Safety Standard 302
- California Tech Bulletin 117 Section E
- Class Ratings: ASTM D 3690 - Class A

FINISHES and TREATMENTS:

- Abrasion - heavy duty: Wyzenbeek 100,000 cycles #8 cotton duck
- Heat sealable • Cold Crack -10 F
- Mildew resistant backing & and face
- UV stabilized pigments: 500 hours minimum
- Anti-bacterial and anti-microbial: Pass*

SPECIFICS:

- Width: 54"
- Weight: 33 ozs.
- Thickness: 1.02mm
- Yards Per Roll: 30



SUITABLE APPLICATIONS:

- Marine
- Residential
- Automotive • RV
- Spas • Massage tables
- Conference room • Office
- Lounge seating

CLEANING:

This product should be cleaned with mild soap and water. Do not use alcohol based cleaners!

- CAR 100 CLASSIC BLACK
- CAR 1000 PERFORMANCE PURPLE
- CAR 1100 RALLY BRIGHT WHITE
- CAR 1200 CRUISER COPPER
- CAR 1300 ACCELERATION BLUE
- CAR 200 QUICK SILVER
- CAR 300 STOP LIGHT RED
- CAR 400 CAUTION YELLOW
- CAR 500 RACY BLUE
- CAR 600 OVERDRIVE CHARCOAL
- CAR 700 COMPETITION ORANGE
- CAR 800 FINISH LINE PEARL
- CAR 900 BLUE STREAK

Width: 54"	YARD	10 YDS	30 YDS
	38.50	34.60	31.00



CHAIN MAILLE WITH FORBID



MANUFACTURED TO MEET THE FOLLOWING CODES:

- Motor Vehicle Safety Standard 302
- California Tech Bulletin 117 Section 1
- NFPA 260, Class 1
- BIFMA, Class A
- UFAC, Class 1

FINISHES and TREATMENTS:

- Abrasion - heavy duty: Wyzenbeek 100,000 cycles #8 cotton duck
- Cold Crack -10 F
- Mildew resistant backing & and face
- UV stabilized pigments: 300 hours min.
- Anti-bacterial and anti-microbial: Pass*

SUITABLE APPLICATIONS:

- Marine
- Residential
- Automotive • RV
- Restaurant
- Conference room • Office
- Lounge seating

SPECIFICS:

- Width: 54"
- Weight: 30 ozs.
- Thickness: 1.0mm
- Yards Per Roll: 30

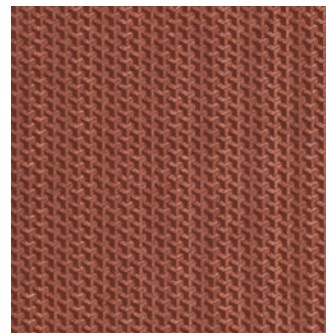

CHM-200: COPPER COIN

- CHM-200 COPPER COIN
- CHM-203 BRONZE SHIELD
- CHM-206 SILVER RING
- CHM-209 GILDEN GUANTLET
- CHM-212 BRASS CHALICE
- CHM-215 BLUE STEEL
- CHM-218 FORGED IRON
- CHM-221 BLACK KNIGHT

Width: 54"	YARD	10 YDS	30 YDS
	57.10	51.40	46.00

COASTAL RANCH WITH FORBID

- Superior Strength
- Hi-Loft Backing

- Tough & Soft
- Easily Cleaned

MANUFACTURED TO MEET THE FOLLOWING CODES:

- Motor Vehicle Safety Standard 302
- California Tech Bulletin 117 Section E-2013
- NFPA 260, Class 1
- BIFMA, Class A
- UFAC, Class 1



FINISHES and TREATMENTS:

- Abrasion - 100,000 Wyzenbeek/CFFA-1
- Mildew Resistant: Front & Back
- Heat sealable
- Cold Crack -20 F
- Light fastness: 300 hours minimum
- UV stabilized pigments
- Oil & Sulphide Stain Resistant
- Anti-Bacterial/Anti Microbial (NYS63/ASTM G-21-90)

SUITABLE APPLICATIONS

- Office
- Residential
- Automotive

SPECIFICS

- Width: 54"
- Weight: 34 ozs.
- Thickness: 1.1mm
- Yards Per Roll: 30

- COA-4100 ALOE GARDEN
- COA-4105 AMBER DUST
- COA-4110 BEACH BUOYS
- COA-4115 BEACH PEBBLE
- COA-4120 BELL ROCK
- COA-4125 BLANK CANVAS
- COA-4130 BLISSFUL BANYAN
- COA-4135 CUBAN CIGAR
- COA-4140 ENCHANTED EGGPLANT
- COA-4150 HANAUMA BAY
- COA-4145 HEART THROB
- COA-4160 ICE CREAM FLOAT
- COA-4165 KEY STONE
- COA-4170 MOROCCAN SUNSET
- COA-4175 NOT-YO-CHEESE
- COA-4180 PAW PRINTS
- COA-4155 SECRET COVE
- COA-4190 SUMMER HUE
- COA-4185 SWEET GINSENG
- COA-4195 TREE POSE
- COA-4197 EBONY

Anti-bacterial and anti-microbial treatment:

* These products have been treated with anti-bacterial and anti-microbial agents which will provide resistance to the following: (AATCC Test Method 147-147-1993)

- Bacillus Mycoides
- Klebsiella Pneumoniae
- Proteus Vulgaris
- Staphylococcus Aureus
- Salmonella Choleraesuis
- Bacillus Cerus
- Enterococcus Faecalis
- Escherichia Coli

Width: 54"	YARD	15 YDS	30 YDS
	40.60	36.60	32.70

COUNTERPANE

PREMIUM VINYL COLLECTION with PRODURATECT™ M

MANUFACTURED TO MEET THE FOLLOWING CODES:

- Motor Vehicle Safety Standard 302
- California Tech Bulletin 117 Section E-2013
- NFPA 260, Class 1
- BIFMA, Class A
- UFAC, Class A
- CID A-A-2950
- Class Ratings ASTM D 3690 - Class A

FINISHES and TREATMENTS:

- Abrasion - 100,000 Wyzenbeek/CFFA-1
- Mildew Resistant: Front & Back
- Cold Crack -10 F
- Light fastness: 500 hours minimum
- UV stabilized pigments
- Anti-Bacterial/Anti Microbial (AATCC 147 / ASTM G-21)

SUITABLE APPLICATIONS

- Office
- Residential
- Massage Tables
- Lounge Seating
- Conference Rooms
- Marine

SPECIFICS

- Width: 54"
- Weight: 30 ozs.
- Thickness: 1.05mm
- Yards Per Roll: 30



- CTP-904 ALMOND CREAM
- CTP-511 ANTIQUE TAUPE
- CTP-509 BRIQUETTE
- CTP-902 BRUIN BLUE
- CTP-901 CARDINAL
- CTP-512 DARK CHERRY
- CTP-908 EBONY
- CTP-508 GREYSTONE
- CTP-907 MIST
- CTP-507 NAVY
- CTP-905 OFF WHITE
- CTP-909 PEARL
- CTP-903 SAND DOLLAR
- CTP-906 SNOW
- CTP-510 TROLLEY GREY

Anti-bacterial and anti-microbial treatment:
* These products have been treated with anti-bacterial and anti-microbial agents which will provide resistance to the following: (AATCC Test Method 147-147-1993)

- Bacillus Mycoides
- Klebsiella Pneumoniae
- Proteus Vulgaris
- Staphylococcus Aureus
- Salmonella Choleraesuis
- Bacillus Cerus
- Enterococcus Faecalis
- Escherichia Coli

Width: 54"	YARD	15 YDS	30 YDS
	55.50	46.80	40.30

CRIANZA

PREMIUM VINYL COLLECTION with PRODURATECT™ C

MANUFACTURED TO MEET THE FOLLOWING CODES:

- Motor Vehicle Safety Standard 302
- California Tech Bulletin 117
- BIFMA Class A
- NFPA 2160 Class 1
- FAA-FAR 25.853B
- CID A-A-2950
- BS 5852:2006 Clause II
- IMO 652(16) 8.2 & 8.3

SPECIFICS:

- Width: 54" (137 cm)
- Weight: 34oz. (770gm/m)
- Roll Size: 30yds
- Content: PU/PVC
- Backing: 100% Polyester Microfiber

FINISHES AND TREATMENTS:

- PRODURATECT C®
- Abrasion - heavy duty: 100,000 cycles - Wyzenbeek/CFFA-1
- Cold Crack -20°F (-28.9C)
- UV stabilized pigments 500 Hours

Treated with anti-bacterial and antimicrobial agents that will provide resistance to the following: (AATCC Test Method 147-1993)

- Bacillus Mycoides
- Klebsiella Pneumoniae
- Proteus Vulgaris
- Staphylococcus Aureus
- Salmonella Choleraesuis
- Bacillus Cerus
- Enterococcus Faecalis
- Escherichia Coli



CLEANING

- Clean with mild soap and water.
- Do not use alcohol based cleaners

- CRI-100 AMBER
- CRI-1000 MAHOGANY
- CRI-1100 MOSS
- CRI-1200 RASIN
- CRI-1300 RUSSET
- CRI-1400 TAUPE
- CRI-1500 OXFORD
- CRI-1600 MILITARY
- CRI-1700 CITRON
- CRI-1800 CHARCOAL
- CRI-200 BISCOTTI
- CRI-300 BLACK BEAUTY
- CRI-400 BRICK
- CRI-500 BURGUNDY
- CRI-600 DIJON
- CRI-700 GRAPE LEAF
- CRI-800 HARVEST
- CRI-900 JAVA

Width: 54"	YARD	10 YDS	30 YDS
	77.10	65.00	56.00

EL CAPITAN

HEAVY WEIGHT

MANUFACTURED TO MEET THE FOLLOWING CODES:

- Motor Vehicle Safety Standard 302
- California Tech Bulletin 117 Section E

FINISHES and TREATMENTS:

- Abrasion: Wyzenbeek
- Cold Crack -40 F
- UV stabilized pigments: 300 hours minimum

SPECIFICS:

- Width: 54" (Heidi 61")
- Weight: 44 ozs.
- Thickness: 1.02mm
- Yards Per Roll: 20
- 100% Virgin Vinyl

SUITABLE APPLICATIONS:

- RV
- Marine
- Automotive
- Residential

CLEANING

- Clean with mild soap and water.
- Do not use alcohol based cleaners

ENDURATEX™
We cover the world.

- ELC-3100 COLONIAL BLACK
- ELC-3101 MADRID BLACK
- ELC-3102 COLONIAL ANTIQUE BROWN
- ELC-3103 COLONIAL DARK GREEN

Width: 54"	YARD	10 YDS	20 YDS
	45.80	41.20	36.90

GRAN RESERVA

PREMIUM VINYL COLLECTION with PRODURATECT™ C

MANUFACTURED TO MEET THE FOLLOWING CODES:

- Motor Vehicle Safety Standard 302
- California Tech Bulletin 117 Section D
- BIFMA Class A
- NFPA 260 Class 1
- FAA-FAR 25.853B
- CID A-A-2950
- UFCA Class 1

FINISHES and TREATMENTS:

- Polyurethane / PVC face
- Polyester Microfiber backing
- Abrasion- heavy duty: Wyzenbeek 100,000 cycles #8 cotton duck
- Cold Crack -10 F
- Mildew resistant backing and face
- UV stabilized pigments: 500 hours minimum
- Anti-bacterial and anti-microbial: Pass*

SUITABLE APPLICATIONS:

- Residential • Office
- Hospitality • Healthcare
- Restaurant • Gaming
- Marine • Auto • RV

SPECIFICS:

- Width: 54"
- Weight: 34 ozs.
- Yards Per Roll: 30
- Backing: Polyester Micro Fiber



ENDURATEX™
We cover the world.



- GRS 2647 CHATEAU
- GRS 2651 CELLAR BROWN
- GRS 2646 CANTINA RUST
- GRS 2645 SAIL ORANGE
- GRS 2652 STONE GROUND MUSTARD
- GRS 2644 ANGELICA GOLD
- GRS 2643 MUSCATEL
- GRS 2648 AUBERGINE
- GRS 2650 BLACK BEAUTY
- GRS 2642 GRAPE LEAF
- GRS 2649 MALBEC
- GRS 2641 THOMPSON GREEN
- GRS2653 ASH
- GRS2654 CITRON
- GRS2655 MILITARY

Anti-bacterial and anti-microbial treatment:

* These products have been treated with anti-bacterial and anti-microbial agents which will provide resistance to the following: (AATCC Test Method 147-147-1993)

- Bacillus Mycoides
- Klebsiella Pneumoniae
- Proteus Vulgaris
- Staphylococcus Aureus
- Salmonella Choleraesuis
- Bacillus Cerus
- Enterococcus Faecalis
- Escherichia Coli

Cleaning Instructions:

This product should be cleaned with mild soap and water. Do not use alcohol based cleaners!

Width: 54"	YARD	10 YDS	30 YDS
	58.40	52.60	47.00

GRAND VISTA WITH FORBID.

MANUFACTURED TO MEET THE FOLLOWING CODES:

- Motor Vehicle Safety Standard 302
- California Tech Bulletin 117 Section E
- Class Ratings: ASTM D 3690 - Class A
- FAR 25.853
- Federal Specification CCC-A-680-A
- Boston Fire Department Code
- Port Authority of NY and NJ

FINISHES and TREATMENTS:

- Abrasion - heavy duty: Wyzenbeek 100,000 cycles
- Heat sealable • Cold Crack -10 F
- Mildew resistant backing & and face
- UV stabilized pigments: 500 hours minimum
- Anti-bacterial (NYS63/ASTM G-90) Pass
- Anti-microbial (NYS63/ASTM G-90) Pass

SUITABLE APPLICATIONS:

- Conference room
- Office • Executive seating
- Residential • Home office
- Hospitality • Healthcare
- Spas • Massage tables
- Lounge seating
- Automotive • RV

SPECIFICS:

- Width: 54" (137cm)
- Weight: 36 oz.
- Thickness: 1.24mm
- Yards Per Roll: 30
- 100% Virgin Vinyl
- Backing: Polyester Knit



ENDURATEX™
We cover the world.

- GRV 001 ALMOND
- GRV 002 AZURE
- GRV 003 BLACK
- GRV 004 CHARCOAL
- GRV 005 CHESTNUT
- GRV 006 CHOCOLATE
- GRV 007 COLONIAL BLUE
- GRV 008 CRANBERRY
- GRV 009 FIRE RED
- GRV 010 NAVY
- GRV 011 OXBLOOD
- GRV 012 SPICE
- GRV 013 SUEDE
- GRV 014 TEAL
- GRV 015 WHEAT

Anti-bacterial and anti-microbial treatment:

* These products have been treated with anti-bacterial and anti-microbial agents which will provide resistance to the following: (AATCC Test Method 147-147-1993)

- Bacillus Mycoides
- Klebsiella Pneumoniae
- Proteus Vulgaris
- Staphylococcus Aureus
- Salmonella Choleraesuis
- Bacillus Cerus
- Enterococcus Faecalis
- Escherichia Coli

CLEANING INSTRUCTIONS:

Method One: For most common stains and spills, use mild soap and water.
Method Two: If method one doesn't work, use the below house hold items: Fantastik, 409, or Mr Clean.
Method Three: For tougher stains such as sharpie, paint and lipstick, use a 70% Isopropyl Alcohol Wipe.

Width: 54"	YARD	10 YDS	30 YDS
	43.80	39.40	35.30

INDEPENDENCE 2 WITH FORBID

ENDURATEX™
We cover the world.

MANUFACTURED TO MEET THE FOLLOWING CODES:

- Motor Vehicle Safety Standard 302
- California Tech Bulletin 117 Section E
- Class Ratings: ASTM D 3690 - Class A

FINISHES and TREATMENTS:

- Abrasion - heavy duty: Wyzenbeek 100,000 cycles #8 cotton duck
- Heat sealable • Cold Crack -10 F
- Mildew resistant backing and face
- UV stabilized pigments: 500 hours minimum
- Anti-bacterial: Pass
- Anti-microbial: Pass
- Oil and sulfide resistant

SUITABLE APPLICATIONS:

- Conference room
- Executive seating
- Residential
- Hospitality
- Massage tables
- Lounge seating
- Automotive
- Contract
- Office
- Home office
- Healthcare
- Spas
- Restaurants
- RV

SPECIFICS:

- Width: 54" (137cm)
- Weight: 32 oz.
- Thickness: 1.02mm
- Yards Per Roll: 30
- 100% Virgin Vinyl
- Backing: Polyester Knit

CLEANING INSTRUCTIONS:

Method One: For most common stains and spills, use mild soap and water.
Method Two: If method one doesn't work, use the below house hold items: Fantastik, 409, or Mr Clean.
Method Three: For tougher stains such as sharpie, paint and lipstick, use a 70% Isopropyl Alcohol Wipe.

Treated with anti-bacterial and antimicrobial agents that will provide resistance to the following: (AATCC Test Method 147-1993)

- Bacillus Mycoides
- Klebsiella Pneumoniae
- Proteus Vulgaris
- Staphylococcus Aureus
- Salmonella Choleraesuis
- Bacillus Cereus
- Enterococcus Faecalis
- Escherichia Coli



- IND 8402 VISCAYA PALM
- IND 8403 COLONIAL BLUE
- IND 8404 GRAPE
- IND 8405 ESPRESSO
- IND 8406 MOCHA
- IND 8407 SUPER WHITE
- IND 8408 PLATINUM
- IND 8411 TURQUOISE
- IND 8413 SNOW WHITE
- IND 8414 COFFEE CREAM
- IND 8415 LEMON PEEL
- IND 8417 CHINA GREEN
- IND 8419 MIDNIGHT BLUE
- IND 8420 MOONSTONE
- IND 8421 SUNFLOWER
- IND 8501 ADOBE
- IND 8527 LIPSTICK
- IND 8528 AMERICAN BEAUTY
- IND 8532 BORDEAUX
- IND 8540 BLACK
- IND 8541 SPACE BLUE
- IND 8542 ROYAL BLUE
- IND 8545 OCEAN GRAY
- IND 8549 SPRUCE
- IND 8550 CELENDON GREEN
- IND 8553 YEW GREEN
- IND 8558 TOMATO

- IND 8564 GROTTO
- IND 8565 TEA ROSE
- IND 8567 DOVE
- IND 8569 BURGUNDY
- IND 8571 FORREST GREEN
- IND 8576 DEEP PHOENICIAN
- IND 8584 TAUPE
- IND 8601 ACADEMY BLUE
- IND 8605 BROWN SUGAR
- IND 8606 CAMEL
- IND 8607 CHOCOLATE
- IND 8608 CINNAMON
- IND 8610 COPPER
- IND 8614 DARK PLUM
- IND 8615 DUTCH ORANGE
- IND 8516 CHESTNUT
- IND 8616 FRANCISCAN GRAY
- IND 8619 GUNMETAL

- IND 8620 JADE
- IND 8621 LEAF GREEN
- IND 8622 LODEN
- IND 8624 LIGHT MAPLE
- IND 8625 MANDARIN
- IND 8626 NAVY
- IND 8627 PAPRIKA
- IND 8628 PARCHMENT
- IND 8629 PETAL
- IND 8634 SAND
- IND 8602 AERO BLUE
- IND 8603 ALABASTER
- IND 8604 AZURE BLUE
- IND 8609 CLAY
- IND 8611 CORNSILK
- IND 8612 COSMOS
- IND 8613 CRESCENT CHERRY
- IND 8617 FRENCH BROWN
- IND 8618 GREENERY
- IND 8623 LIGHT LIME
- IND 8630 QUAIL
- IND 8631 RASBERRY
- IND 8632 REGAL
- IND 8633 ROSETAN
- IND 8635 SHELL
- IND 8636 SUMER HAZE
- IND 8637 TAWNY

Width: 54"	YARD	10 YDS	30 YDS
	32.80	29.50	26.40

JETSTREAM

PREMIUM VINYL COLLECTION with PRODURATECT™ M

MANUFACTURED TO MEET THE FOLLOWING CODES:

- Motor Vehicle Safety Standard 302
- California Tech Bulletin 117 Section E
- Class Ratings: ASTM D 3690 - Class A

FINISHES and TREATMENTS:

- Abrasion - heavy duty
- Heat sealable • Cold Crack -10 F
- Mildew resistant backing and face
- UV Stabilized pigments: 500 hours minimum
- Anti-bacterial and anti-microbial: Pass*
- Oil and sulfide resistant

SPECIFICS

- Width: 54"
- Weight 30 ozs.
- Thickness: 1.10mm
- Yards Per Roll: 30

CLEANING

- Clean with mild soap and water.
- Do not use alcohol based cleaners.



- SUITABLE APPLICATIONS:**
- Marine
 - Residential
 - Automotive • RV
 - Spas • Massage tables
 - Conference room • Office
 - Lounge seating

- JET 001 BLUE TURQUOISE
- JET 002 BONANZA GOLD
- JET 003 BRILLIANT BRONZE
- ~~JET 004 CITRUS ORANGE~~
- JET 005 COOL BLUE
- JET 006 COPPER PENNY
- JET 007 CRYSTAL WATER
- JET 008 DIAMOND JUBILEE
- JET 009 RETRO RED
- JET 010 GLOWING FLAME
- JET 011 GOLD RUSH
- JET 012 IMPERIAL GREEN
- ~~JET 013 JUST PEACHY~~

- JET 014 LILAC SHIMMER
- JET 015 LIME GREEN
- JET 016 LONE STAR SILVER
- JET 017 MAJESTIC PURPLE
- JET 018 MINT GREEN
- JET 019 BLACK PEARL
- ~~JET 020 RADIANT ROSE~~
- ~~JET 021 RUBY RED~~
- JET 022 SAFFRON YELLOW
- JET 023 SUMMER LIGHTNING
- ~~JET 024 SUN CORAL~~
- JET 025 SUNSHINE YELLOW JET
- ~~JET 026 SUPREME AZURE~~

Width: 54"	YARD	10 YDS	30 YDS
	41.00	36.90	33.00



ENDURATEX'S STAIN RESISTANT TOPCOAT

The Enduralex Forbid Challenge is ON!

Go where no vinyl has gone before....

Forbid topcoat takes Enduralex vinyl to the next level of excellence providing maximum stain resistance and protection! Forbid will resist stains like:

- Lipstick
- Ink
- Paint
- Liquid
- Crayons

Take the Forbid Challenge!

FORBID, the recently developed topcoat by Enduralex, delivers a topcoat for enduring beauty and performance for vinyl products. More than two decades in the making, Forbid is a topcoat created by Enduralex for vinyl products.

Even though vinyl is inherently more cleanable than other fabrics and has long been known for superior performance, some stains are hard to repel or get out. That's where Forbid comes in! 20 years in the making, Forbid topcoat dramatically increases stain resistance, while preserving the integrity of the fabric luster and softness.

Traditionally difficult stains and spills, like ink, paint and lipstick are no match for Forbid!

Enduralex is known for providing superior vinyl coated fabrics to the automotive, hospitality, marine, healthcare and spa industries.



ENDURATEX™
We cover the world.



CLEANING INSTRUCTIONS

Method One: For most common stains and spills, use mild soap and water

Method Two: If method one doesn't work, use the below house hold items.

- FANTASTIK
- 409
- MR. CLEAN

Method Three: For tougher stains such as sharpie, paint and lipstick, use a 70% isopropyl alcohol wipe

Staining Agent	Method One:	Method Two:	Method Three:
DIRT	✘	✘	
PEN MARKS	✘	✘	
SHARPIE			✘
PAINT			✘
KETCHUP & MUSTARD			✘
LIPSTICK			✘
NAILPOLISH			✘

See it in Action!
<http://forbidprt.com>



LIGHTHOUSE

FINISHES and TREATMENTS:

- Anti-microbial treated
(Specific tests available upon request)
- Mildew treated
- Cold Crack -10 degrees F
- UV stabilized pigments: 500 hour min.
- Weatherometer: 1500 hours minimum

SPECIFICS:

- Width: 54" (137cm)
- Weight: 28 oz. / lineal yard
- Thickness: 0.97mm
- Yards Per Roll: 40 (00.00m)
- Backing: Polyester Knit

LIGHTHOUSE

SUITABLE APPLICATIONS:

- Marine
- Residential

Cleaning Instructions:

- *This product should be cleaned with mild soap and water.*
- *Do not use alcohol based cleaners!*



ENDURATEX™
We cover the world.

- LIT 4919 ALMOND
- LIT 4920 IVORY
- LIT 4921 GRAY
- LIT 4922 SNOW WHITE
- LIT 4923 OFF WHITE

Width: 54"	YARD 24.00	10 YDS 20.40	40 YDS 17.30
-------------------	----------------------	------------------------	------------------------



LONGITUDE

PREMIUM VINYL COLLECTION with PRODURATECT™ A

MANUFACTURED TO MEET
THE FOLLOWING CODES:

- California Tech Bulletin #117
- Motor Vehicle Safety Standard 302
- Class Ratings: ASTM D 3690 - Class A

FINISHES and TREATMENTS:

- Heat Sealable
- Abrasion - Heavy Duty Wyzenbeek
- Cold Crack -10 degrees F
- UV stabilized pigments: 300 hour min.

SPECIFICS:

- Width: 54" (137cm)
- Weight: 30 oz. / lineal yard
- Thickness: 1.02mm
- Yards Per Roll: 30
- 100% Virgin Vinyl

SUITABLE APPLICATIONS:

- RV/Automotive
- Residential Seating
- Office/General Seating

Cleaning Instructions:

*This product should be cleaned with mild soap and water.
Do not use alcohol based cleaners!*

ENDURATEX™
We cover the world.

- LNG-167A EBONY
- LNG-311N LIGHT TITANIUM
- LNG-313N DARK TITANIUM
- LNG-260M MOROCCO
- LNG-830K LIGHT CASHMERE

Width: 54"	YARD	10 YDS	40 YDS
	36.80	31.10	26.80



LUNAR

PREMIUM VINYL COLLECTION with PRODURATECT™ M

MANUFACTURED TO MEET
THE FOLLOWING CODES:

- California Tech Bulletin #117
- Motor Vehicle Safety Standard 302

SPECIFICS:

- Width: 54" (137cm)
- Weight: 26 oz.
- Yards Per Roll: 30
- Content: PVC
- Backing: Polyester Brushed Knit

FINISHES & TREATMENTS:

- Antimicrobial and antibacterial protection
- Mildew resistant backing and face
- Heavy Duty Wyzenbeek/
- Cold Crack -10degrees F • Heat sealable
- UV stabilized pigments 500 hours min
- Class Rating ASTM D 3690 Class A

Treated with anti-bacterial and antimicrobial agents that will provide resistance to the following: (AATCC Test Method 147-1993)

- Bacillus Mycoides
- Klebsiella Pneumoniae
- Proteus Vulgaris
- Staphylococcus Aureus
- Salmonella Choleraesuis
- Bacillus Cerus
- Enterococcus Faecalis
- Escherichia Coli

SUITABLE APPLICATIONS:

- Conference Rooms • Office
- Massage Tables • Lounge Seating
- Automotive • Marine • RV



ENDURATEX™
We cover the world.

- LUN-100 MED NEUTRAL
- LUN-1000 SEA SALT
- LUN-1100 HARBOR GRAY
- LUN-1200 MILITARY BLUE
- LUN-1300 TAHITI REEF
- LUN-1400 BURGUNDY
- LUN-200 DK PEWTER
- LUN-300 MED FLINT
- LUN-400 BLACK
- LUN-500 WHITE
- LUN-600 STINGER CREAM
- LUN-700 AMERICAN BEAUTY
- LUN-800 MOONLITE
- LUN-900 STINGER BISQUE

Width: 54"	YARD	10 YDS	30 YDS
	46.20	38.90	33.50



OSSIE

PREMIUM VINYL COLLECTION with PRODURATECT™ C

MANUFACTURED TO MEET
THE FOLLOWING CODES:

- California Tech Bulletin #117
- Motor Vehicle Safety Standard 302
- Class Ratings: ASTM D 3690 - Class A

SPECIFICS:

- Width: 54" (137cm)
- Weight: 26 oz. per li.yd.
- Yards Per Roll: 30 (27.43m)

Clean with mild soap and water. Do not use alcohol based cleaners

SUITABLE APPLICATIONS:

- Conference Rooms • Office
- Massage Tables • Lounge Seating
- Automotive • Marine • RV

FINISHES & TREATMENTS:

- Antimicrobial and antibacterial protection
- Mildew resistant backing and face
- Heavy Duty Wyzenbeek/#8 cotton duck
- Cold Crack -10degrees F • Heat sealable
- UV stabilized pigments 500 hours min

Treated with anti-bacterial and antimicrobial agents that will provide resistance to the following: (AATCC Test Method 147-1993)

- Bacillus Mycoides
- Klebsiella Pneumoniae
- Proteus Vulgaris
- Staphylococcus Aureus
- Salmonella Choleraesuis
- Bacillus Cerus
- Enterococcus Faecalis
- Escherichia Coli



ENDURATEX™
We cover the world.

- OSS-100 BARK
- OSS-1000 SYRAH
- OSS-1100 TAUPE
- OSS-1200 TERRA COTTA
- OSS-1300 SEA CLIFF
- OSS-200 CAMEL
- OSS-300 CAPRICE
- OSS-400 CLOUD
- OSS-500 EBONY
- OSS-600 FIR
- OSS-700 MAPLE
- OSS-800 PEBBLES
- OSS-900 SAND

Width: 54"	YARD	10 YDS	30 YDS
	42.20	38.00	34.00



PHANTOM PERFORATED

Superior Strength • Tough AND Soft • Easily cleaned

MANUFACTURED TO MEET THE FOLLOWING CODES:

- Motor Vehicle Safety Standard 302
- California Tech Bulletin 117
- UFAC- Class 1

FINISHES and TREATMENTS:

- Abrasion - heavy duty: Wyzenbeek/CFFA-1 50,000 cycles
- Heat sealable
- Cold Crack -10 F
- Light fastness: 300 hours minimum
- UV stabilized pigments
- Mildew Resistance

SUITABLE APPLICATIONS

- Automotive
- Office
- Residential
- Hospitality
- Healthcare
- Restaurant

SPECIFICS

- Width: 54"
- Weight: 33 oz.
- Yards Per Roll: 30



- PHT-001 BLACK
- PHT-500 BLACK/BLACK
- PHT-501 BLACK/RED
- PHT-502 BLACK/BLUE
- PHT-503 BLACK/WHITE
- PHT-504 BLACK/YELLOW
- PHT-505 BLACK/TURF
- PHT-506 BLACK/ORANGE
- PHT-507 BLACK/GREEN

Width: 54"	YARD 41.10	15 YDS 37.00	30 YDS 33.10
------------	----------------------	------------------------	------------------------

PRIZM WITH FORBID

ENDURATEX™

We cover the world.

MANUFACTURED TO MEET THE FOLLOWING CODES:

- Motor Vehicle Safety Standard 302
- California Tech Bulletin 117 Section E
- Class Ratings: ASTM D 3690 - Class A
- FAR 25.853
- Federal Specification CCC-A-680-A
- Boston Fire Department Code
- Port Authority of NY and NJ

FINISHES and TREATMENTS:

- Abrasion - heavy duty: Wyzenbeek 100,000 cycles
- Heat sealable • Cold Crack -10 F
- Mildew resistant backing & face
- UV stabilized pigments: 500 hours minimum
- Anti-bacterial (NYS63/ASTM G-90) Pass
- Anti-microbial (NYS63/ASTM G-90) Pass

SUITABLE APPLICATIONS:

- Conference room
- Office • Executive seating
- Residential • Home office
- Hospitality • Healthcare
- Spas • Massage tables
- Lounge seating

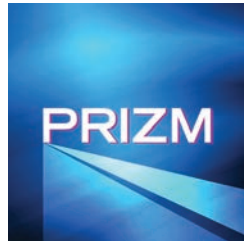

SPECIFICS:

- Width: 54" (137cm)
- Weight: 36 oz.
- Thickness: 1.24mm
- Yards Per Roll: 30
- 100% Virgin Vinyl
- Backing: Polyester Knit

PRZ 001 ALLSPICE	PRZ 020 PORT
PRZ 002 BLACK	PRZ 021 ROYAL BLUE
PRZ 003 BLACK PLUM	PRZ 022 SLATE
PRZ 004 BURGUNDY	PRZ 023 SPECTRA ROYAL BLUE
PRZ 005 CANDY APPLE	PRZ 024 TOMATO
PRZ 006 BLUE JAY	PRZ 025 SNOW WHITE
PRZ 007 CAMELBACK	PRZ 026 WHITE
PRZ 008 COFFEE CREAM	PRZ-027 AMERICAN BEAUTY
PRZ 009 COLONIAL BLUE	PRZ-028 GREENERY
PRZ 010 CORDOVAN	PRZ-029 WINEBERRY
PRZ 011 DEEP CLAY	PRZ-030 TURQUOISE
PRZ 012 GRAY	PRZ-031 DARK BROWN
PRZ 013 HUNTER GREEN	PRZ-032 DUCKEGG
PRZ 014 JADE	PRZ-033 OLIVE
PRZ 015 MARINE	PRZ-034 RASBERRY
PRZ 016 NAVY	PRZ-035 SAND
PRZ 017 NEW BURGUNDY	PRZ-036 APPLE
PRZ 018 OUTBACK	PRZ-037 LUPIN BLUE
PRZ 019 PURPLE IRIS	

Anti-bacterial and anti-microbial treatment:

* These products have been treated with anti-bacterial and anti-microbial agents which will provide resistance to the following: (AATCC Test Method 147-147-1993)

- Bacillus Mycoides
- Klebsiella Pneumoniae
- Proteus Vulgaris
- Staphylococcus Aureus
- Salmonella Choleraesuis
- Bacillus Cerus
- Enterococcus Faecalis
- Escherichia Coli

Width: 54"	YARD 42.10	10 YDS 37.90	30 YDS 33.90
------------	----------------------	------------------------	------------------------

SOHO WITH FORBID

ENDURATEX™

We cover the world.

MANUFACTURED TO MEET THE FOLLOWING CODES:

- Motor Vehicle Safety Standard 302
- California Tech Bulletin 117
- UFAC- Class 1
- BIFMA - Class A

FINISHES and TREATMENTS:

- Abrasion - heavy duty: Wyzenbeek/CFFA-1
- Cold Crack -10 F
- Light fastness: 300 hours minimum
- UV stabilized pigments

- Width: 54"
- Weight: 32 oz.
- Thickness: 1.02mm
- Yards Per Roll: 30
- 100% Virgin Vinyl

SUITABLE APPLICATIONS:

- Conference room
- Office • Executive seating
- Residential • Home office
- Hospitality
- Lounge seating

- SOHO-7689 MED. LT. STONE
- SOHO-7526 LT. STONE
- SOHO-7525 CHARCOAL BLACK
- SOHO-7707 LT. CAMEL

Width: 54"	YARD 36.60	15 YDS 30.90	30 YDS 26.60
------------	----------------------	------------------------	------------------------

SURREY

PREMIUM VINYL COLLECTION with PRODURATECT™ C

MANUFACTURED TO MEET THE FOLLOWING CODES:

- Motor Vehicle Safety Standard 302
- California Tech Bulletin 117
- New York & New Jersey Port Authority
- NFPA 260 Class 1
- FAA-FAR 25.853
- CID A-A-2950
- BIFMA Class A
- UFAC Class A



ENDURATEX™
We cover the world.

SPECIFICS:

- Width: 54" (137 cm)
- Weight: 28oz.
- Yards Per Roll: 30
- Content: PVC
- Backing: Diamond Soft Knit

FINISHES AND TREATMENTS:

- PRODURATECT C®
- Abrasion - heavy duty: 100,000 cycles - Wyzenbeek/CFFA-1
- Cold Crack -20°F (-28.9C)
- UV stabilized pigments

CLEANING:

- Clean with mild soap and water.
- Do not use alcohol based cleaners

Anti-Bacterial and Anti-Microbial Treatment:
Treated with anti-bacterial and anti-microbial agents which will provide resistance to the following:
(AATCC Test Method 147-147-1993)

- Bacillus Mycoides
- Klebsiella Pneumoniae
- Proteus Vulgaris
- Staphylococcus Aureus
- Salmonella Choleraesuis
- Bacillus Cerus
- Enterococcus Faecalis
- Escherichia Coli



- SUR-1000 AGED TEAK
- SUR-1100 BEAR HUG
- SUR-1200 BIRDS NEST
- SUR-1300 BUDDING FERN
- SUR-1400 DUSTY PLUM
- SUR-1500 EXOTIC ESCAPE
- SUR-1600 FALL CANYON
- SUR-1700 FIRE CORAL
- SUR-1800 GARDEN GATE
- SUR-1900 GRAY SPELL
- SUR-2000 HI DEF LIME
- SUR-2100 LEMON SPLASH
- SUR-2200 MERMAID TAIL
- SUR-2300 NORTH RIM
- SUR-2400 ORIGAMI
- SUR-2500 PALOMINO
- SUR-2600 PRISMATIC SPRING
- SUR-2700 RAIN DANCE
- SUR-2800 SUN KISSED
- SUR-2900 TIGER MOTH

Width: 54"	YARD	10 YDS	30 YDS
	54.30	45.80	39.40

TRADEWINDS PLUS WITH FORBID.

ENDURATEX™
We cover the world.

TRADEWINDS PLUS

MANUFACTURED TO MEET THE FOLLOWING CODES:

- Motor Vehicle Safety Standard 302
- California Tech Bulletin 117 Section E
- Class Ratings: ASTM D 3690 - Class A

FINISHES and TREATMENTS:

- Abrasion - heavy duty: Wyzenbeek 100,000 cycles #8 cotton duck
- Heat sealable • Cold Crack -10 F
- Mildew resistant backing & and face
- UV stabilized pigments: 500 hours minimum
- Anti-bacterial and anti-microbial: Pass*

SPECIFICS:

- Width: 54"
- Weight: 32 ozs.
- Thickness: 1.02mm
- Yards Per Roll: 30

CLEANING INSTRUCTIONS:

- Method One: For most common stains and spills, use mild soap and water.
- Method Two: If method one doesn't work, use the below house hold items: Fantastik, 409, or Mr Clean.
- Method Three: For tougher stains such as sharpie, paint and lipstick, use a 70% Isopropyl Alcohol Wipe.

SUITABLE APPLICATIONS:

- Marine
- Residential
- Automotive • RV

- | | |
|----------------------------------|----------------------------------|
| TRA 6600 ALEUTIAN | TRA 6634 BLUSH |
| TRA 6602 ARCTIC FROST | TRA 6635 BRANDY |
| TRA 6603 BAHAMA | TRA 6636 CASCADE PINE |
| TRA 6604 BLACK SEA | TRA 6637 DEEP SUNTAN |
| TRA 6606 CARIBBEAN | TRA 6638 GENTIAN BLUE |
| TRA 6608 CARNIVAL | TRA 6639 GOLDEN DAWN |
| TRA 6610 COASTAL SAND | TRA 6640 HARBOR NIGHT |
| TRA 6611 COCONUT BARK | TRA 6641 LAGUNA SURF |
| TRA 6612 TANGELO | TRA 6642 LIVELY LEAF |
| TRA 6614 DEEP LAGOON | TRA 6643 MANDALAY |
| TRA 6615 DELTA BLUE | TRA 6644 MONTE CARLO |
| TRA 6617 HARBOR GREY | TRA 6645 POMONA PLUM |
| TRA 6618 HAWAIIAN | TRA 6646 REGAL VIOLET |
| TRA 6620 MOON MISTY | TRA 6647 TIARA BLUE |
| TRA 6622 PACIFIC MIST | TRA 6648 ULTRA WHITE |
| TRA 6623 POLAR DUSK | TRA 7701 DOLPHIN |
| TRA 6624 PORPOISE | TRA 7708 IVORY COAST |
| TRA 6627 SUNKISS | TRA 7711 MIDNIGHT SURF |
| TRA 6628 SUNSET RED | TRA 7716 SANDPOINTE |
| TRA 6629 TROPICAL PUNCH | TRA 7717 SEA FROST |
| TRA 6630 ULTRAMARINE | TRA 7718 STORMY |
| TRA 6631 ABYSS | TRA 7719 SEASHELL |
| TRA 6632 AURORA PEACH | TRA 7720 PEARL |
| TRA 6633 AZURE | |

Width: 54"	YARD	10 YDS	30 YDS
	35.00	31.50	28.20



VAQUERO

MANUFACTURED TO MEET THE FOLLOWING CODES:

- Motor Vehicle Safety Standard 302
- California Tech Bulletin 117, Section 1
- Class Rating: ASTM D3690 Class A
- BIFMA Class A
- UFAC Class 1
- NPFA 260 Class A

SPECIFICS

- Width: 54"
- Weight: 30 ozs.
- Yards Per Roll: 30

FINISHES and TREATMENTS:

- Abrasion - heavy duty: Wyzenbeek 100,000 cycles #10 Cotton Duck
- Heat sealable
- Cold Crack -10 F
- Light fastness: 300 hours minimum
- UV stabilized pigments: 300 hours min
- Face Contents: PVC
- Backing: Q1 Polyester
- Mildew Resistance Front & Back
- Anti-Bacterial/Anti-Microbial (AATCC 147 / ASM G-21)

SUITABLE APPLICATIONS

- Office
- Residential
- RV
- Conference Room
- Executive Seating
- Hospitality
- Lounge Seating
- Healthcare
- Restaurant Seating



- VAQ-1000 Apple Jack
- VAQ-1004 Blue Roan
- VAQ-1008 Chaparral
- VAQ-1012 Concha
- VAQ-1016 Creekside
- VAQ-1020 Hematite
- VAQ-1024 Jasper
- VAQ-1028 Lariat
- VAQ-1032 Mesquite
- VAQ-1036 Night Rider
- VAQ-1040 Pyrite
- VAQ-1044 Quartz
- VAQ-1048 Whitest White

Width: 54"	YARD 51.70	15 YDS 46.80	30 YDS 42.50
-------------------	----------------------	------------------------	------------------------

VERONA WITH FORBID

MANUFACTURED TO MEET THE FOLLOWING CODES:

- Motor Vehicle Safety Standard 302
- California Tech Bulletin 117
- UFAC - Class 1
- BIFMA - Class A

FINISHES and TREATMENTS:

- Abrasion - heavy duty: Wyzenbeek/CFFA-1
- Cold Crack -10 F
- Light fastness: 300 hours minimum
- UV stabilized pigments

- Width: 54"
- Weight: 32 oz.
- Thickness: 1.02mm
- Yards Per Roll: 30
- 100% Virgin Vinyl

SUITABLE APPLICATIONS:

- Conference room
- Office • Executive seating
- Residential • Home office
- Hospitality
- Lounge seating

ENDURATEX™

We cover the world.

- VER-7787 STEEL GRAY
- VER-7528 MED. LT. STONE
- VER-7483 CAMEL
- VER-7482 CHARCOAL BLACK
- VER-7731 GRAYSTONE

Width: 54"	YARD 36.60	15 YDS 30.90	30 YDS 26.60
-------------------	----------------------	------------------------	------------------------

WINDSONG 2 WITH FORBID

ENDURATEX™

We cover the world.

MANUFACTURED TO MEET THE FOLLOWING CODES:

- Motor Vehicle Safety Standard 302
- California Tech Bulletin 117 Section E
- Class Ratings: ASTM D 3690 - Class A

FINISHES and TREATMENTS:

- Abrasion - heavy duty: Wyzenbeek 100,000 cycles #8 cotton duck
- Heat sealable • Cold Crack -10 F
- Mildew resistant backing & and face
- UV stabilized pigments: 500 hours minimum
- Anti-bacterial and anti-microbial: Pass*

SUITABLE APPLICATIONS:

- Marine
- Residential
- Automotive • RV

CLEANING INSTRUCTIONS:

Method One: For most common stains and spills, use mild soap and water.

Method Two: If method one doesn't work, use the below house hold items: Fantastik, 409, or Mr Clean.

Method Three: For tougher stains such as sharpie, paint and lipstick, use a 70% Isopropyl Alcohol Wipe.

- SPECIFICS:**
- Width: 54"
 - Weight: 32 ozs.
 - Thickness: 1.02mm
 - Yards Per Roll: 30

- | | |
|------------------------------|--------------------------------|
| WIS 701 ALASKAN NIGHT | WIS 737 CAJUN SPICE |
| WIS 702 AQUA SPRAY | WIS 738 CUNCUN |
| WIS 704 ASIAN PLUM | WIS 739 CLOUD |
| WIS 706 CAPPUCCINO | WIS 740 FIRST LIGHT |
| WIS 707 CAYMAN BLUE | WIS 741 HIBISCUS |
| WIS 713 ICE WATER | WIS 742 HURRICANE BLACK |
| WIS 715 ISLAND SKY | WIS 743 INK |
| WIS 716 JAMAICAN SUN | WIS 744 KEY LIME |
| WIS 717 LIME COOLER | WIS 745 MARINE BLUE |
| WIS 718 LIPSTICK | WIS 746 NAUTICAL BLUE |
| WIS 719 MAUI SAND | WIS 747 SANGRIA |
| WIS 721 MOONBEAM | WIS 748 SEA SALT |
| WIS 722 OCEAN STORM | WIS 749 SUN GLOW |
| WIS 723 PALM GREEN | WIS 750 TROPICAL RED |
| WIS 724 POLAR BREEZE | WIS 751 FOG |
| WIS 727 ROYAL RED | WIS 752 WHITE CAP |
| WIS 731 ST. THOMAS DUSK | WIS 753 VANILLA CREAM |
| WIS 732 TAHITI REEF | WIS 754 BAJA TAN |
| WIS 733 TEAL WATERS | WIS 755 MALIBU SAND |
| WIS 735 BITTERSWEET | WIS 756 PEBBLE BEACH |
| WIS 736 BROWN RUM | WIS 757 PELICAN |

* These products have been treated with anti-bacterial and anti-microbial agents which will provide resistance to the following: (AATCC Test Method 147-147-1993)

- Bacillus Mycooides
- Klebsiella Pneumoniae
- Proteus Vulgaris
- Staphylococcus Aureus
- Salmonella Choleraesuis
- Bacillus Cerus
- Enterococcus Faecalis
- Escherichia Coli

Width: 54"	YARD 35.00	10 YDS 31.50	30 YDS 28.20
-------------------	----------------------	------------------------	------------------------



ENDURASOFT CORE WITH FORBID

Forbid is on All Patterns Except for Brush Aluminum & Carbon Fiber



BRUSHED ALUMINUM

- 100 BLACK
- 200 GOLD
- 300 SILVER
- 400 GREEN
- 500 BURGUNDY

CARBON FIBER

- 100 CLASSIC BLACK
- 200 QUICKSILVER
- 300 STOP LIGHT RED
- 400 CAUTION YELLOW
- 500 RACY BLUE
- 600 OVERDRIVE CHARCOAL
- 800 FINISH LINE PEARL
- 900 BLUE STREAK
- 1000 PERFORMANCE PURPLE
- 1100 RALLY BRIGHT WHITE
- 1200 CRUISER COPPER
- 1300 ACCELERATION BLUE

CHAINMAILLE

- 200 BLUE STEEL
- 203 BRASS CHALICE
- 206 BRONZE SHIELD
- 209 COPPER COIN
- 212 FORGED IRON
- 215 GILDED GAUNTLET
- 218 SILVER RING
- 221 BLACK KNIGHT

CORINTHIAN

- 0103 CHAR BLUE
- 0111 FRENCH VANILLA
- 3722 BLACK
- 4062 WHITE
- 6984 CAPPUCINO CREAM
- 7124 MEDIUM PEWTER
- 7180 MEDIUM DARK PEWTER
- 7182 LIGHT OAK
- 7292 EBONY

DOESKIN

- 4984 BLACK

ECLIPSE

- 001 INFINITY BLACK
- 003 WHITE HOT
- 004 VANILLA
- 005 REGAL BLUE
- 007 MERLOT
- 009 CHROME
- 010 ZINC
- 011 COFFEE BEAN
- 012 OFF WHITE
- 015 STRAW
- 016 PAPRIKA
- 017 BARLEY
- 018 TOFFEE
- 020 WINTER WHEAT
- 021 EXTREME GRAY

G GRAIN

- 7114 MEDIUM GRAPHITE
- 7119 LIGHT GRAPHITE
- 7227 EBONY
- 7357 MEDIUM FLINT
- 7390 LIGHT FLINT
- 7391 BLACK INK

HAMPTON

- 2616 SNOW
- 6439 GRANITE
- 6508 EBONY
- 6687 MEDIUM OPAL
- 6800 LAPIS BLUE
- 6884 TORCH RED
- 6962 SADDLE
- 6963 MEDIUM GRAPHITE

HAMPTON PERFORATED

- 2616 SNOW
- 6439 GRANITE
- 6508 EBONY
- 6687 MEDIUM OPAL
- 6800 LAPIS BLUE
- 6884 TORCH RED
- 6962 SADDLE
- 6963 MEDIUM GRAPHITE

HEIDI

- 5921 NAVY
- 6031 BURGUNDY
- 6106 SMOKE
- 6334 CINNABAR
- 6429 GRANITE
- 6430 CURRANT RED
- 6688 MEDIUM OPAL
- 6812 LAPIS BLUE
- 6952 MEDIUM GRAY
- 9840 BLACK
- 9917 SNOW WHITE

HONDA

- 537 GRAPHITE BLACK
- 6137 MOON LAKE

LUXOR

- 6784 EXCEL CHARCOAL
- 8801 BISQUE
- 8802 BLACK
- 8806 CREAM
- 8808 DOVE GRAY
- 8809 GRAPHITE
- 8814 SANDSTONE
- 8835 MOUNTAIN RIDGE

MADRID

- 2295 BLACK
- 2302 METALIC LT. BLUE
- 2309 MED. METALIC BLUE
- 4421 OFF WHITE
- 4470 MEDIUM BLUE
- 4513 DARK GREEN
- 4544 SADDLE
- 4769 BRIGHT RED
- 5013 DARK BROWN

MERCEDES

- 7313 ORION GRAY
- 7314 JAVA
- 4315 ANTHRACITE

MILLED PEBBLE

- 7360 LIGHT PARCHMENT
- 7396 DARK FLINT
- 7397 EBONY
- 7399 MEDIUM GRAPHITE
- 7400 MIDNIGHT BLACK
- 7404 OXFORD WHITE

MONTANA

- 6107 REGATTA BLUE
- 6110 SMOKE
- 6112 RAVEN
- 6244 SCARLET
- 6677 MEDIUM OPAL
- 7096 DARK GRAPHITE

MONTICELLO

- 6890 MEDIUM GRAY
- 6891 MEDIUM BEIGE
- 6892 GRAPHITE
- 6974 RUBY RED
- 7043 MEDIUM NEUTRAL
- 7178 MEDIUM DARK OAK
- 7286 BLACK
- 7323 SHALE
- 7346 VERY DARK PEWTER
- 7432 MEDIUM DARK PEWTER
- 7922 SNOW WHITE

NISSAN

- 7186 CAPRICE BLONDE

OXEN

- 0802 BROWN
- 0803 LIGHT BUCKSKIN
- 0815 METALIC BLUE
- 4560 BLACK
- 4568 MAROON
- 4853 WHITE
- 4957 DARK BUCKSKIN
- 5206 CARMINE
- 5959 BRIAR BROWN
- 5962 CHARCOAL GRAY

SIERRA

- 1714 METALIC LT. BLUE
- 1715 METALIC MED. BLUE
- 1720 PALOMINO
- 2929 METALIC LT. TURQUOISE
- 3718 WHITE
- 4956 BUCKSKIN
- 5818 CHARCOAL
- 6057 MEDIUM DARK GRAY
- 6060 LIGHT SADDLE
- 6121 GM DARK BLUE
- 6122 DARK CARMINE
- 6215 GARNET
- 6260 DARK BLUE
- 6261 DARK GRAY
- 6262 COGNAC
- 6339 BEECHWOOD
- 6526 DARK RED
- 6611 LIGHT GRAY
- 6758 LIGHT GRAY
- 6880 ADRIATIC BLUE
- 958 BLACK
- 958G BLACK (G)
- 9917 SNOW WHITE

SOHO

- 7689 MED. LT. STONE
- 7526 LIGHT STONE
- 7525 CHARCOAL BLACK
- 7707 LIGHT CAMEL

TOYOTA

- 6112 DARK CHARCOAL

VERONA

- 7787 STEEL GRAY
- 7528 MED. LT. STONE
- 7483 CAMEL
- 7482 CHARCOAL BLACK
- 7731 GRAYSTONE

WALLABY

- 5003 WHITE
- 5004 BLACK
- 5005 WEDGEWOOD BLUE
- 5006 LEATHER
- 5008 MAROON
- 5017 BLUE GREEN
- 5018 WALNUT
- 5213 CARMINE
- 5278 NAVY

MANUFACTURED TO MEET THE FOLLOWING CODES:

- Motor Vehicle Safety Standard 302
- California Tech Bulletin 117 Section E
- Class Ratings: A STM D 3690 - Class A



FINISHES and TREATMENTS:

- Abrasion - heavy duty: Wyzenbeek
- Heat sealable
- Cold Crack -10 F
- Mildew resistant backing and face
- UV stabilized pigments: 500 hours minimum
- Anti-bacterial and anti-microbial: Pass*

SUITABLE APPLICATIONS:

- Office
- Conference room
- Executive seating
- Residential
- Automotive • RV

SPECIFICS:

- Width: 54" (Heidi 61")
- Weight: 30 ozs.
- Thickness: 1.02mm
- Yards Per Roll: 30
- 100% Virgin Vinyl

ENDURATEX™
We cover the world.

CLEANING INSTRUCTIONS:

Method One: For most common stains and spills, use mild soap and water.

Method Two: If method one doesn't work, use the below house hold items: Fantastik, 409, or Mr Clean.

Method Three: For tougher stains such as sharpie, paint and lipstick, use a 70% Isopropyl Alcohol Wipe.

PREMIUM AUTOMOTIVE VINYL COLLECTION

	YARD	10 YDS	30 YDS
BRUSHED ALUMINUM	39.90	35.90	32.10
CARBON FIBER	38.50	34.60	31.00
CHAINMAILLE	38.50	34.60	31.00
CORINTHIAN	32.00	28.80	25.80
DOESKIN	29.80	26.80	24.00
ECLIPSE	35.50	32.00	28.60
G GRAIN	29.80	26.80	24.00
HAMPTON	29.80	26.80	24.00
HAMPTON PERFORATED	37.50	33.70	30.20
HEIDI	36.70	33.00	29.50
HONDA	29.80	26.80	24.00
LUXOR	29.80	26.80	24.00
MADRID	29.80	26.80	24.00
MERCEDES	29.80	26.80	24.00
MILLED PEBBLE	29.80	26.80	24.00
MONTANA	29.80	26.80	24.00
MONTICELLO	29.80	26.80	24.00
NISSAN	29.80	26.80	24.00
OXEN	29.80	26.80	24.00
SIERRA	29.80	26.80	24.00
SOHO	36.60	30.90	26.60
TOYOTA	29.80	26.80	24.00
VERONA	36.60	30.90	26.60
WALLABY	29.80	26.80	24.00

CASTILLO



Spills and Marks Wipe Away



MANUFACTURED TO MEET
THE FOLLOWING CODES:

- Motor Vehicle Safety Standard 302
- California Tech Bulletin 117 Section E
- NFPA 260 Class 1
- UFAC Class 1

FINISHES & TREATMENTS

- 100% Polyurethane
- Polyester Cotton 87/13 Backing
- Abrasion-Heavy Duty: Wyzenbeek
- ASTM 4157 200,000 double rubs
- Crocking: AATCC8 / Class 5 wet & dry
- Colorfastness to bleach: AATCC 130: Class 5

SPECIFICS

Width: 54"
Yard Per Roll: 10
Weight: 22.9oz

A New Polyurethane with i-clean technology



- Buff
- Honeydew
- Breezy
- Batik
- Red
- Clementine
- Cream
- Java
- Quarry
- Metal
- Steel
- Black
- White

Performance

i-clean™ is a high performance fabric specifically engineered for comfort and durability. Nanotechnology, utilizing a barrier finish, provides quick and easy cleaning.

Easy Maintenance

This stain resistant fabric is easily cleaned with water and mild soap. From common household spills to ink, i-clean™ utilizes technology that keeps furniture fresh and clean.

Environmentally Friendly
i-clean™ is made with environmentally friendly, water-based and low VOC chemicals. Our product stays cleaner longer and reduces the environmental impact caused by cleaning with harsh chemicals.

Finish: Antimicrobial – Silver based ion technology
I – clean – innovative easy clean technology

SUITABLE APPLICATIONS: Residential • Office • Hospitality • Healthcare • Restaurant • Gaming

Width: 54"	YARD	10 YDS	ROLL
	41.20	36.40	32.20

CANTINA

MANUFACTURED TO MEET
THE FOLLOWING CODES:

- Motor Vehicle Safety Standard #302
- California Tech Bulletin 117
- NFPA 260
- UFAC Class 1

SPECIFICS:

- Width: 54"
- Weight: 26 oz.
- 35 yard roll

SUITABLE APPLICATIONS

•Office •Commercial Seating •Residential •Marine •RV •Automotive

FINISHES & TREATMENTS:

- Abrasion: Highly Durable ASTM D 4157 Exceeds 100,00 double rubs•
- PVC Free
- Face Content: 100% Polyurethane
- Backing Content: 43% Recycled Leather, 40% Polyester, 17% Cotton

CLEANING

- *This product should be cleaned with mild soap and water.*
- *Do not use alcohol based cleaners!*



- PEANUT
- PUTTY
- TAUPE
- SADDLE
- CRANBERRY
- MAGNETITE
- MOLASSES
- CHILI

Width: 54"	YARD	10 YDS	35 YDS
	40.30	35.60	31.50

DILLON

MANUFACTURED TO MEET
THE FOLLOWING CODES:

- Motor Vehicle Safety Standard 302
- California Tech Bulletin 117
- NFPA 260 Class 1
- UFAC Class 1

SPECIFICS:

- Width: 54" (137 cm)
- Weight: 20.3oz.
- Roll Size: 30yds

SUITABLE APPLICATIONS

•Office •Commercial Seating •Residential •Marine •RV •Automotive

FINISHES & TREATMENTS:

- Content: 100% olyurethane.
- Backing: 70% Polyester, 30% Cotton
- PVC Free
- Antimicrobial
- Abrasion: Exceeds 200,000 Cycles

CLEANING

- *This product should be cleaned with mild soap and water.*
- *Do not use alcohol based cleaners!*

- JAVA
- LUGGAGE
- FIESTA
- CORDOVAN
- BUFF
- BLACK
- WILLIAMSBURG
- STRATUS
- SAGE
- OCEAN
- SNOW
- LIPSTICK

Width: 54"	YARD	10 YDS	35 YDS
	33.80	29.80	26.50

GUNSLINGER

SUITABLE APPLICATIONS

•Office •Commercial Seating •Residential •Marine •RV •Automotive

MANUFACTURED TO MEET THE FOLLOWING CODES:

- Motor Vehicle Safety Stnd #302
- California Tech Bulletin 117
- NFPA 260
- UFAC Class 1

FINISHES & TREATMENTS:

- Abrasion: Highly Durable ASTM D 4157 Exceeds 100,00 double rubs•
- PVC Free
- Face Content: 12% Polyester
- Backing Content: 43% Recycled Leather, 40% Polyester, 17% Cotton

embrace™
Recycled Leather

SPECIFICS:

- Width: 54"
- Weight: 20.3oz
- 35 yard roll

CLEANING

- *This product should be cleaned with mild soap and water.*
- *Do not use alcohol based cleaners!*

COFFEE
SADDLE
BLACK
RED

Width: 54"

YARD	10 YDS	30 YDS
37.80	33.30	29.50

OREGON TRAIL

SUITABLE APPLICATIONS

•Office •Commercial Seating •Residential •Marine •RV •Automotive

MANUFACTURED TO MEET THE FOLLOWING CODES:

- Motor Vehicle Safety Stnd 302
- California Tech Bulletin 117
- NFPA 260
- UFAC Class 1

FINISHES & TREATMENTS:

- Abrasion: Highly Durable ASTM D 4157 Exceeds 100,00 double rubs•
- PVC Free
- Face Content: 100% Polyurethane
- Backing Content: 43% Recycled Leather, 40% Polyester, 17% Cotton

embrace™
Recycled Leather

SPECIFICS:

- Width: 54"
- Weight: 20.3oz
- 35 yard roll

CLEANING

- *This product should be cleaned with mild soap and water.*
- *Do not use alcohol based cleaners!*

JAVA
PUTTY
BOURBON
SADDLE

Width: 54"

YARD	10 YDS	30 YDS
44.30	39.00	34.60

URBAN EXOTICS

Vinyl and Urethane faux animal skins

MANUFACTURED TO MEET THE FOLLOWING CODES:

- Varies per pattern

SUITABLE APPLICATIONS:

- Residential

SPECIFICS:

- Width: 54"
- Weight: varies per pattern
- 30 yard roll

PATTERNS

AZTEC	LAREDO	LIZARDO
OUTBACK	CROCK	BI-CROCK
RUSTICO	EMU	EVERGLADE

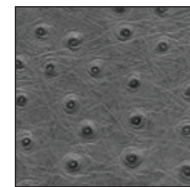

Width: 54"

YARD	10 YDS	30 YDS
41.70	37.10	32.90

RECAST

Recycled Leather - Urethane Surface

MANUFACTURED TO MEET THE FOLLOWING CODES:

- Motor Vehicle Safety Standard 302
- California Tech Bulletin 117 Section E
- UFAC: Class 1
- NFPA 260
- IMO A.652(16)8.2

FINISHES and TREATMENTS:

- Abrasion - heavy duty: Wyzenbeek
- 100,000 cycles #8 cotton duck
- Heat sealable
- Cold Crack -10 F
- Mildew resistant backing and face
- UV stabilized pigments: 40 indoor hour
- Anti-bacterial and anti-microbial: Pass*

SPECIFICS:

- Surface type: 100% PU
- Width: 54"
- Weight: 28.5 oz
- Contents: 60%PU
- 22% Fabric,
- 18% Leather
- Roll length: 30 yards
- Cleaning Code: W
- Origin:China

PATTERNS

JAMES	MAVERICK
TAOS	VENUS
TUSCANY	STARLITE

Width: 54"

YARD	10 YDS	30 YDS
36.70	32.70	29.00

The ReCast Collection is a group of unique, superior-quality products which are so leather-like, it looks like the real thing. Recycled leather is incorporated onto the back of 100% polyurethane, resulting in a composite product that looks, feels and even squeaks like genuine top grain leather.

COLORGUARD

MANUFACTURED TO MEET THE FOLLOWING CODES:

- Motor Vehicle Safety Standard 302
- California Tech Bulletin 117 Section E
- Class Ratings: ASTM D 3690 - Class A
- FAR 25.853B
- 100% Vinyl Face
- UFAC Fabric Class 1
- Port Authority of NY and NJ

FINISHES and TREATMENTS:

- Abrasion: Wyzenbeek heavy duty 400,000 cycles #8 cotton duck
- Heat sealable
- Cold Crack -20 F
- UV stabilized pigments: 650 hours minimum

SUITABLE APPLICATIONS:

- Marine
- Transportation
- Corporate
- Healthcare
- Hospitality

SPECIFICS:

- Width: 54"
- Weight: 36 ozs.
- 30 yard roll

Cleaning Instructions:

This product should be cleaned with mild soap and water.

Do not use alcohol based cleaners!

417918 SNOW	518765 BURGUNDY	520202 AMERICAN BEAUTY
517420 BLACK	518766 CADET	521374 MANZANITA
517423 GRAY	518767 CANDY APPLE	523027 VERY BERRY
517424 NEPTUNE	518768 COFFEE CREAM	523426 MARIGOLD
517701 SLATE	518769 COLONIAL BLUE	532613 DREAM
517730 SADDLE TAN	518770 CORDOVAN	532614 WHEAT
517908 NATURAL	518771 DEEP CLAY	532615 GRIS
517919 PURPLE IRIS	518772 EMERALD	532616 AQUA
517920 NAVY	518773 EVERGLADE	532617 CERULEAN
517921 NASTURIUM	518775 GRAPE	532618 GRASS
517922 FUDGE	518777 GREEN TEA	532619 MAGENTA
518386 VISCAYA PALM	518778 HARBOUR	533612 REFLECTION
518417 SPRUCE	518779 HUNTER GREEN	
518418 SEAFOAM	518780 LEAPFROG	
518419 SEAGRASS	518781 LITE GRAY	
518420 LIGHT TEAL	518784 MARINA	36373400—MOONGLOW
518421 JADE	518785 MIDNIGHT BLUE	36375400—CHINA-GREEN
518422 CHOCOLATE	518787 NEW BURGUNDY	36377400—IRIS
518423 CAMELBACK	518789 OTTER	36416000—CERISE
518424 BEIGE	518790 OUTBACK	43915400—FRONTIER
518634 PUMICE	518791 PERSIMMON	43916500—PHOENICIAN
518635 HORIZON BLUE	518792 PORT	47432900—BIG-KISS
518636 BUCKSUEDE	518794 RAIN TREE	47433600—FLAX
518647 COAL	518795 RED CENT	47520800—CANYON-ROSE
518703 BLUEJAY	518796 ROYAL BLUE	47521100—LODEN
518705 REGAL BLUE	518799 TEA LEAF	47521200—MIST
518760 ALLSPICE	518800 TOMATO	517566—DARK-NILE
518761 BERRY	518802 WHITE	525846—RAFFIA
518762 BLUE NILE	518804 WOOD VIOLET	BURNT-ORANGE
518763 BLUEBERRY	520053 NEW PURPLE	ROSEWOOD



Width: 54"

YARD
45.00

10 YDS
39.20

30 YDS
34.90



GRAND SIERRA

MANUFACTURED TO MEET THE FOLLOWING CODES:

- Motor Vehicle Safety Standard 302
- California Tech Bulletin 117 Section E
- Boston Fire Department 1X-1
- FAR 25.853B
- 100% Vinyl Face
- UFAC Fabric Class 1
- Port Authority of NY and NJ

FINISHES and TREATMENTS:

- Abrasion - heavy duty: Wyzenbeek 1,000,000 cycles #8 cotton duck
- Heat sealable • Cold Crack -20 F
- UV stabilized pigments: 650 hours minimum

SUITABLE APPLICATIONS:

- Marine
- RV • Auto
- Corporate • Residential
- Healthcare • Hospitality

SPECIFICS:

- Width: 54"
- Weight: 36 ozs.
- 30 yard roll

517702 OXBLOOD	518382 FIRE RED	41552300—PEACH
517705 GRAY	518711 CRANBERRY	41552700—TROPIC
517706 WHEAT	518728 BURRO	41552800—WHITE HONEY
517707 CHOCOLATE	518729 SPICE	46847300—AGATE
517708 AZURE	518756 CHESTNUT	46847500—BISCUIT
517709 CROCUS	518881 HUNTER	46847700—CLOUD
517734 TEAL	519000 CHARCOAL	46847800—CLOVE
517916 SUEDE	519029 NAVY	46848000—IVY
517917 BLACK	519030 ALMOND	46848100—PIMENTO
518375 BAMBOO	519251 COLONIAL BLUE	HONEY
518379 SHADOW	521544 SEAFOAM	
518380 PLUM	522172 BOMBAY	
	524452 SLATE	



Width: 54"

YARD
46.80

10 YDS
40.80

30 YDS
36.40



HARMONY

MANUFACTURED TO MEET THE FOLLOWING CODES:

- Motor Vehicle Safety Standard 302
- California Tech Bulletin 117 Section E
- Boston Fire Department 1X-1
- FAR 25.853B
- 100% Vinyl Face
- UFAC Fabric Class 1

FINISHES and TREATMENTS:

- Abrasion - heavy duty: Wyzenbeek 400,000 cycles #8 cotton duck
- Heat sealable • Cold Crack -20 F
- UV stabilized pigments: 72 hours minimum

SUITABLE APPLICATIONS:

- Corporate
- Healthcare
- Hospitality

SPECIFICS:

- Width: 54"
- Weight: 36 ozs.
- 30 yard roll

43632600—ADOBE GLOW	43633500—NAVY
49083500—BLUE SPRUCE	49083400—OLIVE TREE
49084000—COFFEE BEAN	49083700—PEAR
43633000—DESERT-TAN	49083600—RED EARTH
49084100—HENNA	43633900—SEAFOAM
49084200—INCA	43634000—SERENITY-ROSE
43633200—IVY-GREEN	49083800—SISAL
43633400—LUXOR-BLUE	



Width: 54"

YARD
49.60

10 YDS
43.10

30 YDS
38.40



LEVANTE

PreFixx Boltaflex

MANUFACTURED TO MEET THE FOLLOWING CODES:

- Motor Vehicle Safety Standard 302
- California Tech Bulletin 117 Section E

FINISHES and TREATMENTS:

- Abrasion: 6000 stainless steel screen wire
- Heat sealable: di-electrically and RF sealable
- Cold Crack -20 F • QUV: 40 hours
- Mildew resistant: ASTM - G21
- Anti-fog: SAE J1756

SUITABLE APPLICATIONS:

- Residential
- General seating
- General sewn products
- Marine • Auto • RV

SPECIFICS:

- Width: 54"
- Weight: 22 ozs./ In. yd.
- 50 yard roll

- 521817 BLACK
- 522769 BURGUNDY
- 522770 HUNTER GREEN
- 522771 SOFT WHITE
- 522772 TEAL
- 522773 AGATE BLUE
- 522774 BURNT ROSE
- 522775 BUFF
- 522776 HAZE GRAY
- 522777 FLINT GRAY
- 522778 MUSHROOM
- 522779 BROWN SUGAR
- 522780 DUTCH BLUE
- 522781 CHOCOLATE
- 522782 DUNE

- 31691600—RUSSET
- AQUA SPRAY
- ASH ROSE
- BRITE YELLOW
- GRAY JADE
- ROMAN TAN
- SADDLE
- SLATE

Width: 54"	YARD	10 YDS	50 YDS
	30.20	26.30	23.40

PREFIXX®

The first protective finish that starts where other finishes finish!



Protective finish:

The PreFixx® protective finish has been designed to be cleaned easily, over and over, without showing signs of wear. With PreFixx® protection, it is possible to remove stains that could never be removed before. With test-proven stain removal and cleanability, plus superior abrasion resistance, PreFixx protects you from high maintenance costs and from frequent upholstery replacement costs.

PreFixx PROTECTIVE FINISH GOES BEYOND PREVIOUS PROTECTION

- PERFORMANCE** *State-of-the-art resistance to staining, abrasion, scuffing, burnishing and blocking; demonstrated in repeated laboratory tests.*
- DURABILITY** *Resists stain penetration of the vinyl for unique, long-term protection never before possible. The superior stain resistance and improved wear properties help keep PreFixx®-protected vinyl looking new far longer than other vinyl upholstery.*
- EASY MAINTENANCE** *Common stains like dirt and smudges simply wipe off. More difficult stains, such as ballpoint ink can be cleaned with active solvents such as nail polish remover (acetone/water) without damaging the PreFixx® finish when following the recommended cleaning instructions.*

PREFIXX PROTECTIVE FINISH

- **Outstanding stain resistance and cleanability.** Most stains wash off easily with mild cleaners, but active solvents may be used to remove difficult stains.
- **Abrasion resistance.** Wyzenbeek wire screen abrasion tests performed by OMNOVA Solutions Inc. show 10 to 12 times better abrasion resistance than a similar product coated with a clear vinyl finish. These tests show that vinyl upholstery with a clear vinyl finish withstands about 6,000 test cycles; while vinyl with PreFixx® withstands in excess of 100,000 cycles.
- **Resistant to common scuffing and burnishing.**
- **Eliminates blocking and resists premature aging.**

DAY-TO-DAY SOIL: Remove ordinary dirt and smudges with a mild soap and warm water solution. Dry with a soft, lint-free cloth or towel. For more difficult stains, use of stronger detergent is recommended, however, follow the detergent manufacturer's instructions closely.

SPECIAL CLEANING PROBLEMS: The following steps are recommended to clean stains on PreFixx-protected vinyl upholstery. Many difficult stains can be removed when these cleaning agents are used in the following order.

STEP 1 CLEANERS:

Nonabrasive household cleaners to be used with a soft cloth or damp sponge:

- Formula 409® All-Purpose Spray Cleaner
- Fantastik® Spray Cleaner
- Other similar household cleaners and bleaches.
- Rinse cleaned area with fresh water and dry with a clean cloth.

STEP 2 CLEANERS:

Solvent-type cleaner to be liberally applied with a soft or damp sponge.

- Rubbing alcohol (isopropyl alcohol)
- Lighter fluid (naptha)
- Rinse cleaned area with fresh water and dry with a clean cloth.

STEP 3 CLEANERS:

Strong, active solvent cleaners such as nail polish remover (acetone/water)

- To be applied with a soft cloth or damp sponge. Stain should be removed with less than six (6) rubs (if stain persists after six rubs, stain has set and it is unlikely that it can be removed.)
- Rinse cleaned area with fresh water and dry with a clean cloth.

Recommended cleaning solutions for PreFixx protected vinyl

STAINING AGENT	TYPE OF CLEANER
Spray Paint	1-2-3
Permanent Felt Tip Marker Pen	1-2-3
Ballpoint Pen	1-2-3
Lipstick	1-2-3
Yellow Mustard	1-2-3
Nicotine	1-2
Grease	1-2
Crayons	1-2
Eye Shadow	1-2
Betadine	1
Coffee	1
Tea	1
Hair Oil Tonic	1
Blood	1
Urine	1
Grape Juice	1
Olive Oil	1
Motor Oil	1
Chocolate	1
Ketchup	1
Baby Oil	1

+ Although vinyls protected with PreFixx® are resistant to most common stains, some fabric dyes have the ability to create a permanent stain. To minimize any problems from these and others stains, it is recommended that as soon as they are noticed, all stains should be cleaned, making sure the recommended cleaning steps are followed in order.
* CAUTION: these solvents are highly flammable. Exercise proper care in cleaning and notify personnel in area of danger. Wear rubber gloves during all cleaning activity. Use caution in cleaning around buttons, stitching, wooden, and other decorative trim, since these solvents could seriously damage such areas.

CAPITANO



MANUFACTURED TO MEET THE FOLLOWING CODES:

- Motor Vehicle Safety Standard 302
- California Tech Bulletin 117 Section E

FINISHES and TREATMENTS:

- Abrasion: 6000 stainless steel screen wire
- Heat embossable only
- Cold Crack -20 F • QUV: 650 hours
- Mildew resistant: ASTM - G21
- Anti-fog: SAE J1756

SUITABLE APPLICATIONS:

- Residential
- General seating
- General sewn products
- Marine • Auto • RV

SPECIFICS:

- Width: 54"
- Weight: 29 ozs./ In. yd.
- 30 yard roll

	YARD	15 YDS	30 YDS
Width: 54"	26.00	22.60	20.80

513658	CLOUD/MYSTIC WHITE	513938	SANDRIFT
513659	RIVERA/PARADOX BLUE	513953	DAREDEVIL/CLASSIC RED
513660	LEMON DROP/SOLAR YELLOW	514006	CONCH SHELL/OFF WHITE
513783	GRAY LITE	514009	GALAPAGOS/GLEN GREEN
513832	CYBERSPACE/SLATE BLACK	514019	VEDRA
513846	BLUE CHIP/OFFSHORE BLUE	514287	SANDSHELL/PUTTY
513887	TECHNO GRAY/GRAY MATTER	519970	BEACH WHITE/CRYSTAL WHITE
513900	ECLIPSE/OLD NAVY		
513903	SAND DOLLAR/MUSHROOM		
513905	VANILLA		
513936	RED CHILE		
513937	TOTALLY TAN/SAHARA		

MARINER



MANUFACTURED TO MEET THE FOLLOWING CODES:

- Motor Vehicle Safety Standard 302
- California Tech Bulletin 117 Section E

FINISHES and TREATMENTS:

- Abrasion: heavy duty Wyzenbeek
- Cold Crack -20 F • QUV: 650 hours
- Mildew resistant: ASTM - G21
- Heat sealable
- Anti-fog

SUITABLE APPLICATIONS:

- General seating
- General sewn products
- Marine • Auto • RV

SPECIFICS:

- Width: 54"
- Weight: 30 ozs./ In. yd.
- 30 yard roll

	YARD	15 YDS	30 YDS
Width: 54"	28.50	24.80	22.10

40229500	BUCKSKIN	48022600	LIME GREEN
	BRIGHT RUBY	42269700	LITE GRAY
42267500	BRITE NAVY	42270100	LOLLIPOP
48185900	CHOCOLATE	42270400	MOON ROCK
42268000	CHROME YELLOW	42270600	MUSHROOM
42268100	CINDER GRAY	42270500	MYSTIC WHITE
42268600	DEEP BLUE	42270700	NAVY
42268800	GRAY LIGHT	42270800	OFF WHITE
42269500	IVORY	48161800	PACIFIC OYSTER
42867100	LATTE	42271200	PUTTY

NEW SOHO

MANUFACTURED TO MEET THE FOLLOWING CODES:

- Motor Vehicle Safety Standard 302
- California Tech Bulletin 117 Section E

FINISHES and TREATMENTS:

- Abrasion: 6000 stainless steel screen wire
- Heat sealable: di-electrically and RF sealable
- Cold Crack -20 F • QUV: 650 hours
- Mildew resistant: ASTM - G21
- Anti-fog: SAE J1756

SUITABLE APPLICATIONS:

- Residential
- General seating
- General sewn products
- Marine • Auto • RV

SPECIFICS:

- Width: 54"
- Weight: 28/29 ozs./In.yd.
- 40 yard roll

	YARD	15 YDS	30 YDS
Width: 54"	21.70	18.90	17.20

VNS-001	AMERICAN BEAUTY	VNS-021	IVORY
VNS-002	AQUA GREEN	VNS-023	KELLY GREEN
VNS-003	AVOCADO	VNS-025	MUSHROOM
VNS-004	BLACK WALNUT	VNS-027	PEARL
VNS-005	BLUE RIDGE	VNS-028	PLUM
VNS-006	BRIGHT VNS-YELLOW	VNS-029	ROYAL BLUE
VNS-007	BURGUNDY	VNS-030	SAND
VNS-008	CHOCOLATE CHIP	VNS-031	SILVER GREY
VNS-009	CLARET	VNS-032	SILVER SURF
VNS-010	CONCORD	VNS-033	SKY BLUE
VNS-012	DARK CHERRY	VNS-034	SUPER WHITE
VNS-013	EBONY	VNS-035	TAN
VNS-014	EXPRESSO	VNS-037	TEA ROSE
VNS-016	FOREST	VNS-038	TIGER LILLY
VNS-017	GEORGIA CLAY	VNS-040	YELLOW GOLD
VNS-018	GRAPHITE	VNS-041	YEW GREEN
VNS-020	INDIGO		

ALLURE

MANUFACTURED TO MEET THE FOLLOWING CODES:

- Motor Vehicle Safety Stnd 302
- California Tech Bulletin 117
- BIFMA Class 1

FINISHES and TREATMENTS:

- Abrasion - heavy duty (Wyzenbeek)
- Static dissipative
- Cold Crack -20
- Sulfide and oil resistant
- UV stabilized pigments
- Mildew resistant
- ASTM 1428- Pink Stain Test

SPECIFICS:

- Width: 54"
- Weight: 26 oz.
- 35 yard roll

SUITABLE APPLICATIONS:

- RV
- Marine
- Automotive
- Residential
- Office / commercial seating

	YARD	10 YDS	35 YDS
Width: 54"	45.00	40.20	35.40



AL-34	SAGE	AL-42	NOCTURNAL
AL-35	BAYSIDE	AL-43	RUBY
AL-36	SOAP STONE	AL-44	STRAWBERRY
AL-37	CLAY DUST	AL-45	TONIC
AL-38	CRANBERRY	AL-46	TRUE BLUE
AL-39	HARMONY	AL-47	WINTER WHITE
AL-40	MALT	AL-48	AUTUMN GLADE
AL-41	MILL GREEN		

CHAMEA II

MANUFACTURED TO MEET THE FOLLOWING CODES:

- Motor Vehicle Safety Std #302
- California Tech Bulletin 117
- BIFMA Class 1

FINISHES & TREATMENTS:

- Abrasion - heavy duty (Wyzenbeek)
- Static dissipative
- Cold Crack -20
- Sulfide and oil resistant
- UV stabilized pigments
- Mildew resistant
- ASTM E 1428- Pink Stain Test

SPECIFICS:

- Width: 54"
- Weight: 26 oz.
- 35 yard roll

SUITABLE APPLICATIONS:

- Office/commercial seating
- Residential
- Marine • RV
- Automotive

- CY-01 GRAPHITE GREY
- CY-02 STARDUST
- CY-03 RED
- CY-04 BEACH
- CY-05 SUNLIGHT
- CY-06 STONE
- CY-07 BUTTER
- CY-08 BAJA BROWN
- CY-09 WATER
- CY-10 PALM
- CY-11 OLIVE
- CY-12 SAND



- CY-13 CHAPS
- CY-14 MAHOGANY
- CY-15 BUFF
- CY-16 SPRUCE
- CY-17 NAVY
- CY-18 BLACK
- CY-19 ANTELOPE
- CY-20 SOFT WHITE
- CY-21 DARK PEWTER

- CY-22 LIGHT GRAY
- CY-23 AMBER
- CY-24 EDEN
- CY-25 FIRST LIGHT
- CY-26 HONESTY
- CY-27 MARMALADE
- CY-28 MELON
- CY-29 OCEAN
- CY-30 CYPRUS
- CY-31 ROSA
- CY-32 SEA GLASS
- CY-33 WOOD VIOLET
- CY-34 SPICE
- CY-35 VALLEY

Width: 54"

YARD 45.00 10 YDS 40.20 35 YDS 35.40

DIMENSIONS

MANUFACTURED TO MEET THE FOLLOWING CODES:

- UFAC-Class 1
- California Tech Bulletin 117 Section E
- NFPA 260
- Motor Vehicle Safety Standard 302

SPECIFICS:

- Width: 54"
- Weight: 25oz. lineal yard
- Thickness: 42 mil
- Yards/Roll: 30 (+/- 2yds)

Width: 54"

FINISHES & TREATMENTS:

- Abrasion Resistance; Protected with special finish to conform to Wyzenbeski CFFA-1 Fed Standard 191A Method 5304 - 100,000 double rubs MF-MH BN 8.2
- UV light Resistance; protected with special agents with over 1000 hours ultra violet resistance formulated with UV light resistant pigments
- Mildew Resistance; back and face protected to conform with ASTM G21

APPLICATIONS

- Contract interiors
- Office
- Restaurants
- Hotel / Motel
- Nursing Homes
- Hospitals
- Marine • RV • Auto
- Residential
- Interior or Exterior

COLORS:

- AEGEAN
- ALMOND
- BALSAMIC
- BUFF
- CHAMOIS
- CHARCOAL
- DUSTY BLUE
- EARLY SPRING
- EBONY
- FRESH LEAF
- LILAC DUST
- MERLOT
- MIDNIGHT
- MILKWEED
- PAPRIKA
- PAPYRUS
- PURPLE ORCHID
- STORM CLOUD
- SWEET CHERRY



with NANOCIDE™ Antimicrobial!
99.9% of resistant Staphylococcus germs that come in contact with it are killed within 30 minutes!

YARD 51.10 10YDS 46.10 30 YDS 39.60

ALLANTE

MANUFACTURED TO MEET THE FOLLOWING CODES:

- Motor Vehicle Safety Standard 302
- California Tech Bulletin 117, Sec. E
- BIFMA Class A
- UFAC Class 1
- Cold Crack: -25°F

FINISHES and TREATMENTS:

- Abrasion resistance: No significant wear after 100,000 double rubs with #8 cotton duck using the Wyzenbeek test method.
- Mildew resistant
- 1000 hours Weathermeter

SPECIFICS:

- Width: 54"
- Weight: 29 ozs.
- Yards Per Roll: 40

SUITABLE APPLICATIONS

- Automotive seating and trim
- Executive seating
- Hotel/motel room seating
- Foyer and lounge seating
- Work station seating
- RV seating and trim
- Home office seating
- General office seating
- Conference room seating



- AL-802 BLACK
- AL-804 CHARCOAL
- AL-806 ASH
- AL-808 GRAY
- AL-809 NU-SHALE
- AL-810 WHITE
- AL-814 PINE MOUNTAIN
- AL-816 CADET
- AL-818 GALAXY
- AL-820 DARK BLUE
- AL-821 REGIMENTAL BLUE
- AL-822 ROYAL BLUE
- AL-824 NU-ANTELOPE
- AL-825 MED. PRAIRIE TAN
- AL-827 SEA OYSTER
- AL-828 ELEPHANT
- AL-830 PURPLE GRAY
- AL-832 BURGUNDY

- AL-835 DARK PEWTER
- AL-836 WINE
- AL-838 CINNAMON
- AL-840 ESPRESSO
- AL-844 CREAM
- AL-846 BISQUE
- AL-848 LIGHT PLUM
- AL-854 LIGHT PARCHMENT
- AL-856 PEARL GRAY
- AL-860 BEECHWOOD
- AL-862 LIGHT NEUTRAL
- AL-864 LIGHT SAND
- AL-866 LIGHT MOCHA
- AL-868 TEAK
- AL-870 MEDIUM GRAY
- AL-872 MEDIUM NEUTRAL
- AL-874 LT. SANDALWOOD
- AL-876 MEDIUM BEIGE

- AL-977 NU-RED
- AL-879 GOLDEN TAN
- AL-880 SUNSHINE
- AL-882 CELADON
- AL-890 TUNDRA
- AL-894 MEADOW
- AL-895 HIDEAWAY
- AL-896 SEA CRUISE
- AL-897 REEF
- AL-898 PARROT
- AL-899 KHAKI
- AL-900 TUMBLEWEED
- AL-901 CAYENNE
- AL-902 BUTTERSCOTCH
- AL-903 TWINE
- AL-904 MANGO

CARE AND CLEANING INSTRUCTIONS

It is recommended that each stain is cleaned in a stepwise manner using the sequence below.

- Step 1: Regular cleaning dirt & grime: Use mild soap and water, then fresh water rinse. Cleaning frequency depends on use. Weekly cleaning is recommended.
- Step 2: Stubborn stains (crayon, eye shadow, chocolate, blood): wipe using a soft cloth or soft brush. Use detergent cleaners such as Formula 409® or Fantastik®. Rinse with clean water and wipe dry.

Width: 54"

YARD 40.70 10 YDS 36.60 35 YDS 34.40

ALL SPORT

CHARACTERISTICS:

- 360 Degree, 4 way stretch
- -60° F Cold Crack
- Superior tailorability
- High-Tac Black has a specially formulated non-slip finish

SPECIFICATIONS:

- >100% stretch in both directions (MI-TLWI-443)
- Nominal total thickness: .0048 inches (48+/- 5 mils)
- Standard weight: 36.00 +/- 2.25 ounces per linear yard
- Cold resistance: passes 60° F test method Federal Standard 191A 5874
- Weather Resistance: 1000 hours
ASTM G135-00a Cycle 1 Formerly (G23-99)
- Abrasion Resistance: no significant wear after 30,000 double rubs
- Mildew resistant

SPECIFICS:

- Width: 54"
- Weight: 29oz
- Yards Per Roll: 40

FLAME RESISTANCE: MANUFACTURED TO MEET THE FOLLOWING CODES:

- FMVSS-302
- California Technical Bulletin 117, Section E
- BIFMA Class A
- UFAC Class 1

** This term and all corresponding data refer to typical performance in the specific test indicated and should not be construed to imply the behavior of this or any other material under actual fire conditions.*

CARE AND CLEANING INSTRUCTIONS:

- **Step 1:** Regular cleaning (dirt and grime). Use mild soap and water, then fresh water rinse. Cleaning frequency depends on use. As a minimum, please clean weekly.
- **Step 2:** Stubborn stains (crayon, eye shadow, chocolate, blood); wipe using a soft cloth or soft brush. Use detergent cleaners such as Formula 409[®] or Fantastik[™]. Rinse with clean water and wipe dry.

**4-way Stretch!
-60°F Cold Crack!**

Morbern

RECOMMENDED APPLICATIONS



- All terrain vehicle
- Snowmobile
- Motorcycle
- Marine
- Watercraft
- Ski lift chairs
- Automotive
- Tractor seating
- Golf cart seating
- Extreme weather applications



AS-109 BRIGHT VIOLET



AS-100 BLACK



AS-102 CHALK



AS-104 BRIGHT RED



AS-106 ROYAL BLUE

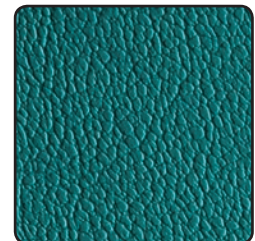

AS-108 MARINE GRN.



AS-101 HI-TAC BLACK



AS-103 NU YELLOW



AS-105 SILVER MET.

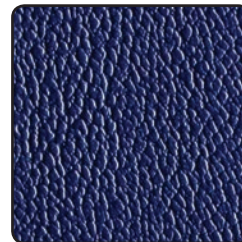

AS-107 ELEC. BLUE



AS-110 AZTEC RED

Width: 54"

YARD
61.60

10 YDS
55.50

40 YDS
51.20

XTREME SEATING

SUGGESTED APPLICATIONS

Motorcycle, ATV, Jetski, Bicycle, Automotive, Marine, General Upholstery

Oil and Sulfide Resistant

MEETS FLAMMABILITY REQUIREMENTS

- Motor Vehicle Safety Standard 302
- California Technical Bulletin 117 Section E

CLEANING:

- This product should be cleaned with mild soap and water.

4 Way Stretch

Non Slip

Multi Stretch

ENDURATEX™

We cover the world.

with PRODURATECT™ A

	RAPPER	RAPPER EXTREME	SLIPSTOP
Width	54"	54"	54"
Roll Size	30 Yds	30 Yds	40 Yds
Nominal Weight Per LY	30 oz	29 oz	28 oz
Thickness	.90 mm	1.31 mm	.80 mm
Backing	Nylon	Nylon	Poly/Rayon
Cold Crack	-10°F	-40°F	-30°F
UV Resistant ASTM G53	500 Hrs	500 Hrs	500 Hrs
Oil & Sulfide Resistant	Yes	Yes	Yes
Abrasion Wyzenbeek		100,000	



4 WAY STRETCH

SLIP STOP

MULTI STRETCH

	TYPE	YD/RL	YARD	10 YD	ROLL
Rapper	4 Way Stretch	30	43.20	39.00	34.30
Rapper Extreme	Multi Stretch	30	53.70	48.50	42.70
Slip Stop	Anti Slip Finish	40	36.30	32.70	28.90

KODIAK II BLACK

PREMIUM VINYL COLLECTION with PRODURATECT™ M

MANUFACTURED TO MEET THE FOLLOWING CODES:

- Motor Vehicle Safety Standard 302
- California Tech Bulletin 117
- Class ratings: ASTM D 3690 - Class A

FINISHES and TREATMENTS:

- Abrasion - heavy duty
- Heat sealable • Cold Crack -40 F
- Mildew resistant backing and face
- UV stabilized pigments: 300 hours minimum
- Anti-bacterial and anti-microbial
- Oil and sulfide resistant

SUITABLE APPLICATIONS:

- Residential
- Lounge seating
- Spas / Massage tables
- Conference room • Office
- Auto • Marine • RV

SPECIFICS:

- Width: 61"
- Weight: 50 ozs.
- Thickness: 1.50 mm
- 20 yard roll

Cleaning Instructions:

- This product should be cleaned with mild soap and water.
- Do not use alcohol based cleaners!

ENDURATEX™
We cover the world.



KOD-2601 BLACK

Width: 61"

YARD
39.50

10 YDS
36.50

30 YDS
33.50

Q1
BACKING

E-Z VINYL

CHARACTERISTICS:

- Formaldehyde Free
- -10° F Cold Crack
- Acrylic Topcoat
- No Heavy Metals

SPECIFICATIONS:

- Superior Abrasion: 50,000 cycles/Wyzenbeek
- Exclusively Interiors
- *Wallaby Marine White - Exterior Approved

SPECIFICS:

- Width: 54"
- Weight: 25oz
- Yards Per Roll: 30

FLAME RESISTANCE:

MANUFACTURED TO MEET

THE FOLLOWING CODES:

- California T.B. 117-2013
- FMVSS 302
- NFPA 260- Cover Fabric – Class I
- UFAC Fabric – Class I
- IMO FTP 2010 Code MSC.307(88) Part 8: 3.1 & 3.2



WALLABY

- 5801 IMPERIAL BLUE
- 5802 STEEL BLUE
- 5803 TURQUOISE
- 5804 ROYAL
- 5805 FOREST
- 5806 LIME
- 5807 OLIVE
- 5808 MOSS
- 5809 NEUTRAL
- 5810 TAUPE
- 5811 TAN
- 5812 BROWN
- 5813 ESPRESSO
- 5814 TERRA COTTA
- 5815 CLAY
- 5816 MAROON
- 5817 RUBY
- 5818 POPPY
- 5819 MARINE WHITE*
- 5820 GRAY
- 5821 GUNMETAL
- 5822 IRON
- 5823 BLACK

OXEN

- 5830 MAROON
- 5831 BROWN
- 5832 BLACK

MONTICELLO

- 5833 MED. GRAY

MADRID

- 5834 BLACK

CORINTHIAN

- 5835 BLACK

HEIDI

- 5836 BLACK

ELK

- 5837 BLACK

SIERRA

- 5824 TORCH RED
- 5825 DARK MAPLE
- 5826 BROWN
- 5827 BLACK
- 5828 ROYAL
- 5829 OFF WHITE



BLACKS
COLORS
MARINE WHITE

YARD	10 YDS	30 YDS
15.90	13.90	11.50
18.30	15.60	13.60
20.10	17.10	15.10

PROMOTIONAL BLACK and WHITES

GENERAL CHARACTERISTICS:

- Practical
- Durable
- Easily cleaned
- 100% vinyl surface
- 100% polyester substrate

SPECIFICS:

- Width: 54"
- Weight: 26 ozs.
- 40 yard roll

SUITABLE APPLICATIONS:

- Office
- Residential
- Automotive



- 4901 OXEN BLACK
- 4902 SIERRA BLACK
- 4903 WALLABY BLACK
- 4904 MADRID BLACK
- 4905 RAWHIDE BLACK
- 4906 MADRID WHITE
- 4907 WALLABY WHITE
- 4908 SIERRA WHITE

Width: 54"	YARD	10 YDS	40 YDS
	21.70	18.30	15.80

PAUL BUNYON HEAVY DUTY AUTO VINYLs BLACK

MANUFACTURED TO MEET

THE FOLLOWING CODES:

- Motor Vehicle Safety Standard 302
- California Tech Bulletin 117

SPECIFICS:

- Width: 54"
- Weight: 38 oz.
- 20 yard roll
- Cold Crack -30 F
- 100% virgin vinyl
- UV stabilized pigments (300/hrs)

Cleaning Instructions:

- This product should be cleaned with mild soap and water.
- Do not use alcohol based cleaners!



- 0902 MADRID BLACK
- 0903 OXEN BLACK
- 0904 RAWHIDE BLACK
- 0905 SIERRA BLACK
- 0906 WALLABY BLACK

Width: 54"	YARD	10 YDS	30 YDS
	36.00	32.40	29.00

SOFTSIDE BLACKS

MANUFACTURED TO MEET THE FOLLOWING CODES:

- Motor Vehicle Safety Standard 302
- California Tech Bulletin 117

FINISHES and TREATMENTS:

- Abrasion - heavy duty: Wyzenbeek/CFFA-1
- Heat sealable
- Cold Crack -10 F
- Light fastness: 300 hours minimum
- UV stabilized pigments

SUITABLE APPLICATIONS:

- Office
- Residential
- Automotive

SPECIFICS:

- Width: 54"
- Weight: 29 ozs.
- 30 yard roll



HIGH-LOFT²
BACKING

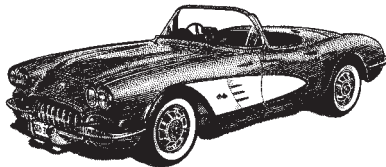

Width: 54"	YARD 33.30	10 YDS 30.00	30 YDS 27.50
------------	----------------------	------------------------	------------------------

Apex	APX-2548	Raven
Aries	ARI-1606	Ebony
Carbon Fiber	CAR-1100	Black
Gemini	GEM-2574	Raven
G-Grain	GGR-7227	Ebony
Grand Prix	GPX-9467	Black
Heidi Soft	HDI-6507	Ebony
Madrid Soft	MAS-9830	Black
Milled Pebble	MIL-7397	Ebony
Montana Soft	MOS-9378	Black
Monticello Soft	MOT-9810	Black
Nuance	NUA-2457	Ebony
Orion	ORI-1612	Ebony
Oxen Soft	OXS-9840	Black
Pegasus	PEG-1618	Ebony
Polaris	POL-1624	Ebony
Ruffino Soft	RUS-9850	Black
Sierra Soft	SIS-9562	Black
Wallaby Soft	WAS-9860	Black

SOFTSIDE
THE AUTOMOTIVE
COLLECTION

SOFTSIDE
THE FURNITURE
COLLECTION

SOFTSIDE
THE MARINE
COLLECTION

ENDURATEX BLACKS

ENDURATEX™  **FORBID.**
We cover the world.

PATTERN	CODE	DESCRIPTION	F*	YARD	10 YDS	ROLL	PATTERN	CODE	DESCRIPTION	F*	YARD	10 YDS	ROLL
ARMADA	ARM-126	TSUNAMI		29.00	24.50	21.10	LONGITUDE	LNG-167A	EBONY		36.80	31.10	26.80
ASPIRATIONS	ASP-200	BLACK BEAN		42.40	35.80	30.80	LUNAR	LUN-400	BLACK		46.20	38.90	33.50
BERWICK TWEED	BRW-600	CARBON FOOTPRINT		49.70	41.90	36.10	LUXOR	LUX-8802	BLACK	Y	29.80	26.80	24.00
BRITISH STERLING	BRS-200	GRANITE		45.40	38.30	33.00	MADRID	MDS-2295	BLACK	Y	29.80	26.80	24.00
BRUSHED ALUMINUM	ALU-100	BLACK		39.90	35.90	32.10	MERCEDES	CLS-7315	ANTHRACITE	Y	29.80	26.80	24.00
CARBON FIBER	CAR-100	CLASSIC BLACK		38.50	34.60	31.00	MILLED PEBBLE	MPS-7397	EBONY	Y	29.80	26.80	24.00
CHAIN MAILLE	CHM-221	BLACK KNIGHT	Y	57.10	51.40	46.00	MILLED PEBBLE	MPS-7400	MIDNIGHT BLACK	Y	29.80	26.80	24.00
COASTAL RANCH	COA-4197	EBONY	Y	40.60	36.60	32.70	MONTANA	ESM-6112	RAVEN	Y	29.80	26.80	24.00
CORINTHIAN	COS-3722	BLACK	Y	32.00	28.80	25.80	MONTICELLO	MTS-7286	BLACK	Y	29.80	26.80	24.00
CRIANZA	CRI-300	BLACK BEAUTY		77.10	65.00	56.00	OSSIE	OSS-500	EBONY		42.20	38.00	34.00
DOESKIN	DOS-4849	BLACK	Y	29.80	26.80	24.00	OXEN	OXS-4560	OXEN BLACK	Y	29.80	26.80	24.00
ECLIPSE	ECL-001	INFINITY BLACK	Y	35.50	32.00	28.60	PAUL BUNYON	0902	MADRID BLACK		36.00	32.40	29.00
EL CAPITAN	ELC-3100	COLONIAL BLACK		45.80	41.20	36.90	PAUL BUNYON	0904	SIERRA BLACK		36.00	32.40	29.00
EL CAPITAN	ELC-3101	MADRID BLACK		45.80	41.20	36.90	PAUL BUNYON	0906	WALLABY BLACK		36.00	32.40	29.00
G GRAIN	GGG-7170	MIDNIGHT BLACK	Y	29.80	26.80	24.00	PRIZM	PRZ-002	BLACK	Y	42.10	37.90	33.90
G GRAIN	GGG-7227	EBONY	Y	29.80	26.80	24.00	SIERRA	ESS-958	BLACK	Y	29.80	26.80	24.00
G GRAIN	GGG-7391	BLACK INK	Y	29.80	26.80	24.00	SIERRA	ESS-958G	BLACK	Y	29.80	26.80	24.00
GRAN RESERVA	GRS-2650	BLACK BEAUTY		58.40	52.60	47.00	SOHO	7525	CHARCOAL BLACK		36.60	30.90	26.60
GRAND VISTA	GRV-003	BLACK	Y	43.80	39.40	35.30	TRADEWINDS PLUS	TRA-6604	BLACK SEA	Y	35.00	31.50	28.20
HAMPTON	HPT-6508	EBONY	Y	29.80	26.80	24.00	VAQUERO	VAQ-1036	NIGHT RIDER		51.70	46.80	42.50
HAMPTON PERF	HAP-6508	EBONY	Y	37.50	33.70	30.20	VERONA	7482	CHARCOAL BLACK		36.60	30.90	26.60
HEIDI	HES-9840	BLACK	Y	36.70	33.00	29.50	WALLABY	WAS-5004	BLACK	Y	29.80	26.80	24.00
HONDA	HON-537	GRAPHITE BLACK	Y	29.80	26.80	24.00	WINDSONG 2	WIS-742	HURRICANE BLACK	Y	35.00	31.50	28.20
INDEPENDENCE 2	IND-8540	BLACK	Y	32.80	29.50	26.40							
JETSTREAM	JET-019	BLACK PEARL		41.00	36.90	33.00							

F* Forbid Stain Resistant Topcoat

SYMPHONY CLASSIC

RESILIENCE™

THE FAUX LEATHER THAT BUILDS LUXURY INTO PERFORMANCE™

MANUFACTURED TO MEET THE FOLLOWING CODES:

- California Tech Bulletin 117-2013 Section E
- NFPA 260
- ASTM E-84 (Adhered and Unadhered): Class 1 or A
- UFAC Class 1
- Motor Vehicle Safety Standard 302
- IMO 2010 FTP Code, Part 8

FINISHES and TREATMENTS:

- Abrasion - Heavy Duty: Wyzenbeek 500,000 cycles
- Cold Crack -20 CFPA 6a-2010
- Mildew resistance: ASTM G21-13
- Anti-Bacterial pass AATCC 147-2011
- Anti-Microbial pass AATCC 147-2011
- Color Fastness to Light: 1,000 Hours AATCC 16.3-2014 Option 3
- Color Fastness to Crocking 5.0 Wet 5.0 Dry AATCC 8-2016
- UV Resistance 1,000 Hours ASTM G154-12a
- Sulfide stain resistant
- Bleach Resistance: 10% Dilution AATCC 107-2013

SUITABLE APPLICATIONS:

- Hospitality
- Healthcare
- Residential
- Automotive
- RV
- Contract
- Education
- Marine

REDUCED ENVIRONMENTAL IMPACT:

- Phthalate Free
- Lead Free
- BPA Free/TRIS Free/Formaldehyde Free
- Does Not Contain Conflict Minerals

SPECIFICS:

- Width: 54"
- Weight: 29 ozs.
- 30 Yard Rolls
- Surface: 100% PVC(Phthalate Free)
- Backing: 100% Polyester Brushed Knit
- Stain Resistance: Resilience™

The use of commercial vinyl conditioners and protectants is not recommended.

PROP 65 WARNING: This product may contain a chemical known to the State of California to cause cancer and birth defects or other reproductive harm.



Width: 54"

YARD
46.60

10 YDS
42.80

30 YDS
39.10

Superior Stain Resistance
Soft and Supple Hand

Phthalate-Free
Exceptional Durability

- SCL-001 ADMIRAL
- SCL-002 ALMOND
- SCL-003 AMERICAN BEAUTY
- SCL-004 BERRY
- SCL-005 BLACK
- SCL-006 BLUE RIDGE
- SCL-007 BRICK
- SCL-008 BRITISH TAN
- SCL-009 BUFF
- SCL-010 BURGUNDY
- SCL-011 CASHEW
- SCL-012 CAYENNE
- SCL-013 CELERY
- SCL-014 CHOCOLATE
- SCL-015 CLARET
- SCL-016 DOE
- SCL-017 FOREST
- SCL-018 FUDGE
- SCL-019 GRANITE
- SCL-020 GRAPE
- SCL-021 HAZELNUT
- SCL-022 IRIS
- SCL-023 IVY
- SCL-024 KILIMANJARO
- SCL-025 MIST
- SCL-026 MOCHA
- SCL-027 NAVY
- SCL-028 ORCHARD
- SCL-029 PAPYRUS
- SCL-030 PERSIMMON
- SCL-031 PEWTER
- SCL-032 ROUGE
- SCL-033 ROYAL
- SCL-034 SADDLE
- SCL-035 SAFFRON
- SCL-036 SAGE
- SCL-037 SHETLAND
- SCL-038 SPRAY
- SCL-039 SPRUCE
- SCL-040 STONE
- SCL-041 TAUPE

- SCL-042 WHITE
- SCL-101 BAYOU
- SCL-102 CHAMOIS
- SCL-103 CHAMOMILE
- SCL-104 CREAMERY
- SCL-105 CURRANT
- SCL-106 FOG
- SCL-107 LAKE
- SCL-108 MARSHMALLOW
- SCL-109 MUSTANG
- SCL-110 OREGANO
- SCL-111 REEF
- SCL-112 RODEO
- SCL-113 SCALLION
- SCL-114 TANDOOR
- SCL-115 WATER
- SCL-201 Aniseed
- SCL-202 Appalachian
- SCL-203 Barley
- SCL-204 Bedrock
- SCL-205 Buttercream
- SCL-206 Carnation
- SCL-207 Citrine
- SCL-208 Comet
- SCL-209 Daffodil
- SCL-210 Fern
- SCL-211 Flan
- SCL-212 Galleon
- SCL-213 Granny Smith
- SCL-214 Gunite
- SCL-215 Gypsum
- SCL-216 Horizon
- SCL-217 Malbec
- SCL-218 Maui
- SCL-219 Morel
- SCL-220 Mortar
- SCL-221 Picholine
- SCL-222 Porcini
- SCL-223 Safflower
- SCL-224 Wave
- SCL-225 Wisp

CLEANING INSTRUCTIONS:

- Prompt cleaning is always recommended. Ordinary dirt and stains can be removed with a mild soap and water. Spot clean the soiled area with the above mentioned soap and water mixture. Dab with a lint free cloth until semi dry. Air dry or dry quickly with the warm setting of a hair dryer. Do not use any concentrated household, ammonia or bleach based cleaners.



Resilience^{SR} represents the latest technology in faux leather and vinyl protection enhancing performance where it is needed the most:

STAIN RESISTANCE: With proper care, materials treated with Resilience^{SR} can be easily cleaned and will guard against stains; maintaining the desired surface appearance for years to come.

ABRASION RESISTANCE: Resilience^{SR} provides additional wear properties and surface durability to any vinyl or faux leather, thereby increasing the life of the material.

Resilience^{SR} is not visible, and does not affect the hand of the material. Resilience^{SR} is engineered to last, even after repeated cleaning and wear. Specify Resilience^{SR} for the most demanding healthcare and hospitality applications!

SYMPHONY GLAZE

MANUFACTURED TO MEET THE FOLLOWING CODES:

- Motor Vehicle Safety Standard 302
- California Tech Bulletin 117 Section E
- Class Ratings: ASTM D 3690 - Class A
- BIFMA • NFPA 260 • UFAC Class 1
- Boston Fire Dept. Code BFD IX-1
- IMO A.652 (16) 8.2 and 8.3
- ASTM E84: Class I or A Rating

FINISHES and TREATMENTS:

- Abrasion - heavy duty: Wyzenbeek 100M
- Sulfide stain resistance • Cold Crack -10 F
- UV stabilized pigments: 200 hours min
- Anti-bacterial and anti-microbial

SPECIFICS:

- Width 54"
- Roll 30 Yds.
- Weight 36 ozs.
- Thickness 1.1mm
- Backing: Woven Poly Cotton

SUITABLE APPLICATIONS:

- Contract
- Residential
- Hospitality
- Automotive • RV

CLEANING INSTRUCTIONS:

• Clean with mild soap and water. Rinse the cleaned area with clean water and dry with lint-free cloth. Suede will resist, without serious discoloration, the repeated action of normal dilution of non-abrasive chlorine or ammonia-based cleaners.



SGL-001	AMBER	SGL-015	SIENNA
SGL-002	BRUNETTE	SGL-016	WHITE CHOCOLATE
SGL-003	CEDAR	SGL-101	BEACH
SGL-004	FLAME	SGL-102	CACTUS
SGL-005	HIDE	SGL-103	CROCUS
SGL-006	HONEY	SGL-104	HAZE
SGL-007	KIWI	SGL-105	HURON
SGL-008	LICORICE	SGL-106	LANDSCAPE
SGL-009	MANGO	SGL-107	PUMICE
SGL-010	MARINE	SGL-108	REGATTA
SGL-011	MEADOW	SGL-109	SANGRIA
SGL-012	NECTARINE	SGL-110	SLATE
SGL-013	SEQUOIA	SGL-111	TANNERY
SGL-014	SHIRAZ	SGL-112	WARM WHITE

	YARD	10 YDS	30 YDS
Width: 54"	50.90	46.80	42.60

SYMPHONY SAN REMO

MANUFACTURED TO MEET THE FOLLOWING CODES:

- Motor Vehicle Safety Standard 302
- California Tech Bulletin 117 Section E
- BIFMA
- UFAC Class 1
- IMO A.652 (16) 8.2
- NFPA 260

FINISHES and TREATMENTS:

- Abrasion - heavy duty: Wyzenbeek 100,000 cycles
- Cold Crack -10 F

SPECIFICS:

- Width: 54"
- Weight: 36 ozs.
- Thickness: 1.1mm
- 30 yard roll
- Backing: Woven Poly Cotton

SUITABLE APPLICATIONS:

- Residential • Office
- Automotive • RV
- Hospitality
- Contract

CLEANING INSTRUCTIONS:

• Clean with mild soap and water. Rinse the cleaned area with clean water and dry with lint-free cloth. Without serious discoloration, San Remo will resist the repeated action of normal dilution of non-abrasive chlorine or ammonia-based cleaners.



SSR-001	BOURBON
SSR-002	COGNAC
SSR-003	ECLIPSE
SSR-004	MADEIRA
SSR-005	PINECONE
SSR-006	POMEGRANATE
SSR-007	PRUSSIAN BLUE
SSR-008	REED
SSR-009	TRUFFLE

	YARD	10 YDS	30 YDS
Width: 54"	53.80	49.50	45.10

SYMPHONY VINTAGE

MANUFACTURED TO MEET THE FOLLOWING CODES:

- Motor Vehicle Safety Standard #302
- California Tech Bulletin 117, Section E
- Federal Standard 191-A Method 5874
- Ultra Violet Resistance - 200 hours ASTM G26-96 Method C
- BIFMA • UFAC Class 1 • NFPA 260
- IMO A 652 (16) 8.2 and 8.3
- ASTM E84: Class I or A

FINISHES and TREATMENTS:

- Abrasion - heavy duty (Wyzenbeek)
- Cold Crack -10

SPECIFICS:

- Width: 54"
- Weight: 36 oz.
- Thickness: 1.1 mm
- 30 yard roll
- Backing: Woven Poly Cotton

SUITABLE APPLICATIONS:

- Hospitality
- Office • Contract
- Residential • RV

CLEANING INSTRUCTIONS:

• Clean with mild soap and water. Rinse the cleaned area with clean water and dry with lint-free cloth. Suede will resist, without serious discoloration, the repeated action of normal dilution of non-abrasive chlorine or ammonia-based cleaners.



SVI-001	ALE	SVI-009	OLD COUNTRY
SVI-002	CHAMOIS	SVI-010	PAPRIKA
SVI-003	COAL	SVI-011	PORT
SVI-004	CYPRESS	SVI-012	PRETZEL
SVI-005	ENGLISH TOFFEE	SVI-013	SHERRY
SVI-006	MIDNIGHT	SVI-014	TOBACCO
SVI-007	MOSS	SVI-015	WICKER
SVI-008	OLD BRONZE		

	YARD	10 YDS	30 YDS
Width: 54"	49.20	45.20	41.20

INFINISS™

CLASSIC LUXURY - SUPERIOR PERFORMANCE

Produced by ISO 9001 Certified Company

The next generation of fine leather alternative is:

- Waterproof • Mildew resistant
- Sulfide, urine, sweat and acid stain resistant
- Inherently anti-microbial
- 1½ times more UV resistant than most vinyl based products
- Backed with a polyester blend for less stretch and more moisture resistance than other alternatives
- Soft and very tough (100,000 double rubs using the wire screen abradent)
- A workroom joy to sew and upholster
- Comfortable to sit on in all climates
- Washable and dry cleanable
- More environmentally sound than PVC base products

SUITABLE APPLICATIONS:

- Automotive
- Aircraft
- Marine
- Hospitality
- Healthcare
- Home and office

CLASSIC LUXURY - SUPERIOR PERFORMANCE

Produced by ISO 9001 Certified Company

TEXUEDE

ULTRASOFT TOUCH - SUPERIOR PERFORMANCE

Texuede SP possesses the luxurious soft touch of kid suede which no other imitation suede can match. This distinctive product uses a unique, ultra fine microfiber; not standard microfiber. This exquisite fineness in the fiber produces a soft touch with a luxurious nap much like genuine suede. Texuede SP is both strong and lightweight and backed with a non-stretch fabric to prevent sagging.

DURABILITY

Texuede SP looks exquisite, yet is exceptionally durable. It passes 100,000+ double rubs on the Wyzenbeek wire screen test. This is more than 6 times the industry standard for heavy-duty abrasion resistance.

COMFORTABLE LUXURY

Thanks to new technology, Texuede SP breathes. Air and moisture transmit easily, so the fabrics stays soft and comfortable. This makes the product feel cool in the summer and warm in the winter.

EASY CARE & HANDLING

Texuede SP is water repellent treated. Liquid spills will bead up on the surface and immediately wiping with an absorbent, dry cloth is usually sufficient. Everyday stains can be spot cleaned with mild detergent and water.

Tough, stubborn stains may be removed with a mild cleaning fluid followed with a clean water rinse.

Removable

covers such as for cushions, pillows and slip covers constructed of Texuede SP, may be machine washed on a delicate cycle in warm water up to 104°F. Use neutral, mild detergent. DO NOT USE BLEACH. Tumble dry on a low

setting, or hang to dry in a shady area. Do not twist or wring, and avoid drying in the sun. Ironing may be used

on the rear side of Texuede SP. Texuede SP covers may also be professionally dry cleaned on a short, soft cycle using commercially acceptable dry cleaning solvents.

NATURE FRIENDLY

Texuede SP is produced using environmentally safe processes and materials.

- Micro-Fiber
- Ultrasoft
- Durable
- Comfortable
- Luxurious
- Easy care
- Nature friendly
- Superior wear

A Revolution in Faux Leather Luxury

FAUX LEATHER	COLORS	YDS/RL	CUTS	ROLLS
AIRE SI MAYA	26	40	85.50	76.00
CONTESSA CONTRACT	25	40	57.50	48.00
CONTESSA TUSCANY	25	40	57.50	48.00
NUVTEX BERRETTA	14	40	57.50	48.00
NUVTEX BIG BIRD	14	40	62.50	53.00
NUVTEX CROCO	9	40	56.00	46.50
NUVTEX GATOR	10	40	57.50	48.00
NUVTEX PATENT	10	40	56.00	46.50
SKINTEX DISTRESSED	22	50	62.50	53.00
SKINTEX ESSENCE	22	50	62.50	53.00

FAUX SUEDE	COLORS	YDS/RL	CUTS	ROLLS
SKINTEX SF LYCHEE RELOADED4	4	50	62.50	53.00
SKINTEX OSTRICH	28	50	56.00	46.50
SKINTEX SF PROVENCE	14	50	56.00	46.50
SKINTEX SNAKE	16	50	56.00	46.50
TEXUEDE SOAVE	22	50	34.50	25.00
TEXUEDE SP	31	50	57.50	48.00

CELLULOSE WOVEN

RAPHIA COLLECTION	COLORS	YDS/RL	CUTS	ROLLS
ANTIGUA (new 42" Width)	4	30	54.50	45.00
AZTEC (new 42" Width)	4	30	54.50	45.00
SAMOA (new 42" Width)	8	30	54.50	45.00

RAVE™



PERMABLOK³®
ADVANCED VINYL PROTECTION

GENERAL CHARACTERISTIC:

- Ultrasoft leather feel
- Excellent tailorability
- Superior wear resistance (100,000 cycles)
- 100% dyed cotton backing

MANUFACTURED TO MEET

THE FOLLOWING CODES:

- BIFMA Class A
- UFAC Class 1
- California Technical Bulletin #117 Section E
- Motor Vehicle Safety Standard 302
- NFPA 260 - Class 1
- IMO A.652(16) 8.2 & 8.3
- Rave™ may comply with Cal 133 when tested with suitable components.

(This term and any corresponding data refer to the typical performance in the specific tests indicated and should not be construed to imply the behavior of this or any other material under actual fire conditions.)

FINISHES and TREATMENTS:

- Superior abrasion resistance
100,000 cycles Wyzenbeek/CFFA-1, Federal Standard 191A - Method 5304, wire screen.
- Mildew resistant
- UV stabilized pigments
- Light fastness: 1000 Hours
- Anti-microbial and anti-bacterial

SUITABLE APPLICATIONS:

- Contract Interiors
- Office
- Restaurant
- Hotel • Motel • Casino
- Healthcare • Assisted Living
- Marine • RV • Auto
- Residential

SPECIFICS

- Width: 54"
- Weight: 27oz
- Yards Per Roll: 25

THE BEST ALTERNATIVE TO LEATHER

When you are looking for a great alternative to leather with the genuine feel and appearance of a natural, aniline-dyed hide, look no further than Spradling's latest introduction - RAVE™. Developed with a unique composite formula, RAVE incorporates both urethane and vinyl chemistry coated on an exclusive Italian dyed-cotton textile, capturing the warm, aesthetic features discriminating buyers seek at a fraction of the cost.

RAVE's palette of 15 colorways was carefully selected to appeal to multiple markets; automotive, contract, marine, and general upholstery. To support these universal applications, RAVE has been engineered with Spradling's PermaBLOK³®, a unique proprietary topcoating system providing superior abrasion performance (100,000 double-rubs), stain resistance, and anti-microbial/anti-bacterial protection. Additionally, as noted on the back panel of your enclosed RAVE sample card, a full range of flammability, mildew, and UV additives are included to ensure maximum field performance.

DESIGNER'S CHOICE

- | | |
|-------------------------|--------------------|
| RAV-2601—DARK GRAPHITE— | RAV-2615—BORDEAUX |
| RAV-2604—TAN | RAV-2616—MEADOW |
| RAV-2605—SANDSTONE | RAV-2617—MOSS |
| RAV-2606—LIGHT CHARCOAL | RAV-2618—HUNTER |
| RAV-2609—DESERT | RAV-2619—RUBY RED |
| RAV-2612—BUTTERSCOTCH | RAV-2621—SAPPHIRE |
| RAV-2613—TURMERIC | RAV-2623—ESPRESSO |
| RAV-2614—POMEGRANITE | RAV-2624—BLACK INK |

Width: 54"	YARD	10 YDS	25 YDS
	71.50	63.20	56.10



DOLCE

THE SOFT & SUPPLE HAND OF POLYURETHANE

GENERAL CHARACTERISTIC:

- Ultrasoft leather feel
- Excellent tailorability
- Superior wear resistance (100,000 cycles)
- 100% dyed cotton backing

MANUFACTURED TO MEET

THE FOLLOWING CODES:

- ASTM E 84 Adhere - Class 1
- EN 1021 - Part 1 & 2
- California Technical Bulletin #117 Section E
- Motor Vehicle Safety Standard 302
- NFPA 260 - Class 1
- IMO A.652(16) 8.2 & 8.3
- BS 5852 - Source #0

(This term and any corresponding data refer to the typical performance in the specific tests indicated and should not be construed to imply the behavior of this or any other material under actual fire conditions.)

FINISHES and TREATMENTS:

- Superior abrasion resistance
400,000 cycles Wyzenbeek/CFFA-1
- Cold Crack
- UV stabilized pigments
- Light fastness: 40 Hours
- Tear and Tensile Strength
- Hydrolytic Stability

SUITABLE APPLICATIONS:

- Corporate Interior
- Office
- Restaurant
- Hotel • Motel • Casino
- Healthcare
- Marine • RV • Auto
- Residential
- Sun Rooms

SPECIFICS

- Width: 54"
- Weight: 40oz
- Yards Per Roll: 30

- | | | |
|----------------|--------------------|-------------------|
| DOL-6712 MOCHA | DOL-6718 TANGELO | DOL-6714 BURGUNDY |
| DOL-6701 WHITE | DOL-6719 POPPY | DOL-6715 FOG |
| DOL-6702 IVORY | DOL-6720 FUCHSIA | DOL-6716 BRAMBLE |
| DOL-6703 ECRU | DOL-6721 CITRON | DOL-6722 GRASS |
| DOL-6704 DUNE | DOL-6727 METEOR | DOL-6723 PEACOCK |
| DOL-6705 SAND | DOL-6708 MUSHROOM | DOL-6724 JET |
| DOL-6706 LATTE | DOL-6709 CAMEL | DOL-6725 INDIGO |
| DOL-6707 CUMIN | DOL-6710 LION | DOL-6726 ARTESIAN |
| DOL-6717 MOSS | DOL-6711 RUSSET | DOL-6728 BLACK |
| | DOL-6713 CHOCOLATE | |

CHARACTERISTICS

- 7-Year Hydrolytic Stability
- No Heavy Metals
- Formaldehyde Free
- Easily Cleaned
- Scratch Resistant
- Exceptional Color Fastness



Width: 54"	YARD	10 YDS	25 YDS
	66.20	58.00	49.90



WOLLSDORF LEATHER

Wollsdorf Leather Tannery is located near Graz, Austria. Wollsdorf has been operating for over 70 years and is recognized world wide for their highly advanced production and environmental techniques. Utilizing Austrian and South German cattle hides only, Wollsdorf offers some of the highest quality leathers in the world.

FURNITURE LEATHERS

FINESSE: Finesse is an all natural full grain aniline through-dyed leather with a light top finish to provide protection and easy maintenance. Finesse derives from the top 20% of the raw hide selections. Available in 75 colors.

ALPIN: This is a full grain, semi-aniline, drum-dyed leather which is tanned free of chrome. It is intermediately embossed for uniform grain structure, and has a soft hand. Available in 18 colors.

EUROGLAZE: An antique leather protective finish of top grain aniline through-dyed leather with a two tone effect and a high lustre finish to achieve an antiqued appearance. Suitable for upholstery and desk top applications there are 8 colors available in this quality.

MAMMUT: This is a top grain aniline through-dyed leather. The finish provides great protection and maintains even coloration throughout each hide with a luxurious hand and appearance. Available in 32 colors.

FOC EARTH: "Free of Chrome" leather; an environmentally friendly leather. Available in 31 colors.

These manufacturers of quality automobiles and furniture use Wollsdorf Leather!

FURNITURE	AUTOMOTIVE
* Baker Furniture	* Audi / VW
* Bernhardt	* BMW
* Brickel & Assoc.	* De tomaso
* Carolina Bus. Furn.	* Ford
* Chromcraft	* Honda
* Davis Furniture	* Lamborghini
* Domore	* Mercedes G
* Geiger International	* Mitsubishi
* Grahl Mfg.	* Nissan
* Hag - USA	* Opel
* Krueger Inter.	* Porsche
* Trendway	* Renault
* United Chair	* Subaru

54" FABRIC YARDS	LEATHER SQUARE FEET
1 =	18
2 =	36
3 =	54
4 =	72
5 =	90
6 =	108
7 =	126
8 =	144
9 =	162
10 =	180

	FULL HIDES Per Sq Ft
FINESSE	13.90
ALPIN	13.90
EUROGLAZE	12.80
MAMMUT	10.40
SPS SHIELDED LEATHER	12.60
AUTO: DAKOTA	12.10
AUTO: CATANIA	12.10
AUTO: NAPA EXCLUSIVE	13.60
AUTO: KOOL BLACK	14.90
AIRCRAFT: AMBASSADOR	18.50
FOC EARTH	15.00

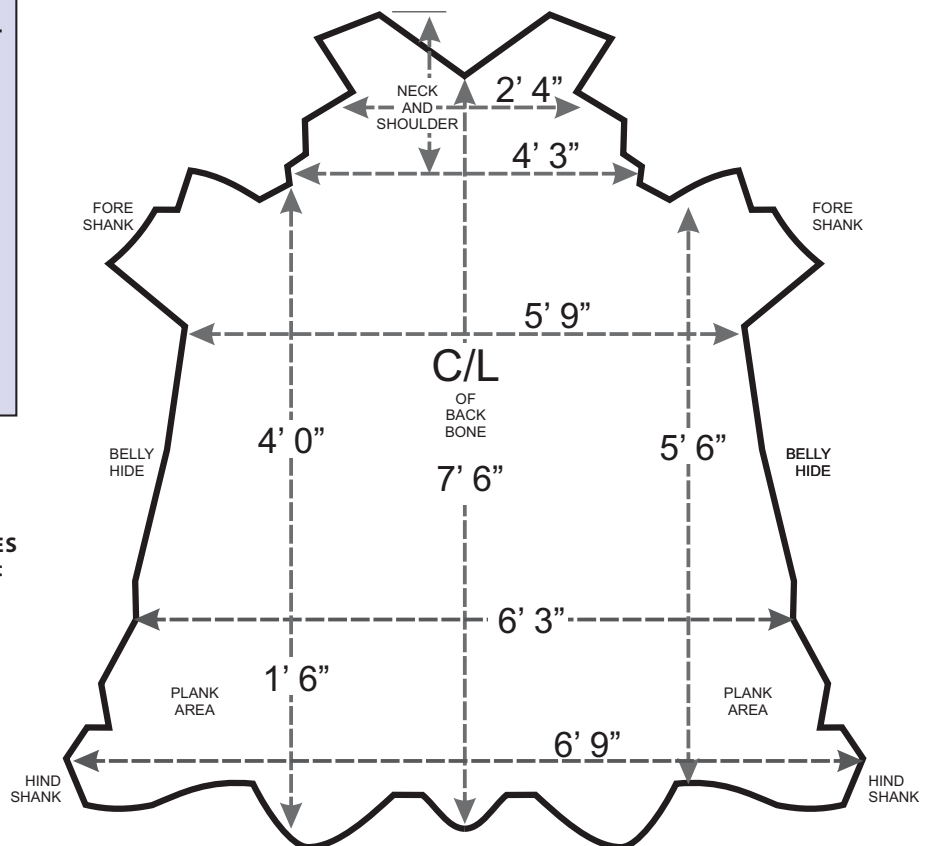

WOLLSDORF AMBASSADOR AIRCRAFT LEATHER



- Passes FAR 25.853(a) Amendment 25.72 (Vertical)
- Flameproofed during tanning
- FAA form 8110-3 certification with all shipments
- Top grain leather
- 100% aniline through-dyed
- Superior selection of Austrian and South German Hides
- Hides average 60 square feet in size
- Technically advanced specially formulated protective finish for aircraft applications
- Exceeds 2,000 rubs for abrasion (ASTM D3884-80)
- Produced under ISO-9001 quality standards
- **AVAILABLE IN 29 COLORS**

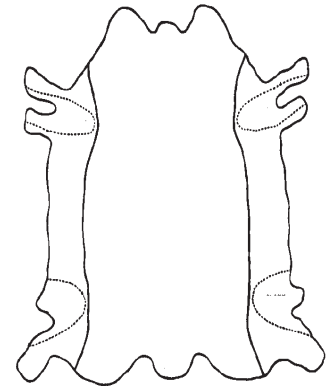

Austrian Leather

AMBASSADOR

HALF HIDES
per sq ft
21.30

FULL HIDES
per sq ft
18.50

CUSTOM EMBOSSED

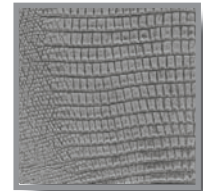
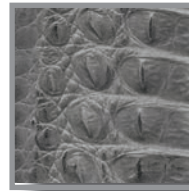
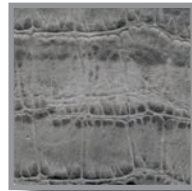
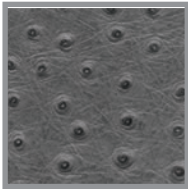

WHAT A CROC
LA GARTO - Lizard
OSTRICH
SARKARA - Alligator
TEYUS - Lizard
VAQUERO - Crocodile

COLORS	Average sq ft	per sq ft
14	45	17.70
1	45	38.60
5	45	18.10
3	45	37.20
5	45	18.10
3	45	18.90

*Delivery ime: 4 to 6 working days
2"x 4" sample sets are available*

BLACK LEATHER

GENERAL CHARACTERISTICS:

- Top Grain Leather
- Vat Dyed
- Small Pebble Grain

SUITABLE APPLICATIONS:

- Furniture
- Automotive aftermarket

FEATURES:

- Square feet per hide: 48-50
- Flammability: FMVSS-302
- Lightfastness: 200 hours
- Abrasion - 10,000 double rubs

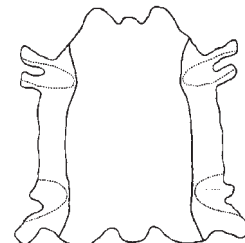

BASIC BLACK

FULL HIDES
per sq ft
9.00

MARATHON CONTRACT FABRIC

MANUFACTURED TO MEET THE FOLLOWING CODES:

- Abrasion: > 250,000 double rubs ASTM-D-4157 Wyzenbeek
- Strength retention (ASTM D 5034) exceeds 50% strength retention @ 400 hours Xenon Arc

FINISHES and TREATMENTS:

- 100% Polyolefin
- Finish: Teflon^o
- Lightfastness: (AATCC 16E) Class 5 @ 400 hours
- Crocking (AATCC 8)
- Wet - Class 4,5 Dry - Class 5
- Soil and stain repellent
- Class 1: Passes
- Pattern direction: Down-the-roll

FLAME RESISTANCE:

- California Bulletin 117, Section E, Passes
- ASTM E84, Class 1
- UFAC, Class 1
- MVSS 302, Passes

SPECIFICS:

- Width: 54"
- Weight: 16 oz. lineal yard
- 50 yard roll

CLEANING:

Use water or solvent based cleaners.



Arena



Healthcare



Theater



Institutions



Hospitality



Sky Box



Business



Bldgs. of Worship

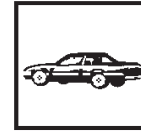

Automotive



Public Transportation



Teflon[®]
Fabric Protector

31 Colors!

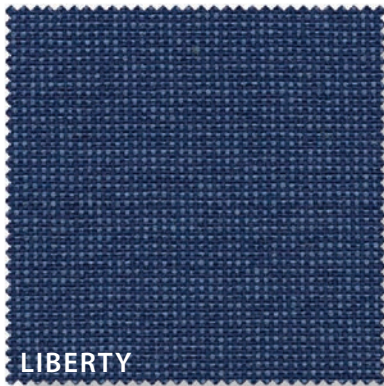

- AMETHYST
- ASPEN
- BASIL
- BLACK
- BRICK
- BROWN
- CADET
- CHARCOAL
- CHOCOLATE
- CLARET
- COAL
- DARK BLUE
- EARTH
- EMERALD
- FEDERAL
- GOLD DUST
- HOLLY
- INDIGO
- KHAKI
- LIBERTY
- LILAC
- MAROON
- MOCHA
- OYSTER
- SABLE
- SAPPHIRE
- SCARLET
- SLATE
- TARRAGON
- TUMBLEWEED
- WALNUT

Width: 54"	YARD 30.50	10 YDS 28.30	25 YDS 26.30	50 YDS 23.90
------------	---------------	-----------------	-----------------	-----------------

MAGIC

MANUFACTURED TO MEET
THE FOLLOWING CODES:

- UFAC Class 1
- California Technical Bulletin #117
- Abrasion: Passes 12,000 #8 cotton duck
- Abrasion: Passes 102,000 wire screen

SPECIFICS:

- Width: 54"
- Weight: 12.3 oz. lin. yd.
- Content: 100% Polyester
- Cleaning code: SW

Width: 54" **YARD 26.90**

FAUX SUEDE

AUBERGINE	DOESKIN	LIPSTICK	RUST
BLACK	DUSTY ROSE	MELON	SAGE
BRICK	EARTH	MICA	SEA
BUCKSKIN	ESPRESSO	MIDI	SEAFOAM
CAMEL	FAWN	MOSS	SKY
CELERY	GREENBAY	NAVY	STONE
CHARCOAL	HUNTER	NU MOCHA	SUNSHINE
CHESTNUT	INDIGO	OLIVE	TIDE POOL
CHOCOLATE	KHAKI	OYSTER	TURQUOISE
CINNABAR	KIWI	PARCHMENT	WINE
CLOUD	LICHEN	PEAT	
COPPER	LIME	PUMPKIN	

CHARM

MANUFACTURED TO MEET
THE FOLLOWING CODES:

- UFAC Class 1
- California Technical Bulletin #117
- Abrasion: Passes 102,000 #8 cotton duck
- Abrasion: Passes 15,000 wire screen

SPECIFICS:

- Width: 54"
- Weight: 25.6 oz. lin. yd.
- Content: 100% Polyester
- Cleaning code: SW

Width: 54" **YARD 48.90**

CLASSIC CHENNILE

AQUAMIST	CHOCOLATE	OLIVE
BASIL	CINNAMON	ONYX
BEIGE	CLAY	RED
BRICK	COGNAC	SAGE
BRONZE	EGGPLANT	SAND
CAFÉ	HONEY	STONE
CANYON	INDIGO	WILLOW
CHAMOIS	MOSS	

ABBEY

Jacquard with Woven Cross

For Churches and Theaters

MANUFACTURED TO MEET
THE FOLLOWING CODES:

- California Technical Bulletin #117
- Abrasion: > 100,000 double rubs
- UFAC Class 1
- ASTM E-84 Class A
- Fabric protectant: Teflon
- Cleaning code: WS
- Lightfastness: > 40 Hours
- Crocking: Dry Class 5
Wet Class 5



SPECIFICS:

- Width: 54"
- 72% Olefin / 28% Polyester
- Weight per yard: 11oz
- Repeat: 4.84"HT x 4.40"WD
- Pattern sampled: Railroaded

CARDINAL
RED
NAVY
GREEN
PURPLE
JAZZ



Width: 54" **YARD 35.90** **10 YDS 34.10** **25 YDS 32.40** **50 YDS 31.40**

MOHAIR VELOUR

*Ideal For: • Symphony Halls • Auto Interiors • Theaters
• Hotel lobbies • Offices • Homes*

MANUFACTURED TO MEET
THE FOLLOWING CODES:

- UFAC Class 1
- MVSS-302
- CS191-53
- BIFMA
- California Technical Bulletin #117
- Abrasion: > 50,000 double rubs
rated heavy duty
- Light fastness: 60 hours
- Cleaning Code: S

SPECIFICS:

- Width: 54"
- 100% Mohair pile

332 Ivory	645 Indigo
340 Maple	697 Royal
345 Pumpkin	766 Celery
350 Rust	799 Hunter
380 Crimson	833 Sky Gray
390 StoneBrown	895 Elephant
395 Dark Chocolate	897 Gunmetal
494 Merlot	999 Black



Width: 54" **YARD 189.80** **10 YDS 179.80** **30 YDS 170.80** **60 YDS 153.90**

WOOL VELOUR

*Ideal For: • Symphony Halls • Auto Interiors • Theaters
• Hotel lobbies • Offices • Homes*

MANUFACTURED TO MEET
THE FOLLOWING CODES:

- UFAC Class 1
- MVSS-302
- California Technical Bulletin #117
- CS191-53
- BIFMA
- Abrasion: > 50,000 double rubs
rated heavy duty

SPECIFICS:

- Width: 54"
- 100% Wool pile

332 Tan	765 Celery
395 Dark Chocolate	799 Hunter
433 Pink	833 Gray
494 Merlot	897 Gunmetal
645 Indigo	999 Black
697 Royal	



Width: 54" **YARD 101.30** **10 YDS 95.90** **30 YDS 91.10** **60 YDS 86.20**

VELCRO HOOK & LOOP SEWING TAPE

PRICED PER SIDE

WIDTH	COLOR	TYPE	YARD	25 YDS	100 YDS	500 YDS
5/8"	Black	Hook or Loop	1.90	.70	.60	.46
5/8"	White	Hook or Loop	1.90	.70	.60	.46
3/4"	Black	Hook or Loop	2.00	.80	.70	.52
3/4"	White	Hook or Loop	2.00	.80	.70	.52
3/4"	Beige	Hook or Loop	2.00	.80	.70	.52
1"	Black	Hook or Loop	2.50	.88	.80	.56
1"	White	Hook or Loop	2.50	.88	.80	.56
1"	Beige	Hook or Loop	2.50	.88	.80	.56
1"	Silver	Hook or Loop	2.50	.88	.80	.56
1 1/2"	Black	Hook or Loop	2.70	1.32	1.20	.84
1 1/2"	White	Hook or Loop	2.70	1.32	1.20	.84
1 1/2"	Beige	Hook or Loop	2.70	1.32	1.20	.84
2"	Black	Hook or Loop	3.00	1.74	1.60	1.12
2"	White	Hook or Loop	3.00	1.74	1.60	1.12
2"	Silver	Hook or Loop	3.00	1.74	1.60	1.12
4"	Black	Hook or Loop	5.00	3.00	2.80	2.40
4"	White	Hook or Loop	5.00	3.00	2.80	2.40



Velcro Construction: Nylon

ADDITIONAL
COLORS AVAILABLE
SPECIAL ORDER
25 YARD MINIMUM

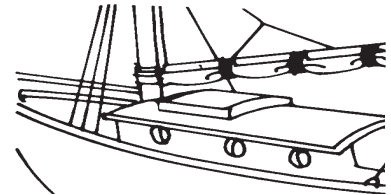

VELCRO SPECIFICATIONS

- 100% nylon woven tape
- High quality thermo and cold resistant, chemical-resistant and excellent electric insulation
- Heat resistance: becoming soft at 180°C and melted during 215°C-220°C
- Cold resistance: usable under -30°C; the lower the temperature, the stronger the tensile force
- Hook: approximately 324 hooks per square inch
- Loop: approximately 740 loops per square inch
- Material thickness: 1.9 to 2.1mm

DURABILITY

PEELING CYCLE

2,000 times
5,000 times
10,000 times
20,000 times

CLOSURE STRENGTH REDUCING RATE

10% under
15% under
20% under
30% under

CHANGE ON LOOP TAPE

No fluffing
Little fluffing
Obvious fluffing
Fluffing throughout

CLOSURE STRENGTH

LATERAL TENSILE STRENGTH

(Closure length 50 mm)

Width	In Pounds	In Kilograms
5/8"	11.0 above	5.0 above
3/4"	15.4 above	7.0 above
1"	19.8 above	9.0 above
1 1/2"	26.5 above	12.0 above
2"	36.4 above	16.0 above
4"	68.3 above	31.0 above

VERTICAL PEELING STRENGTH

(Closure length 50 mm)

In Pounds	In Kilograms
0.28 above	130g above
0.39 above	180g above
0.46 above	210g above
0.59 above	270g above
0.70 above	320g above
1.21 above	550g above

RUBBER PRESSURE SENSITIVE TAPE SPECIFICATIONS

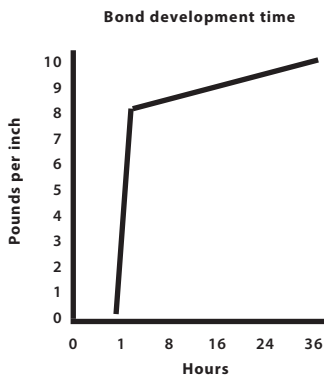

HB@2081 rubber pressure sensitive tape is a high temperature rubber base pressure sensitive adhesive, designed for use in applications for high tack and quick setting such as packaging, medical, toys and others.

- 90% bond strength in an hour and full strength in 24 hours
- Resists temps in range 0°F to 180°F

Recommended substrates: • ABS • Acrylic Sheet • Aluminum • Ceramic Tile • Elpo Panel • Glass • Lacquered • Raw Plywood • Polyethylene • Polypropylene • Raw Steel • Rigid Vinyl

	UNIT	AVERAGE	UNIT	AVERAGE
PEEL ADHESIVE (PSTC-1)	kg / cm	1.3	pound / inch	7.28
HOLDING POWER (PSTC-1)	MINUTE	ABOVE 4000	MINUTE	ABOVE 4000
SAFT (500G / inch)	°C	83	°F	181.4
	MINUTE	109.5	MINUTE	109.5

VELCRO HOOK & LOOP ADHESIVE BACKING



PRICED PER SIDE

Velcro Construction: Nylon

ADDITIONAL
COLORS AVAILABLE
SPECIAL ORDER
25 YARD MINIMUM



WIDTH	COLOR	TYPE	YARD	25 YDS	100 YDS	500YDS
5/8"	Black	Hook or Loop	2.70	1.42	1.30	.96
5/8"	White	Hook or Loop	2.70	1.42	1.30	.96
3/4"	Black	Hook or Loop	2.80	1.52	1.40	1.06
3/4"	White	Hook or Loop	2.80	1.52	1.40	1.06
3/4"	Beige	Hook or Loop	2.80	1.52	1.40	1.06
1"	Black	Hook or Loop	3.00	1.64	1.60	1.16
1"	White	Hook or Loop	3.00	1.64	1.60	1.16
1"	Beige	Hook or Loop	3.00	1.64	1.60	1.16
1 1/2"	Black	Hook or Loop	4.00	2.62	2.40	1.95
1 1/2"	White	Hook or Loop	4.00	2.62	2.40	1.95
2"	Black	Hook or Loop	4.50	3.48	3.20	2.32
2"	White	Hook or Loop	4.50	3.48	3.20	2.32
4"	Black	Hook or Loop	7.80	6.00	5.60	4.80
4"	White	Hook or Loop	7.80	6.00	5.60	4.80



VELCRO HOOK & LOOP SUPER ADHESIVE



- Velcro Construction: Nylon
- Particularly suited for strong bonds to metals, vinyls and other plastics
- Withstands temperatures in excess of 300° F

Acrylic adhesive

WIDTH	COLOR	TYPE	YARD	25 YDS	100 YDS	500 YDS
1"	Black	Hook or Loop	4.50	3.80	3.30	2.80
2"	Black	Hook or Loop	9.00	7.60	6.60	5.60



MARINE ADHESIVE TRANSFER SEAM TAPE

This tape has a very sticky clear strip on both sides. When rolled onto a fabric surface, another fabric may then be laid over it to which it will adhere and be ready for sewing. This eliminates slippage and helps prevent seam leakage.

Width	60 YD/ROLL	10 ROLLS
1/4"	21.50	19.90
1/2"	30.20	27.90
3/4"	45.20	41.80



3M DUAL LOCK FASTENING SYSTEM

The BEST when hundreds of closures are necessary.

- Solvent and water resistant
- Adhesive is UV and plasticizer resistant
- Good to 200°F

Pressure Sensitive
Adhesive
VERY HIGH BOND

WIDTH	COLOR	YDS/ROLL	YARD	50 YDS
1"	Black	50	13.00	11.50



#5 YKK CHAIN ZIPPERS

	YARD	ROLL	2 ROLLS	
WHITE TAPE	5.96	4.16	4.02	Per yard
BLACK TAPE	5.96	4.16	4.02	Per yard
	EACH	25	100	
DOUBLE TAB PULLS	2.24	2.04	1.84	Per each
SINGLE TAB PULLS	.98	.78	.58	Per each
	BAG	2 BAGS	4 BAGS	
TOP STOPS (100)	9.16	8.16	7.16	Per bag
BOTTOM STOPS (100)	16.30	15.30	14.30	Per bag



BLACK and WHITE
PUT-UP: 218 YARD ROLL



MOULDED NYLON ZIPPERS

#5 YKK JACKET END ZIPPERS

SINGLE PULL SLIDE

SIZE	EACH	12	25	
24"	4.90	4.40	3.90	Per each
36"	5.90	5.40	4.90	Per each
48"	7.00	6.50	6.00	Per each
72"	9.10	8.60	8.10	Per each
84"	10.10	9.60	9.10	Per each



BLACK and WHITE



MOULDED NYLON ZIPPERS

#10 YKK ZIPPER CHAIN

	YARD	ROLL	2 ROLLS
WHITE TAPE	9.90	8.50	7.70
BLACK TAPE	9.90	8.50	7.70
	EACH	25	100
DOUBLE TAB PULLS	4.30	3.90	3.60
SINGLE TAB PULLS	3.30	2.90	2.60
	BAG	2 BAGS	4 BAGS
TOP STOPS	12.90	11.90	10.80
BOTTOM STOPS	21.40	19.80	17.90



BLACK and WHITE
PUT-UP: 109 YARD ROLL



MOULDED NYLON ZIPPERS

#10 YKK JACKET END ZIPPER

SIZE	EACH	12	25
18"	10.70	9.70	8.70
24"	12.00	11.00	10.00
36"	14.60	13.60	12.60
40"	15.40	14.40	13.40
48"	17.20	16.20	15.20
54"	18.50	17.50	16.50
60"	19.70	18.70	17.70
72"	22.30	21.30	20.30
84"	24.90	23.90	22.90
96"	27.50	26.50	25.50
110"	30.50	29.50	28.50
120"	32.60	31.60	30.60

GREAT FOR:
• TENTS
• BOAT TOPS
• AWNINGS



BLACK and WHITE



MOULDED NYLON ZIPPERS
WITH A DOUBLE PULL SLIDE

COMMON SENSE FASTENERS

NICKEL ON BRASS These fasteners are positive locking. Each stud is assembled with a spring attached to the knob or button which holds it under tension until turned by hand preventing accidental opening. Manufacturers of trucks, luggage, leather goods and packaging use "common sense" fasteners.

#450 CUTTING PUNCH TOOL VL-78403



Per each 178.60

#410 SINGLE TWO PRONG CLINCH VL-78332
#410A CLINCH PLATE VL-78507

	1	100	1000
#410	2.24	1.74	1.66
#410A	.66	.18	.16



#400 GROMMET VL-78403
#400A WASHER VL-78505
#400AA WASHER VL-78510

	1	100	1000
#400	.94	.46	.42
#400A	.74	.26	.22
#400AA	.88	.40	.36



400 Grommet & 400A Washer

#404 SINGLE WOOD SCREW VL-78324

	1	100	1000
Per each	3.54	3.04	2.90



#401 SINGLE STUD TWO SCREW BASE VL-78322

	1	100	1000
Per each	2.32	1.82	1.72



#402 DOUBLE TWO SCREW BASE VL-78323

	1	100	1000
--	---	-----	------



LIFT-THE-DOT FASTENERS

NICKEL ON BRASS

NICKEL ON BRASS

#9951 CUTTING PUNCH VL-16205



#9951 143.30 each

#608 SOCKET 7/32" LEG VL-16205
#708A BACK PLATE VL-16506

	10	100	1000
#608	1.66	1.16	1.12
#708A	.92	.44	.40



#952 STUD VL-16360-16
#8 1/2" STAINLESS SCREW

	10	100	1000
Per each	1.94	1.44	1.38



#895 STUD 2 PRONG CLINCH VL-16349
#895A CLINCH PLATE VL-16501

	10	100	1000
#895	1.68	1.18	1.14
#895A	.90	.42	.38



#882 MACHINE STUD VL-16362
8/32" MACHINE SCREW LENGTH: 3/8"

	10	100	1000
Per each	1.60	1.10	1.06



PULL-THE-DOT FASTENERS

Positive locking glove-style fasteners recommended when a strong, quick-release fastener is needed for canvas, leather, rubber coated or plastic fabrics. Especially recommended for marine use on boat tops and covers, sail covers, etc., where high winds disengage the conventional fastener.

A three-sided locking snap fastener with a "built-in" locking feature, it withstands extreme pressure on three sides without unlatching, yet releases instantly on the fourth side by "pulling the dot" on the embossed side. Pull-The-Dots have no sharp edges or protrusions to tear or mar the fabric to be fastened. All parts are made of brass with a phosphur bronze spring-in socket. **FINISH IS NICKEL.**

VL-18100 BUTTON



	1	100	1000
Per Each	1.14	.64	.60

VL-18201 SOCKET



	1	100	1000
Per Each	1.10	.60	.58

VL-18303 STUD



	1	100	1000
Per Each	.84	.34	.32

VL-18307 STUD
#2 Phillips Head Screw #8 x 3/8"



	1	100	1000
Per Each	1.64	1.14	1.08

**NICKEL
ON
BRASS**
UNLESS SPECIFIED

DURABLE SNAP FASTENERS

**NICKEL
ON
BRASS**
UNLESS SPECIFIED

670 BUTTON CAP

11/64 Barrel length
VL-10128
24 Ligne



	100	1,000
PER BOX	29.40	231.60

548 SOCKET

Medium action
VL-10224



	100	1,000
PER BOX	26.50	208.50

665 BUTTON CAP

1/4" Barrel length
VL-10127
24 Ligne



	100	1,000
PER BOX	33.80	266.70

548X SOCKET

Hard action
VL-10224



	100	1,000
PER BOX	30.10	237.30

550 STUD

Regular action
VL-10370



	100	1,000
PER BOX	16.90	131.70

550A EYELET

1/4" Barrel
VL-10412



	100	1,000
PER BOX	15.60	120.80

550DR STUD

Deep recess
VL-10379



	100	1,000
PER BOX	21.10	17.60

550AL EYELET

5/16" Barrel
VL-10413



	100	1,000
PER BOX	15.50	107.00

552 STUD

"Gypsy Stud"
Double stud
VL-10342
Special die for
Press-n-Snap on page 222.



	100	
PER BOX	73.10	725.90

WINDSHIELD CLIPS and STUDS

With brass / nickel stud
and stainless steel clip
VL-10388 3/4" x 9/16"
VL-10391 7/8" x 9/16"



	100	
3/4" BOX	106.40	
7/8" BOX	123.30	

**NICKEL
ON
BRASS**
UNLESS SPECIFIED

DURABLE SNAP FASTENERS

**NICKEL
ON
BRASS**
UNLESS SPECIFIED

MILITARY BLACK SNAPS



TYPE	FINISH	PART #	100
CAP	BLACK	VL10128	31.20
SOCKET	BLACK	VL10224	28.40
STUD	BLACK	VL10370	17.10
EYELET	BLACK	VL10412	15.90

STAINLESS STEEL DURABLE SNAP FASTENERS

High-grade #402
Stainless steel

SIZE: 24 Lignes = 24/40ths = 5/8"



TYPE	FINISH	PART #	100	1000
CAP	NICKEL	VL30028	41.70	348.00
SOCKET	NICKEL	VL30024	46.20	386.00
STUD	NICKEL	VL30070	20.60	172.00
EYELET	NICKEL	VL30014	21.50	179.00

457 STAINLESS STEEL STUD

Self-tapping: 3/8" VL-10393-12
 Self-tapping: 5/8" VL-10393-20
 Self-tapping: 1" VL-10393-25
 OVERSIZED: 5/8" VL-10393-20 OS
#10 SCREW



	100	1,000
#12 3/8"	73.50	507.00
#20 5/8"	73.50	507.00
#32 1"	92.40	638.00
#20 OS 5/8"	104.60	722.00

561 MACHINE STUD

3/8": VL-10708-12
 5/8": VL-10708-20
 10/32 Thread 3/8"
 10/32 Thread 5/8"



PER BOX	100	1,000
	116.40	972.00

TEK SCREW

Self-drilling
 #8 x 7/16" VL-10301



PER BOX	100	1,000
	104.90	724.00

BABY DURABLE SNAP FASTENERS

SIZE: 20 Lignes = 20/40ths = 1/2"



TYPE	FINISH	PART #	100	1000
CAP	NICKEL	VL12105	26.40	216.50
SOCKET	NICKEL	VL12205	23.40	191.40
STUD	NICKEL	VL12303	15.70	127.00
EYELET	NICKEL	VL12402	13.90	111.90

DURA SNAP BUTTON

SIZES: 30 and 36

This nylon back is specifically designed to snap onto a Durable Wood Screw or Durable Stud when covered. Screw the stud into the upholstered panel and snap the covered DuraSnap over it. This economical DuraSnap provides a secure hold with little chance of rust or discoloration.



SHELL and RING

	30	36
GROSS BOX	20.60	23.20

ENAMELED SNAPS

- Colors to match Sunbrella
- Brass posts nickel plated



43-10 Black	43-83 Sapphire
43-15 Bay Brown	43-70 Medium Gray
43-87 Toast	43-65 Maroon
43-80 Neptune Blue	43-75 Navy
43-95 White	43-55 Jockey Red

	100	1000
PER BOX	35.60	245.00

DURABLE DOT DIES

fits Handy Jr.
Button Machine

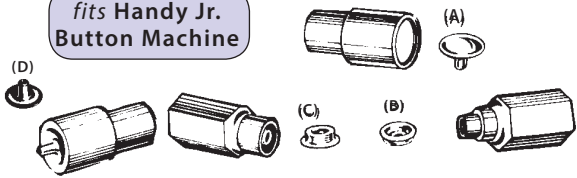

4 dies fit:	A #670 Cap	B #548 Socket	C #550 Stud	D #550A Eyelet (Post)
-------------	-------------------------	----------------------------	--------------------------	---------------------------------------

PART	SET	INDIVIDUAL DIES
4 PART DIE SET	622.20	186.70

HAND SETTING DIES

FOR DURABLE DOTS



Inexpensive hand tool set for attaching all DURABLE 24 line buttons, sockets, studs and eyelets.

Fits: Durable Dots #670 - #548 - #550 - #550A

HAND SETTING DIE	16.20
------------------	-------

PRESS-N-SNAP TOOL and DIES

FOR ATTACHING SNAPS and GROMMETS to:

- UPHOLSTERY • AUTO TOPS • BOAT COVERS
- TENTS • TARPS • CANVAS

EACH TOOL SET INCLUDES:

- Four part Dura-Die Set
- #1 Grommet die

PART	EACH
PRESS-N-SNAP TOOL	344.60
DIE #670	51.90
DIE #548	51.90
DIE #550	54.80
DIE #550A	51.90

PART	EACH
PLUNGER	51.10
WASHER	5.20
#0 GROMMET DIE	98.20
#1 GROMMET DIE	98.20
#2 GROMMET DIE	116.90
HANDLE	51.10
LEVER	27.00
BENCH MOUNT	81.30
BOLT & NUT	6.20
SM. "O" RING	1.00
LG. "O" RING	1.00



Included

PART	EACH
BABY DOT DIES (set of 4)	197.80
PULL THE DOT DIES (each)	64.80
GYPSY DIE	70.00

BRASS SPUR GROMMETS and DIE



#217 DIES

SIZE	EACH
0	103.40
1	110.00
2	113.40
3	131.50
4	141.60

C.S. OSBORNE



SPUR GROMMETS & WASHERS

SIZE	OD	I.D.	GROSS
0	9/16"	1/4"	74.50
1	11/16"	5/16"	84.40
2	13/16"	3/8"	103.90
3	1"	7/16"	119.90
4	1 1/16"	1/2"	157.10
5	1 3/16"	5/8"	189.60

BRASS GROMMETS and WASHERS

SIZE	OD	I.D.	GROSS	5 GROSS	10 GROSS
00	7/16"	3/16"	18.30	16.90	15.30
0	9/16"	1/4"	22.40	20.80	18.70
1	11/16"	5/16"	27.10	25.00	22.60
2	13/16"	3/8"	34.90	32.30	29.20
3	1"	7/16"	55.60	51.40	46.40
4	1 1/16"	1/2"	66.40	61.40	55.40
5	1 3/16"	5/8"	110.60	102.30	92.30
6	1 4/16"	13/16"	318.80	294.90	266.20



NICKEL on BRASS GROMMETS and WASHERS

SIZE	OD	I.D.	GROSS	5 GROSS	10 GROSS
00	7/16"	3/16"	19.20	17.70	16.00
0	9/16"	1/4"	24.10	22.30	20.10
1	11/16"	5/16"	30.00	27.70	25.00
2	13/16"	3/8"	39.20	36.30	32.80
3	1"	7/16"	62.50	57.90	52.20
4	1 1/16"	1/2"	80.40	74.40	67.10
5	1 3/16"	5/8"	122.50	113.30	102.30
6	1 4/16"	13/16"	349.60	323.40	292.00



DULL BLACK FINISH ON BRASS GROMMETS and WASHERS

SIZE	OD	I.D.	GROSS	5 GROSS	10 GROSS
0	9/16"	1/4"	24.50	22.70	20.50
1	11/16"	5/16"	30.60	28.30	25.60
2	13/16"	3/8"	40.20	37.20	33.60
3	1"	7/16"	65.10	60.30	54.40
4	1 1/16"	1/2"	83.90	77.60	70.10



GROMMET HAND DIES and CUTTERS

#216 DIES

SIZE	SET
0	103.40
1	110.00
2	113.40
3	131.50
4	141.60
5	151.60
6	330.20

#500 CUTTERS

SIZE	DIA.	EACH
0	1/4"	52.40
1	5/16"	52.40
2	3/8"	60.30
3	7/16"	60.30
4	1/2"	71.20
5	5/8"	89.40
6	13/16"	97.20



C.S. OSBORNE



HANDY JR. GROMMET DIES

Fits Handy Jr. Button Machine

SIZE	EACH
0	917.20
1	917.20
2	917.20
3	917.20
4	917.20
5	917.20



GROMMET KITS

A complete and inexpensive kit for household use!

Osborne K-235

Each kit contains:

- #235 Grommet Die
- #245 Cutting Punch
- Cutting board (small)
- Complete instructions
- 1 doz. grommets and washers

SIZE	EACH
0	59.00
1	62.70
2	64.80
3	66.10
4	73.10



HIDEM WELT

5/8" CRUSH GRAIN
25 Yard rolls
Color cards available



Custom made Hidem available: 250 yard minimum. Ask for further details.

301 Red	318 Maroon	329 Almond
302 Royal Blue	320 Taupe	330 Firethorn
306 Saddle	321 Tobacco	331 Blue
308 Black	322 Gold	332 Oxblood
309 White	323 Green	333 Charcoal
310 Off White	324 Camel	350 Dark Brown
311 Dark Grey	325 Dark Blue	352 Slate Blue
312 Light Grey	326 Light Blue	353 Graphite
316 Turquoise	327 Willow	354 Jade

YARD	ROLL	2 ROLLS	4 ROLLS
3.58	39.50	38.00	36.50

READY MADE 5/32 VINYL WELT CORD

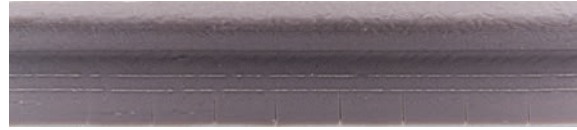

UVR TREATED EXTRUDED 1/2" LIP

EW-18001 Bone White	EW-18018 Brown
EW-18005 Maroon	EW-18020 Dark Green
EW-18006 Bright Red	EW-18021 Dark Grey
EW-18008 Grey	EW-18024 White
EW-18009 Black	EW-18027 Nutmeg
EW-18010 Metallic Blue	EW-18028 Charcoal
EW-18012 Navy	EW-18031 Titanium
EW-18013 Buckskin	EW-18034 Medium Opal

	YARD	ROLL	2 ROLLS	4 ROLLS
100 yard rolls	3.10	110.00	106.00	102.00
REDS	3.10	110.00	106.00	102.00

HIDEM WELT

MARINE GRADE NO-CORD

FLOTILLA COLORS

- 546 HAZE
- 549 CARIBBEAN BLUE
- 550 ENSIGN BLUE
- 554 SNOW WHITE
- 568 STRATO BLUE
- 569 MARINE WHITE

- Mildew treated
- Uv resistant
- -10 Cold crack
- Weight: 32 oz.
- 25 yard rolls

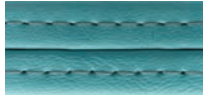

SEAQUEST COLORS

- | | |
|-----------------|-----------|
| AMERICAN BEAUTY | MIDNIGHT |
| AQUA | MIST |
| BUFF | NAVY |
| CHALK | NU TEAL |
| DEEP EMERALD | OYSTER |
| DUNE | PEARL |
| EBONY | PELICAN |
| FOREST | ROYAL |
| HAMPTON | RUBY |
| LEMON | SMOKE |
| LOTION | TEAL |
| MARBLE | WHITE ICE |
| LIGHTHOUSE RED | |

COLOR CARDS AVAILABLE

PER YARD	YARD	25 YDS	50 YDS
	4.36	2.36	2.16

READY MADE 5/32 TINSEL WELT CORD

UVR TREATED EXTRUDED 1/2" LIP

TWO COLORS:
GOLD
SILVER



PER YARD	YARD	10 YD	50 YD	250 YD
	3.18	1.98	1.58	1.18

LISTING

BLACK TYPAR

100 yard rolls

- SEAT COVER WIRE ROD INSERT



	SIZE	ROLL	2 ROLLS	4 ROLLS
PER ROLLS	1"	59.20	56.20	53.20
PER ROLLS	1½"	76.40	73.40	70.40
PER ROLLS	2"	94.00	89.00	86.00

LISTING HEADLINER

WHITE TYPAR - FOLDED

100 YARD ROLLS
3" FOLDED = 1.5" WIDE



PER ROLL	EACH
	80.00

TRUCK SEAT WELT

STYLE: "J" SHAPE
COLOR: BLACK
LENGTHS: 54" STRIP



PER 54" STRIP	EACH	12	24	48
	7.70	6.00	5.50	5.00

LISTING with CORD

BLACK TYPAR



WIDTH	YDS/ROLL	1 ROLLS	2 ROLLS	4 ROLLS
1"	100	76.80	73.80	70.80
1½"	100	92.20	89.20	86.20
2"	100	106.20	103.20	100.20

CARPET BINDING 1 1/4" SINGLE FOLD



close up

CRUSH GRAIN

STOCK: BLACK and WHITE

Color cards available

Colors special ordered

301 RED	318 MAROON	329 ALMOND
302 ROYAL BLUE	320 TAUPE	330 FIRETHORN
306 SADDLE	321 TOBACCO	331 BLUE
308 BLACK	322 GOLD	332 OXBLOOD
309 WHITE	323 GREEN	333 CHARCOAL
310 OFF WHITE	324 CAMEL	350 DK. BROWN
311 DARK GREY	325 DARK BLUE	352 SLATE BLUE
312 LIGHT GREY	326 LIGHT BLUE	353 GRAPHITE
316 TURQUOISE	327 WILLOW	354 JADE

50 YARD ROLLS

ROLL 71.80
4 ROLLS 68.40

JIFFY TRIM

Snap-On-Trim. Vinyl covered wire for finishing panel boards, office furniture, exposed edges. Environmentally safe vinyl. Embossed PVC extrusions with non-cadmium stabilizers.

TYPES REGULAR JUMBO
FITS 1/16" 3/16"



COLORS: BLACK OR WHITE
100 feet per carton

	COLOR	FT/RL	FOOT	ROLL	2 ROLLS	4 ROLLS
REGULAR	Black	100	3.58	158.00	152.00	146.00
REGULAR	White	100	3.90	190.00	184.00	178.00
JUMBO	Either	80	4.04	163.20	158.40	153.60

CARPET NYLON LOOP DYNAMIC



close up

#301 DETROIT BLACK

40" WIDTH
30 YARD ROLLS

30 YARD ROLLS	YARD	10 YDS	30 YDS
	30.60	28.60	27.00

CARPET NYLON CUT PILE

DORSETT
THE PERFORMANCE MILL

Width: 40"
Pile height: 3/8"
Secondary backing: Latex/Poly
Yarn - Wt/5q Yd: 13.50oz
30 yards per roll



close up

#801 BLACK
#851 BISCUIT
#853 METALLIC SILVER
#8070 DARK GRAY
#8275 AGATE GRAY

PER YARD	YARD	10 YDS	30 YDS
	34.20	32.00	27.60

CARPET FASTENER

V23-103



Per Each	EACH	12	50	100
	4.70	4.40	4.14	3.66

HEEL PADS

COLORS:

BLACK
CHARCOAL
SADDLE
BEIGE

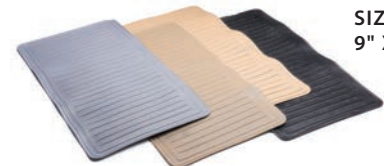

SIZE
9" X 17"

PIECE	EACH	SIX	DOZEN
	6.10	5.30	4.70

SPONGE ROD

WINDLACE



no lip

with lip

	CTN	YARD	BOX	2 BOXES	4 BOXES
1/2" NO LIP	50YD	3.92	96.00	90.00	88.00
1/2" WITH LIP	50YD	4.60	130.00	123.00	120.00
3/8" NO LIP	50FT	-	51.00	45.00	40.60
1/4" NO LIP	50FT	-	42.60	37.50	33.90

SEAT-A-LATORS

SIZE	EACH	5
14" x 16"	21.90	17.50
15" x 17"	23.10	18.60
15 1/4" x 50"	41.30	36.30
14 3/4" x 45"	48.20	42.40
16 3/4" x 52"	42.00	37.00
19" x 52"	43.80	38.50

TRUCK SEAT
SPRINGS
HEAVY GAUGE
Helicals: 2 5/8"
\$2.00/Each

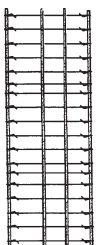
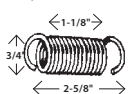

CARPET BACKING

"SNAP" BACK

Non-slip "SNAP-BAC" backing prevents mats from slipping when glued to the back of marine or automotive accessory or throw mats.

CHARACTERISTICS:

- Excellent for making throw mats
- Adds durability to throw mats
- Easy application
- Sound dampening
- Moisture and mildew resistant
- Softer underfoot cushion

SPECIFICS:

- Backing color: Black • Face color: white
- Face content: 00% Polypropylene
- Width: 72"
- Standard weight: 48.5 oz per square yard
- Standard roll length: 33.33 yards



"NIB" BACK

Marine and Automotive

"NIB" BACK

Non-slip "NIB" backing prevents mats from slipping when glued to the back of marine or automotive accessory or throw mats.

CHARACTERISTICS:

- Excellent for making throw mats
- Adds durability to throw mats
- Easy to apply to mats

SPECIFICATIONS:

- Color: Black
- Width: 72"
- Standard weight: 50oz per sq yard
- Standard roll length: 16.6 yards

RECOMMENDED ADHESIVE: PLATINUM WEB SPRAY #150 (on page 104)

	PER YARD	YARD	10 YDS	ROLL
"SNAP" BACK	59.80		598.00	598.00
"NIB" BACK	52.60		526.00	526.00

XTREME SEAL™

XTREME SEAL™ edge seal is the perfect choice as an edge seal on all types of custom covers:

- Convertible tops
- Side curtains
- Camper enclosures
- Windshield tops and sides
- Front-drop windshields
- Radar arches
- Deck seals

Additionally, the unique design and three-point-contact seal of XTREME SEAL™ edge seal is ideal for many common problem areas, such as:

- Windshield wipers
- Grab rails
- Radar arches
- Compound curves and angles



XTREME SEAL™ edge seal is a high-tech extrusion engineered and manufactured with the most advanced E.P.D.M.¹ material available. The profile of XTREME SEAL™ edge seal is a closed-cell, flexible material that can be glued or sewn to most materials and surfaces. The flexibility and unique design of XTREME SEAL™ edge seal creates a three point contact seal on most surfaces.

Imagine the cost savings in labor and materials over vinyl tracking, vinyl welt, Velcro® flaps, and zippers! XTREME SEAL™ edge seal will make your finished product look professional, with superior performance and less hassle to you and your customers.

	PER FOOT	FOOT	100 FT
BLACK	7.02		702.00
WHITE	7.80		780.00

ABS BOARD SP-9010

MEDIUM IMPACT RIGID BOARD - BLACK

TEST	CONDITION	UNITS	VALUE
Tensile strength	ASTM D638	psi	6,000
Elongation (%)	ASTM D638	%	5-25
Flexural strength	ASTM D790	psi	10,000
Hardness	ASTM D785	Rockwell R	105
Flammability rating	MVSS 302		PASS
	UL94 HB		PASS

* 48"x96" is a special order. Allow 3 to 5 working days.

Create custom shapes for
Automobiles • Street Rods • Marine
Experimental Aircraft

- SP-9010 is a medium impact rigid ABS sheet
- Provides good physical properties at an effective price.
- This ABS sheet is light weight and flexible.
- It can be heated, with heat gun, and formed to various angles and shapes.
- You can sew through it and it will hold a staple.
- It can be glued with common PVC plumbing pipe adhesive.

SHEET SIZE	THICKNESS		1			6			12		
	MM	INCHES	1	6	12	1	6	12	1	6	12
48" x 48"	.06	1/16"	40.50	39.50	38.50						
* 48" x 96"	.06	1/16"	81.00	79.00	77.00						

KOMATEX® FLEX BOARD

Komatex Board is a PVC foam which can be heated, re-shaped and vacuum formed to create many different contours.

Make custom door panels, headliners, consoles and console lids, trim panel replacements, tack strips, and many other applications for custom interior work and restoration.

Komatex can be glued (PVC adhesive is recommended), stapled, screwed, painted, punched, routed, sanded, drummed, and sewn.

TIPS:

- When stapling Komatex board, use short wire type staples with a chisel point. The preferred length is 5/32" or 3/16".
- Repair cracks and splits with a PVC adhesive. * Please note: PVC adhesive will expand with the board and not separate!
- It is always best to drill pilot holes for screw fasteners, making the holes slightly larger than the screw size.
- Komatex Board holds up well in all conditions, but will expand in heat and contract when cold.
- Allow for slight expansion and contraction (approximately 1/16"); do not fasten ends tightly; allowing the board to float.

Lightweight and flexible! Be creative!

Self-extinguishing!

KOMATEX Flex Board
PVC FOAM BOARD

SHEET SIZE	PER CASE	1	6	12
1/8"x 48"x 32"	12	37.00	33.00	30.00
1/8"x 48"x 96"	12	104.80	91.60	85.60

POLYESTER TRUNK LINING

Also can be used as speaker fabric!

SPECIFICS:

- Width: 54"
- Weight: 9oz
- Content: Polyester
- 50 yard rolls

- COLORS:**
- BLACK
 - CHARCOAL
 - HEATHER
 - SILVER

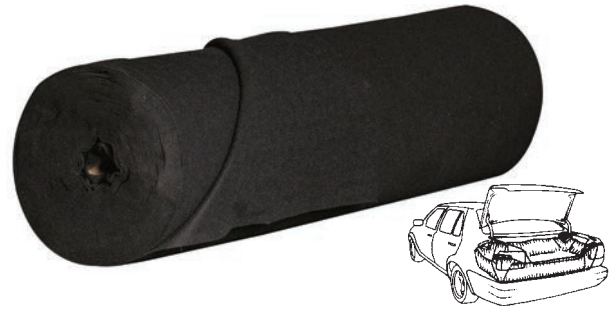

PER YARD	YARD	25 YDS	50 YDS
	19.10	13.60	12.10

READY MADE CARPETS

Call for pricing and availability!

- 7 Original materials
- Easy installation
- Perfect fit
- Over 325 original colors
- Meets or exceeds OEM specifications
- Matching floor mats available

We offer over 15,000 styles to fit vehicles from the 1940s to the present; from cut and sewn for the early models, to precisely molded sets for later models. All are available in their original material and color. No interior restoration project is complete without an ACC carpet.

Sound deadeners, such as carpeting, helps insulate your vehicle from road noise in addition to engine heat. They are available in EVA, foil back, or mastic with jute, and are custom made to fit each model perfectly. ACC sound deadeners meet Federal flammability standards. It is the perfect solution when replacing your carpet and it increases its durability. Two backing choices are available for molded carpet; poly backing is standard for most applications while Mass backing is an excellent upgrade option. Mass backing extends the carpet life while further insulating the interior.



CARPET PADDING

PRODUCT NAME:	SOUNDBLOK 20, 27, 40		
CONSTRUCTION:	100% needle punched, synthetic fibers		
FIBER COLOR:	Gray – slight multicolor		
LAMINATE COLOR:	n/a		
PART NUMBER:	606010	606012	606020
WEIGHT:	20 oz/sy	27 oz/sy	40 oz/sy
THICKNESS:	0.281"	0.344"	0.422"
TENSILE STRENGTH:	41 Lbs.	60 Lbs.	75 Lbs.
R-VALUE:	1.80	2.08	2.20
WIDTH:	36" Standard		
LENGTH:	75'		

TYPE: JUTE
36" WIDTH
25 YARD ROLLS



ATTRIBUTES

- Hypo-allergenic
- Mothproof
- Mildew and odor resistant
- Drapes easily to fit all contours
- MADE IN THE U.S.A.

SOUND ABSORBITION	NRC - ASTM 423-77:	0.66
SOUND ABSORBITION	SAA - ASTM C423-08:	0.34
FLAMMABILITY PILL TEST	DOC-FF-1-70:	Pass
FLAMMABILITY INTERIOR	FMVSS 302:	Pass
SMOKE DENSITY TEST	NBS:	Pass
INDOOR AIR QUALITY TEST	CRI: Green Label Certified	

	YARD	10 YDS	25 YDS
36" X 20 oz.	8.80	7.60	6.60
36" X 27 oz.	11.00	9.80	8.80
36" X 40 oz.	15.00	13.80	12.80

DOOR PANEL BOARD

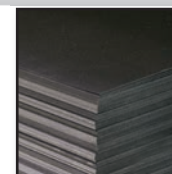
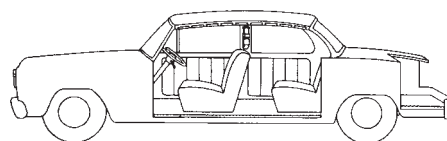

	SIZE	EACH	12	25	50
#9 BLACK COWL BOARDS	39" X 65"	20.90	18.80	17.70	16.60
#7 BLACK WATER PROOF	32" X 48"	19.90	17.90	16.90	15.90
#7 BLACK WATER PROOF	39" X 65"	27.20	25.10	23.90	22.90

TOPLINE PINPOINT 1 1/4" SINGLE FOLD BINDING

GM PINPOINT GRAIN



333 CHARCOAL CRUSH	555 LIGHT TAN	568 SLATE GREY
515 DARK BLUE	558 RED	569 BRIAR BROWN
543 BROWN	559 FIRETHORN	571 OXFORD WHITE
549 BONE WHITE	560 BEIGE/TAN	573 CHARCOAL
552 BLACK	562 BUCKSKIN	576 BURGUNDY
553 BLUE	564 MAROON	580 MEDIUM GREY
	567 SADDLE	

50 YARD ROLLS	YARD 3.48	ROLL 74.00	4 ROLLS 69.00
---------------	--------------	---------------	------------------

TOPLINE PINPOINT 3/4" DOUBLE FOLD BINDING

GM PINPOINT GRAIN



333 CHARCOAL CRUSH	555 LIGHT TAN	568 SLATE GREY
515 DARK BLUE	558 RED	569 BRIAR BROWN
543 BROWN	559 FIRETHORN	571 OXFORD WHITE
549 BONE WHITE	560 BEIGE/TAN	573 CHARCOAL
552 BLACK	562 BUCKSKIN	576 BURGUNDY
553 BLUE	564 MAROON	580 MEDIUM GREY
	567 SADDLE	

50 YARD ROLLS	YARD 3.30	ROLL 65.00	4 ROLLS 60.00
---------------	--------------	---------------	------------------

TOPLINE CRUSH GRAIN 1 1/4" SINGLE FOLD BINDING



949 BLACK	950 OFF WHITE	948 WHITE
-----------	---------------	-----------

50 YARD ROLLS	YARD 3.52	ROLL 76.00	4 ROLLS 71.00
---------------	--------------	---------------	------------------

TOPLINE CRUSH GRAIN 3/4" DOUBLE FOLD BINDING







949 BLACK	950 OFF WHITE	948 WHITE
-----------	---------------	-----------

50 YARD ROLLS	YARD 3.52	ROLL 76.00	4 ROLLS 71.00
---------------	--------------	---------------	------------------

STAYFAST BINDINGS

• BLACK • TAN
• LIGHT NEUTRAL

WIRE ON  25 YDS/RL	HIDEM  25 YDS/RL	BIAS BINDING  3/4" DF 50 YDS/RL	 1 1/4" SF 50 YDS/RL
CUTS PER YD 7.50	PER YD 7.04	PER YD 6.06	PER YD 6.54
ROLLS 5.00	4.54	3.56	4.04

CUSHION SPRING CLIPS

Cloth-lined cushion spring clip to fasten springs to each other or to border wire.

• 7/8" long • For 1/4" or two 8 gauge wires.

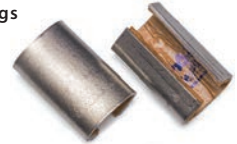

PART# 7707	100/BX 29.90
-------------------	------------------------

TRIM PANEL FASTENERS



#12134
(Chry: 4114785)
Trim Panel Fastener
Zinc

PER 50
34.40



#12671
3/4" Nail
Slips on door panel
fastener strip to
replace broken nails
in panel edging

PER 50
49.90

TRIM CLIPS

Curveco
PRODUCTS



#12069
Upholstery
Clip

PER 50 26.80



#9416
Snap-On Trim Clip
Panel range
.06 - .09"

PER 100 35.70



#9417
Snap-On Trim Clip
Panel range
.105 - .115"

PER 100 29.30



#20345
Headliner Retainer
GMC and K Trucks

PER 25 27.40

BOAT / BOOTH BACK CHRISTMAS TREE FASTENER

PART
#17599



UNIT PKG 25
BOX 23.40

WELT TIP

PART
#7185



Welt Tip/End Tip
Nickel Plated Brass

UNIT PKG 100
BOX 74.80

CUSHION CLIP

PART
#7578



Seat cushion upholstery clip.
Used in repairing drooping
headliners.

UNIT PKG 500
BOX 58.80

DOOR AND PANEL FASTENERS

#1720
• Chrysler
Products



Door
and quarter
trim panel
fastener

PER 100

34.60

#11406
Trim clip
fastener



Head diameter: 1/2"
for 1/4" hole

PER 100

16.40

#808
• Chrysler
Products



Trim panel
fasteners

PER 100

16.40



#2385
• Ford
• Lincoln
• Mercury



Door trim
panel fastener

PER 100

34.60

#10080
• Chrysler



Radiator grille
panel upper
support

PER 100

46.90

#12134
• Chrysler
4114785



Trim panel
fastener

PER 50

34.40

#5961
• Capped Trim
Fastener



1/4" fastener

PER 100

26.80

#10780
• Ford



Door trim
panel fastener

PER 100

33.90

CHRISTMAS TREE FASTENERS



#11678
Trim panel

PER 25 9.90



#11796
Trim panel

PER 50 14.90



#12909
Trim panel

PER 50 16.90



#12759
Trim panel
(McDonald's booths)

PER 25 10.60



#11675
Roof headliner
GM and Chrysler

PER 50 21.20



#11677
Trim panel
retainer
GM and Chrysler

PER 50 25.50



#15461
Trim panel
(GM:363137)

PER 50 18.00



#15479
Trim panel
(Ford: N804349S)

PER 25 16.00



#13467
Firewall insulation
(GM: 7642589)
(AMC: 4001 934)

PER 25 12.60



#12766
Stone Shield
(GM: 22512276)

PER 25 11.00



#12731
Seat back

PER 25 10.30



#14017
Fascia retainer
Ford

PER 25 16.50



#11673
Interior trim
GM

PER 50 18.30



#14032
Trim panel
(GM: 15588078)
(McDonald's booths)

PER 10 11.50



#11671
Seat back panel
(FORD: 387182S)
(AMC: 4001 934)

PER 25 11.50



#14757
Eng. heat shield
(Ford: N804448)

PER 25 19.40



#16818
Trim panel
(GM: 21094146)
(Chry: 6501301)

PER 25 14.30



#12137
Radiator shield
(GM: 1619321)

PER 25 11.10

TRUCK and BOAT BOWS *FIBERGLASS*

	EACH
72" FIBERGLASS	52.30
78" FIBERGLASS	56.50
96" FIBERGLASS	65.10
120" FIBERGLASS	78.90

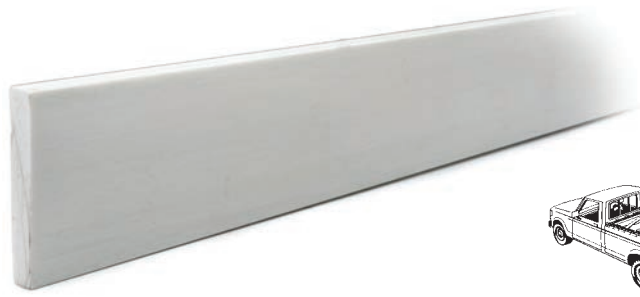

#30 DRILL BITS

Double-ended #30 Drill bits; specifically for 1/8" pop rivets.



12 BITS PER VIAL	VIAL 58.70
------------------	---------------

BOW SOCKETS

Cast Aluminum: Deep



PER SOCKET	EACH 5.40	DOZ 4.90	50 4.20
------------	--------------	-------------	------------

TONNEAU COVER ACCESSORIES

RAILS

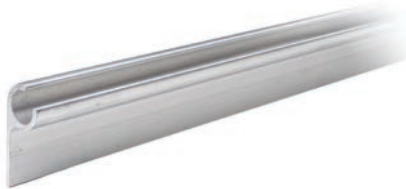

64" Tonneau Rails	EACH 23.60	SIX 22.60	DOZ 21.60
-------------------	---------------	--------------	--------------

INSERT WELT

BLACK or WHITE
100' ROLLS



100' Rolls

	FOOT	ROLL	2 ROLL
BLACK	3.04	104.00	98.00
WHITE	3.08	108.00	102.00

SOFT-SEAT VELCRO and BLACK HOOK CHANNEL

FOR AUTO SEAT COVERS

The Soft Velcro Fabric and Black Hook Soft-Seat Channel are used together to replace the traditional technique of attaching seat covers with hog rings. The fabric attachment is a cheesecloth type fabric that acts as the loop side of Velcro to mate with the black hook soft-seat channel.

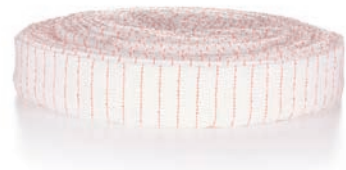

1-5/8" SOFT VELCRO FABRIC	25 YARD ROLL 53.60
1" BLACK HOOK CHANNEL	108.20

STEEL and STAINLESS STEEL HOG RINGS

TYPE	SIZE	GAUGE	PCS/LB	ENDS
Steel	3/4"	14	500	Sharp
Stainless Steel	1/2"	15	575	Blunt



SHARP POINTS



SEA-CLAMPS
BLUNT ENDS

STEEL	PER LB	POUND 7.30	10 LBS 5.10	25 LBS 4.14	50 LBS 3.94
STAINLESS STEEL	PER LB	22.20	19.20	17.42	

ENGEL HOT KNIFE

CUTS AND SEALS THE EDGES OF SYNTHETIC FABRICS TO PREVENT FRAYING.
The knife features a cutting foot that eliminates the need for a special cutting base or surface. Designed for intermittent operation, the knife heats up in six to eight seconds. Temperature is controlled by a convenient trigger switch.



shown complete

C852



C856



C851



STYLE NO.	DESCRIPTION	PRICE
	COMPLETE SET-UP (C851, C852, C856)	1135.30
C851	HSGO Engel 110 Volt Hot Knife	623.40
C852	Blade, Type 100R	145.80
C856	Cutting Foot	366.10

HEADLINER TOOLS

Headliner Tool: Stuffs headlining in channel above doors. Stuffs upholstery & trim edges into tedious places. Blunt edge of blade cannot damage material. Easy to use around curves and near corners.

#7672



27.20

RIGID TUCKING TOOL

For tucking headlining and upholstery around windows and above doors and other hard to reach places. A sturdy tough tool with a slightly curved blade that has finished edges and rounded corners. Comfortable wood handle with eyelet hole through one end.

#13575



80.20

FLEXIBLE TUCKING TOOL

Blade is made of tough flexible plastic. Rounded smooth edges to prevent snagging of fabric. Correct wooden handle. Helps to put in headlining and to reach hard places. Blade measures: 2" x 1-3/8". Overall length: 6 1/2"

#745



43.50

"EDDY" ELECTRIC HEAT TOOL

- **LIGHTWEIGHT**
Weight: 2 3/4 LBS (For extended periods of use with minimum operator fatigue.)
- **TOUGH TOOL**
Built for rugged handling with GE LEXAN housing and parts that are impact resistant and non-conductive.
- **QUICK-CHANGE ELEMENT**
Extends life and carries an exclusive 2-year limited warranty.

Eddy Heat Tool Model #EP-5UL	AVG TEMP	VOLTS	AMPS	EACH
4" Heating Element Kit #A1055	500-750	115	14.0	252.90
				73.50

The choice of most professional trimmers!



for safe, instant flameless heat...

PNEUMATIC HOG RING PLIER

- Increase your productivity
- Top quality construction
- Ideal for automotive trim shops
- 15 Gauge, 3/4" hog ring closes to 1/4"

BOSTITCH

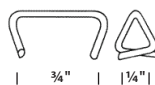

3.3 Lbs



PART	DESCRIPTION	PER BOX	EACH
SR-15	3/4" HOG RINGS (200 50-Ring Sticks)	10M	125.70
TR-201	PNEUMATIC HOG RING GUN	1	1,022.00

HOG-RING PLIERS

- **AUTOMATIC FEED**
- P-7 PLIERS
- P-7 HOG RING STRIPS

BOSTITCH



P-7 PLIERS	EACH
P-7 HOG RINGS (11/16" 2.5m/bx)	99.50
	74.10

MAG DADDY FASTENERS

The Only Universal Magnetic Fastener



UNIVERSAL



CABLE DADDY



ZIP DADDY



LOW-PROFILE



HEAVY DUTY



SPIKE DADDY



GLUE DADDY



GRAND GLUE DADDY



MAX-NUT



STARTER KIT

STARTER KIT CONSISTS OF: 8 UNIVERSAL FASTENERS 4 CABLE-DADDYS 6 ZIP DADDYS
6 LOW-PROFILE MAG-DADDYS 3 GLUE MAG DADDYS 5 HEAVY-DUTY MAG-DADDYS
5 SPIKE-DADDYS 3 MAX-NUTS, 3 GRAND GLUE DADDY

DESCRIPTION	PART NO	EACH	10	20	50
Universal Magnetic Fastener	2972	4.70	4.00	3.80	3.50
Secures cables, wires, brake lines etc, fast	2794	4.70	4.00	3.80	3.50
Powerful magnet with a holder designed for a zip tie. Includes zip ties.	3047	4.70	4.00	3.80	3.50
Designed for a tight fit with limited space.	97603	4.70	4.00	3.80	3.50
A wider more powerful magnet.	97606	5.30	4.60	4.40	4.1
Universal rib-joint fastener for all	3031	2.70	2.00	1.80	1.50
Eliminates the need to drill holes into press board when restoring old vehicles.	97602	5.30	4.60	4.40	4.10
Slightly bigger than the Glue Daddy.	97604	5.30	4.60	4.40	4.10
Fast and strong exterior mounting.	71071	4.10	3.40	3.20	2.90
STARTER KIT	4859	129.40			

"TENAX" FASTENERS

The "TENAX" closure is a highly engineered, self-locking snap fastener that cannot come undone once engaged, yet releases instantly by simply pulling up on the head of the button component.

Manufactured in nickel-over-brass, the "TENAX" products include two styles of studs to accommodate both soft and hard goods applications. While often used in a number of British automotive applications, the uniqueness of the "TENAX" products has generated great interest in the marine industry as well.



31-302 COMBINATION

#11 WOOD SCREW

#34 KEY

	1	20	100
#31/302 COMBINATION	12.60	10.50	9.30
#11 WOOD SCREW	2.90	2.40	2.00
#34 KEY	2.80		

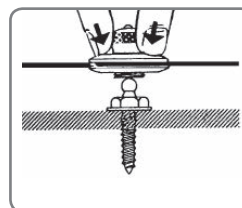

The TENAX safety fastener is easy to lock by pressing the upper part onto the lower part. Ensure the handle cap has

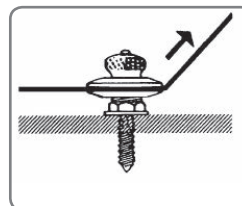

The TENAX safety fastener is not released by forces exerted

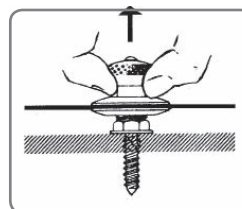

The locking device will not release unless the grip cap is activated, thereby, separating

PHILLIPS OVAL HEAD TAPPING SCREWS



PART #	SIZE	HEAD	100
1799	8 X 3/4"	6	14.70
2710	8 X 3/4"	8	15.40
1483	8 X 1"	6	16.50
2713	8 X 1"	8	17.60
1932	8 X 1 1/2"	6	26.10
2718	8 X 1 1/2"	8	22.20
2633	8 X 2"	8	24.80
2731	10 X 1"	10	20.80
2730	10 X 1"	8	19.20
3070	4 X 1"	4	13.40
2585	10 X 1 1/2"	10	23.70
2665	10 X 2"	10	34.10
1421	8 X 5/8"	8	15.10
2802	6 X 3/8"	6	15.00
3068	4 X 1/2"	4	12.30



WASHERS

NICKEL
ON BRASS



PART#	HEAD	TYPE	100
602	6	FLAT	14.50
604	8	FLAT	15.60
612	4	C/S	19.40
614	6	C/S	20.50
616	8	C/S	25.00
618	10	C/S	34.10

COUNTER SUNK
and
FLAT WASHERS



Flat



Counter Sunk

PHILLIPS OVAL HEAD CHROME PLATED COUNTER SUNK SCREWS



PART #	SIZE	HEAD	100
2771	8 X 5/8"	6	23.00
2751	8 X 3/4"	6	24.30
2772	8 X 1"	6	26.00
2773	8 X 1 1/4"	6	29.70

PHILLIPS OVAL HEAD BLACK COUNTER SUNK SCREWS



PART #	SIZE	HEAD	100
11787	8 x 5/8"	6	18.90
11788	8 x 3/4"	6	18.40
11789	8 x 1"	6	20.80

PART #	SIZE	HEAD	50
11791	10 x 3/4"	8	15.40
11792	10 x 1"	6	16.30

DIMMER SWITCH GROMMET

Top Side
ID: 7/8" OD: 2"

Bottom Side
OD: 2 1/2"



PER EACH 3.78

PHILLIPS WASHER HEAD TAPPING SCREWS



PART #	SIZE	HEAD	50
13709	10 x 3/4"	15/32"	8.70

AUDIO WRAP

FEATURES & BENEFITS

- Audio Vibration Control
- Quieter Ride
- High Heat Resistance
- Butyl Adhesive, Aluminum Faced, Vibration Control Tape
- Maximum performance from your stereo
- Made in the USA
- Premium sound
- Sound deadening tape



TECHNICAL SPECIFICATIONS

- Color: Black
- Thickness: 60 mils ± 5 mils
- Tensile Strength: Pass
- Pliability: Pass
- Permeance: .001 avg.
- In-Service Temperatures: -30°F(-36°C) to 250°F(121°C)
- Acoustic Loss Factor @ Temperature (Using ASTM Method E756@200Hz)
 - .082 @ +14°F(-10°C)
 - .300 @ +86°F(+30°C)
 - .116 @ +32°F(+0°C)
 - .273 @ +104°F(+40°C)
 - .180 @ +50°F(+10°C)
 - .273 @ +122°F(+50°C)
 - .272 @ +68°F(+20°C)
 - .140 @ +140°F(+60°C)
- MVSS-302: PASS
- Temperature Range (Best Performance) 14°F to 140°F (-10°C to 60°C)
- Temperature Range (Resistance) -65°F to 300°F (-54°C to 149°C)

STORAGE, HANDLING AND APPLICATION
Store at room temperature.

DESCRIPTION

Audio Wrap is a self-adhering, 60-mil, high-quality, synthetic butyl rubber adhesive laminated to a heavy-duty, 4-mil Aluminum constraint layer. A siliconized release paper on the adhesive side contributes to the ease of installation. The synthetic butyl rubber adhesive assures superior conformability, excellent low-temperature adhesion and exhibits high temperature flow resistance. The butyl compound adhesive has been tested and proven not to flow at elevated temperatures up to 300°F (149°C).

APPLICATION

Audio Wrap will form a positive and immediate adhesive bond to sheet metal, glass, and wood speaker boxes.

SOUND DEADENING PROPERTIES

The Acoustic loss factor measures sound dampening. The closer to 1, the less vibration. Realistically, any rating over .25 is very significant. Sheet metal alone can measure .001 at 200 Hz. Independent testing concluded that Audio Wrap measured an average of .2465 on 4 testing points, while the best competitor measured on average 30% lower at .1717 on the same test points.

INSTALLATION

- (Always insulate doors first.)
Audio Wrap is specially engineered to stick in an unheated garage. There is no need for heat guns, as with competitors.
1. Remove the interior panel.
 2. Clean the surface removing dirt and oil.
 3. Pre-cut Audio Wrap using paper or cardboard templates.
 4. Remove the release paper and apply directly to the sheet metal. Use of a roller is recommended to reduce air bubbles.
 5. Reinstall the panel to manufacturer's specification.

ROLL SIZE: 15" x 10 Feet EACH
170.60

THERMOZITE 2 SIDED FOIL

*Acoustic and heat resistant liner
For engine compartments*

THERMAL / ACOUSTIC INSULATION:

- Superior sound deflector
- Can be cut with scissors or knife
- Excellent heat barrier
- Can be handle without gloves
- Minimizes vibration
- Contains no irritants or carcinogens
- Lightweight and drapable
- Cost-effective and easy to use solution
- Made in the USA

APPLICATIONS:

- Mass transit vehicles
- Engine hatch covers
- Rv's and Trucks • Hot rods
- Door panels and fire walls
- Machinery enclosures
- Boats and water sport vehicles
- Noisy pipes and valves

PERFORMANCE SPECIFICATIONS:

- Thermal conductivity (K): 0.280
- Thermal resistance (R): 1.3
- Noise reduction co-efficient (Hz): 0.30
- Federal Motor Vehicle Safety Standard 302: Pass
- Made with polyester fiber; not floor sweepings like many others
- Laminated scrim reinforced foil which is available on one or both sides
- Tough aluminum foil provides a radiant heat shield which may increase R values up to a factor of four, depending upon distance from heat source.
- Complies with MVSS-302

SPECIFICS

- Thickness: 1/4"
- Width: 48"
- Yards Per Roll: 25



PER YARD YARD 10 YDS 25 YDS
52.90 47.10 45.50

BLACK POLYESTER FELT WITH PSA BACKING

- Pressure Sensitive Adhesive: Acrylic
- Felt Thickness: 1/16"
- Width: 54"

PER YARD YARD 10 YD 25 YD
60.60 54.60 52.60

AUTOMOTIVE HEADLINING



WIDTH: 60"
THICKNESS: 3/16" Available on ALL Colors.
THICKNESS: 1/8" Available on select colors.
CONTENT: 100% Polyester

Color wall charts available!

	YARD	5 YARDS	10 YARDS
PER YARD	20.10	14.70	14.10



SUEDE HEADLINING

WIDTH: 60"
ROLL LENGTH: 30 yards
THICKNESS: 3/16" (1/8" available on select colors)
CONTENT: Face: 100% Polyester
Back: 100% Polyester
ABRAISON: 30,000 Wyzenbeek (Not recommended for seating)
FLAMMABILITY: FMVSS 302
LIGHTFASTNESS: 40 hour rating

COLORS:
SUE60 ONYX
SUE61 GREY
SUE62 CHARCOAL
SUE63 BEIGE

	YARD	3 YARDS	10 YARDS
PER YARD	34.20	30.20	29.20

ACME AUTO HEADLINERS

- Convertible headliners
- Convertible boots
- Tonneau covers

Call for pricing and availability!



PLASTIC PANE

Distortion free flexible PVC windows!

Kal-Glas®

Kal-Glas® PVC press polished sheets were developed for automotive convertible top windows and face shields.

- Kal-Glas® - 0.040" clear meets AS-6 and Mil Spec. P18080A requirements
- Kal-Glas® - U.V. stabilizers added to enhance longevity and clarity
- Kal-Glas® - is RF weldable, bondable and sewable



	EACH	6	12
24 x 54 x .040	72.60	67.60	62.60
27 x 62 x .040	79.90	74.90	69.90

CONVERTIBLE TOP WEBBING

FOR LATE MODEL CARS:

- LE BARONS
- MUSTANGS
- GENERAL MOTORS



BLACK HERRINGBONE

WIDTH	YARD
4"	12.90
6"	15.10
9"	17.60

RAGG TOPP

CLEANER and PROTECTANT

CLEANER:

- Exclusively formulated for fabrics and vinyl
- Safely removes tough roof soils and some stains
- Will not harm metal, plastic, rubber or wood finishes
- Anti-oxidant • Low ph • No bleach formula
- Leaves no residue • Non-toxic
- Environmentally friendly and biodegradable

PROTECTANT:

- Oem patented formula protection
- Renews and extends the life of fabric topping
- Professional strength formulation without silicone
- Uv protection with uv blocker from ciba
- Restores water and stain repellency
- VOC compliant



	EACH	SIX	DOZ
FABRIC and VINYL CLEANER: 16oz	23.90	21.90	18.90
FABRIC PROTECTANT: 14oz	35.90	33.90	30.80
VINYLY PROTECTANT: 16oz	30.50	28.50	25.50

CONVERTIBLE TOP PADS

- Water repellent
- Mildew proof
- Foam insert



BLACK TOP PADS	PER SET
	45.70

CONVERTIBLE TOP TACK STRIP

50 FOOT COILS



	FOOT	COIL	2 COILS
FRONT 5/8" X 1/8"	3.60	80.00	70.00
REAR 1/2" X 3/8"	3.60	80.00	70.00

WIRE ON

CRUSH GRAIN: BLACK
CRUSH GRAIN: WHITE
PINPOINT GRAIN: BLACK
PINPOINT GRAIN: WHITE

SIZE: 5/8" x 25 yard rolls

Pinpoint grain colors available special order



	YARD	ROLL
25 YARD ROLLS	5.62	90.50

CONVERTIBLE AUTO TOPS



*Popular
Models
Stocked.*



EZON AUTO TOPS®



*Call for
Availability On
Non Inventoried
Models.*



READY MADE VINYL LANDAU TOPS

DOUBLE SEAM UNIVERSAL LANAU TOPS: ELK	189.00
DOUBLE SEAM UNIVERSAL LANAU TOPS: LEVANT	189.00
CENTER SEAM UNIVERSAL LANDAU TOPS: ELK	189.00
CENTER SEAM UNIVERSAL LANDAU TOPS: LEVANT	189.00

BY SPECIAL ORDER: CORSICA, VALINO and TUXEDO GRAINS

BY SPECIAL ORDER: OEM FITTED TOPS



VINYL LANDAU TOPPING *ELK GRAIN*

MEETS OEM STANDARDS:

- Weatherability
- Color fastness
- Stability

SPECIFICS:

- Width: 49"
- Elk Grain
- PVC outer layer
- Polyester fleece backing

QUALITY VINYL FOR:

- Limousine
- Landau
- Special interest
- Formal roof treatment
- Replacement
- Restoration

HAARTZ

- S9753 BRITE WHITE ELK *Padded*
- S848 BLACK ELK *Padded*
- S828 BUCKSKIN ELK *Padded*
- S7384 AUTUMN MAPLEELK *Padded*
- S7693 DARK ROYAL BLUE ELK *Padded*
- S7781 SILVER ELK *Padded*
- S7782 GUNMETAL ELK *Padded*

COLORS	YARD	10 YDS	25 YDS	50 YDS
WHITE	27.20	26.20	24.70	22.70
BLACK	24.30	22.30	21.80	19.80
	23.90	22.90	21.40	19.40

CONVERTIBLE TOP CABLES



GENERAL MOTORS

1966 - 1967 G.M. "A" BODY CABLES 90.10
 • Buick GranSport • Skylark • Chevelle
 • Malibu • Olds F85 • Cutlass 442
 • Pontiac Lemans • GTO • Tempest

1965 - 1970 G.M. "B" BODY CABLES 90.10
 • Buick LeSabre • Wildcat • Chevy Impala
 • Supersport • Olds 88 • Delta • Starfire
 • Pontiac Bonneville • Catalina • Grand Prix
 • Parisienne Supersport

1965 - 1970 G.M. "C" BODY CABLES 90.10
 • Buick Electra • Cadillacs • Olds 98

1972 - 1976 G.M. Full Size 83.30
 • Chevy • Pontiac • Olds • Cadillac

1968 - 1972 G.M. Mid Size 66.70
 • Skylark • Buick • Chevelle • Malibu
 • F-85 Cutlass • Tempest • GTO • Lemans

1984 - 1987 CAVALIER • SUNBIRD 76.70
 Main Tension Cable (fits both cars)

1988 - 1981 CAVALIER • SUNBIRD 76.70
 Main Tension Cable (fits both cars)

1984 - 1991 CAVALIER • SUNBIRD 76.70
 Rear Flap Cable

FORD

1983 - 1988 MUSTANG 60.90

1989 - 1990 MUSTANG 60.90

Late 1990's early 1991 MUSTANG 60.90

1991 - 1993 MUSTANG 60.90

1984 - 1986 LEBARON 60.90

1987 - 1991 LEBARON 60.90

VOLKSWAGEN

1956 - 1979 BEETLE 30.00

1957 - 1974 GHIA

All years CABRIOLET • RABBIT

1967 - 1979 VOLKSWAGEN 53.30

Rear Top Base Tension Cable
 Machine Screw / Nut

1980 - 1993 CABRIOLET • RABBIT 130.10

Rear Tension Cable
 Machine Screw / Nut
 Tension Cable Rod

UNIVERSAL

Universal Adjustable Side Tension Cable 41.40

Fits most makes and models
 • Fiat • Alfa Romeo • etc.

HAARTZ CONVERTIBLE TOPPING



FINISHES and TREATMENTS:

- Soil resistant
- Water repellent • Shrink resistant

SPECIFICS:

- Width: 54" • Standard weight
- GM Grain • Single texture • Sateen back



COLORS

- White / Black
- Beige / Beige
- Black / Black

White/Black, Black/Black
 Beige/Beige

	YARD	10 YDS	25 YDS	50 YDS
White/Black, Black/Black	37.60	35.60	34.60	33.60
Beige/Beige	39.50	37.50	36.50	35.50

HAARTZ STAY FAST Antique Convertible

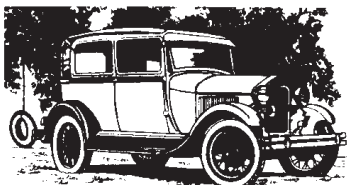

SPECIFICS:

- Width: 60"



COLORS

- Black / Black
- Beige / Beige
- Lt Neutral / Tan

Width: 60"	YARD	10 YDS	50 YDS
	111.40	107.40	101.40

ORIGINAL AUTOMOTIVE LEATHER

- Ford grains and colors
- General Motors grains and colors
- Chrysler grains and colors
- Import grains and colors
- Perforated styles available on all grains and colors

All leather manufactured by a ISO 9001 certified tannery to meet or exceed all O.E.M. specifications.

LEATHER SPECIFICATIONS:

- **THICKNESS:** ASTM D18131.0-1.2 mm
- **WEIGHT:** ASTM D3776 2.5 Oz./Sq. Ft.
- **SIZE:** 45-48 Sq. Ft. Avg.
- **ABRASION:** ASTM D3884 Weight 500g (Taber 5130) Wheels H-18 cycles 300
- **COLOR CROCK:** AATCC-8 Weight 4 lbs. (Crockmeter CM-5) Wet/Dry rub 10 cycles AATCC rating 4 minimum
- **FLAMMABILITY:** FMVSS-302
- **FLEX ASTM D2097:** 20,000 cycles
- **LIGHTFASTNESS:** 200 hours SAE 11885 AATCC rating 4 minimum
- **LIGHT COMPATIBILITY:** D65 daylight with UV (Data color) CWF (cool white fluor.) A tungsten light

SPECIAL ORDER PROGRAM

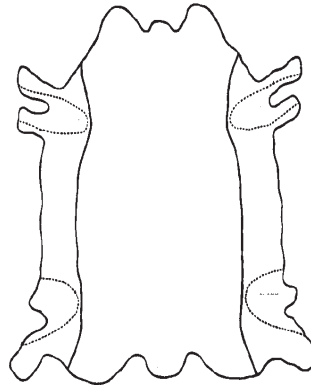

54" FABRIC YARDS	LEATHER SQUARE FEET
1	= 18
2	= 36
3	= 54
4	= 72
5	= 90
6	= 108
7	= 126
8	= 144
9	= 162
10	= 180

Plain Leather

FULL HIDE	HALF HIDE	CUT LEATHER
13.40	15.40	.60

Perforated Leather

Ford Mini	17.80	19.80	.96
Euro	17.80	19.80	.96
Ford Std, GM Small, Mezzo	17.00	19.00	.96
Chrysler Std, GM Std	17.00	19.00	.96
Chrysler Tri-Star	17.80	19.00	.96
GM Mini, GM Micro	18.70	20.70	.96

PERFORATING

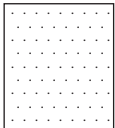

PERFORATING

Leather hides and vinyl yardage can be perforated to a multitude of patterns.

- Chrysler and GM standard perf
- Ford standard
- Ford mini perforate
- Euro perf
- Chrysler tri-star perf.
- GM mini perforate

DESCRIPTION	TYPE	SQ FT
½ Hides	Ford Std, GM Std, GSP	5.90
½ Hides	GEP, GTP, GMP	6.50
½ Hides	GMCR	7.50
Vinyl	All Types - Per Lineal Yard	PER YD 90.00

DETROIT BOOK ORIGINALS

ORIGINAL AUTOMOTIVE INTERIOR TRIM . . .
THE INDUSTRY STANDARD

The Detroit Book is a compilation of information and samples for the automobile industry, including the most comprehensive inventories of fabrics, vinyls, leather and headliners, in the nation.

The Detroit Book is published annually as a convenient tool for our customers giving them the ability to match interiors at their own site.



- Original auto leathers
- Original body cloths
- Original headliners
- Original vinyls

BODY CLOTH	PER YD 59.00
BODY CLOTH 10YRS+	79.90
VINYL	37.90
HEADLINER	33.90

Call for firm pricing on most styles!

SHOCK CORD

MARINE GRADE NYLON

COLOR: BLACK AND WHITE
ROLLS LENGTH: 100 FEET
PRICED PER FOOT



	FOOT	ROLL	2 ROLLS
3/16"	2.10	.60	.53
1/4"	2.20	.64	.57
5/16"	2.40	.84	.74

WIRE SNAP

#142A ZINC PLATED STEEL



EYE	LENGTH	EACH	25	100
1/2"	1 3/4"	1.72	1.22	1.02
1"	2"	1.60	1.10	.90
1 1/2"	2"	5.12	4.62	4.42

SHOCK CORD

TYPE: POLYPROPYLENE
COLOR: SOLID BLACK
ROLLS LENGTH: 100 FEET
PRICED PER ROLL



	ROLL	2 ROLLS
1/8"	50.90	43.30
3/16"	63.60	54.40
1/4"	67.90	57.70

D RING

#563 RUGGEDLY MADE OF STEEL WIRE
NICKEL PLATED



EYE	EACH	25	100
3/4"	1.04	.54	.34
1"	1.26	.76	.56
1 1/2"	1.42	.92	.72

SHOCK CORD HOOK and ADJUSTER HOOK



	EACH	25	50
1/4" HOOK	3.30	2.80	2.10
ADJUSTER HOOK	3.20	2.70	2.20

BUCKLES

- Tongueless buckles for webbing
- dependable and sturdy buckles a firm locking toothed slide.
- Made of the finest grade stamped steel
- ZINC PLATED



SIZE	No.	EACH	25	100
1"	#635	2.26	1.76	1.56
1 1/2"	#635	4.48	3.98	3.78
2"	#5270	5.12	4.62	4.42

ELASTIC LIGHT WEIGHT

COLORS: WHITE & BLACK
WIDTHS: 1/2", 3/4", 1"
SPOOLS: 100 YARDS



WIDTH	WHITE	BLACK
1/2"	93.90	108.90
3/4"	116.40	120.10
1"	157.70	161.40

ADJUSTER BUCKLE

1" SINGLE BAR BUCKLE TO
ADJUST 1" STRAP
FLAT BLACK FINISH



SIZE	No.	EACH	25	100
1"	#146	3.74	3.24	3.04

ELASTIC HEAVY WEIGHT

HEAVY SHOE GORE
COLORS: BLACK, ECRU
WIDTHS: 1/2", 1"

STRONG TO HOLD ON
TIRE COVERS



PART	WIDTH	YDS/RL	YARD	ROLL	4 ROLLS
#500	1/2"	100	3.90	2.70	2.40
#500	1"	36	4.70	3.50	3.20

BUCKLES

- Buckles for nylon webbing
- 1-inch non-slip buckle
- Provides a positive hold when webbing is threaded through the buckle.



PART#	EACH	25	100
4042	1.88	1.38	1.18

SIDE RELEASE BUCKLES

**P-006
BLACK DELRIN**



	EACH	25	100
PER EACH: 1"	2.44	2.24	2.04
PER EACH: 1½"	3.36	3.16	2.96
PER EACH: 2"	4.34	4.14	3.94

SQUARE RING

**P-001
BLACK DELRIN**



LOOP LOC

	EACH	25	100
PER EACH: 1"	.84	.64	.44
PER EACH: 1½"	1.00	.80	.60
PER EACH: 2"	1.14	.94	.74

CAM PRESS BUCKLES

**P-013
BLACK DELRIN**



	EACH	25	100
PER EACH: 1"	2.80	2.60	2.40
PER EACH: 1½"	3.94	3.74	3.54
PER EACH: 2"	3.66	3.46	3.26

D- RING

**P-002
BLACK DELRIN**



	EACH	25	100
PER EACH: 1"	.86	.66	.46
PER EACH: 1½"	1.00	.80	.60
PER EACH: 2"	1.16	.96	.76

TRI-GLIDE

**P-003
BLACK DELRIN**



	EACH	25	100
PER EACH: ¾"	.84	.64	.44
PER EACH: 1"	.86	.66	.46
PER EACH: 1½"	1.14	.94	.74
PER EACH: 2"	1.36	1.16	.96

POLYESTER WEBBING

APPROXIMATELY 100 YARD ROLLS
MORE WEBBINGS ON PAGES 77-79.



PART#	BREAK STRENGTH
#4056	180 LBS
#7624	6,000 LBS

		YARD	100 YD	200 YD
½"	WHITE	4056	2.36	.60
½"	BLACK	4056	2.62	.78
2"	BLACK	7624	4.32	2.32

SNAPHOOK

INTERLOCKING BLACK
DELRIN SNAPHOOK



	EACH	25	100
PER EACH: 1"	1.10	.90	.70
PER EACH: 1½"	1.14	.94	.74
PER EACH: 2"	1.20	1.00	.80

POLYPROPYLENE WEBBING



#7166 - APPROXIMATELY 100 YARD ROLLS
MORE WEBBINGS ON PAGES 77-79.

		BREAK STRENGTH	YARD	100 YDS	200 YDS
1"	WHITE	540 LB	2.14	.48	.44
1"	BLACK	540 LB	2.14	.48	.44
1½"	WHITE	780 LB	2.52	.78	.68
1½"	BLACK	780 LB	2.52	.78	.68
2"	WHITE	1104 LB	2.76	1.02	.90
2"	BLACK	1104 LB	2.76	1.02	.90

NYLON WEBBING



PART#	BREAK STRENGTH
#7207	1,400 LBS
#7270	3,000 LBS

APPROXIMATELY 100 YARD ROLLS

			YARD	100 YDS	200 YDSH
1"	WHITE	7207	4.12	2.12	1.92
1"	BLACK	7207	4.12	2.12	1.92
2"	WHITE	7270	8.04	6.04	5.84
2"	BLACK	7270	5.90	3.90	3.70
2"	BLACK	N0087	5.32	4.12	3.62

SEM VINYL COATING PRODUCTS

CLASSIC COAT

- OEM matched colors
- Excellent for leather and vinyl
- Convenient aerosol package
- Superior adhesion and flexibility
- Multidirectional fan spray
- 34 Colors

MARINE VINYL COAT

- Flexible Coating For Restoring Vinyl Seats
- Improved UV Resistance
- Matches OEM Marine Colors
- Smooth Consistent Finish, Hides Stains.
- 25 Colors

COLOR COAT

- Industry Standard for Vinyl & Plastic Restoration
- Fade Resistant, Flexible Permanent Coating
- Over 50 Colors



The Right Choice



DESCRIPTION	CAN	6 ASRT	CASE(6)
Classic Coat	41.40	37.30	35.40
Color Coat	38.70	34.80	33.10
Marine Vinyl Coat	42.60	38.30	36.40
Marine Engine Colors	31.70	28.50	27.10
Vinyl Prep	39.70	35.80	34.00
Plastic & Leather Prep	39.70	35.80	34.00
XXX Adhesion Promoter	49.20	44.30	42.10
Tack Free	40.00	36.00	34.20
Sand Free	41.10	37.00	35.10
SEM Soap	38.80	35.00	33.20
XXX Gun Cleaner	43.00	38.70	36.80
Trim Black Paint	36.00	32.40	30.80

GRILLE-TEX

Automotive audio speaker cloth 100% polyester

SPECIFICS:

- Width: 68"
- Roll length: 50-55 yards
- Cal. TB #117 Sec E: Pass
- MVSS302: Pass
- Colorfastness to light: Class 5 40 hours
- Colorfastness to crocking: Wet Class 5 Dry Class 5
- Abrasion: heavy duty

COLORS:
CHARCOAL
PEBBLE
BLACK



PER YARD	YARD	10 YARD	25 YD RLS	50 YD RLS
	14.40	12.40	11.70	11.10

BLACK TUNNEL TIES

3/4" Binding tape integrated with draw string

ALLOWS FOR DRAW STRING CLOSURE OF:

- Auto seats
- Machine covers
- Bags

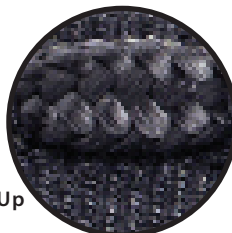

Close Up



BLACK TUNNEL TIES	50' ROLL	150' ROLL	1,200' ROLL
	25.00	52.00	216.00

NEOLINE POLYESTER CORD

Free samples available.

Neoline cordage offers a high performance for an economical price. Neoline polyester knitted jacket and polypropylene core offer superior abrasion and UV protection. The feel is soft and still has low stretch characteristics.

APPLICATIONS:

- Marine
- Awning
- General industrial



SIZE	DIA	TENSILE STRENGTH	FT/RL	ROLL
#4	1/8"	220	500	63.10
#5	5/32"	370	1000	148.40
#6	3/16"	460	500	113.90
#8	1/4"	750	500	174.50

RESISTS:

- Rot
- Mildew
- Many chemicals

BRAIDED POLYESTER ROPE - 1/4"

- 16 BRAID POLYESTER WITH PARALLEL CORD
- LOW STRETCH
- UV RESISTANT
- BREAKING STRENGTH OF 1,100LBS
- DOESN'T ABSORB WATER, SO IT DOESN'T ROT OVER TIME



BRAIDED ROPE	FEET/SPOOL	PER SPOOL
	500	92.00

ALUMINUM "ADJUSTA" TOP BOAT FRAMES

These boat top kits are made with 7/8" .058 aluminum tubing pre-bent and cut into six pieces. Two crown and four outside corners (primary bends), two are tall and two are short. Four sleeves are provided for easy assembly.

INCLUDED HARDWARE:

- Premium grade marine anodized bright dipped aluminum tubing, .058" thickness, 7/8" outside diameter
- Hardware: Chrome die cast

KIT INCLUDES:

- 2 Eye pads
- 4 Outside eye ends
- 2 Jawslides
- 4 Buckles
- 2 Spring straps
- 2 Mounts
- 4 Connecting tubes

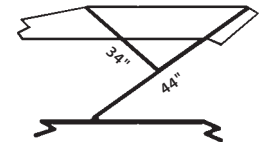

80" Wide

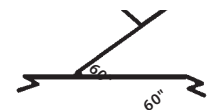

96" Wide

	EACH	6
44" HIGH X 84" WIDE	321.40	301.30
60" HIGH X 96" WIDE	350.30	328.40
Connecting Tubes	2.40	
Collars	4.10	

TENT POLES ANODIZED

These telescoping cam lock support poles have die cast collars and stainless steel components, allowing them to hold a staggering 170 lbs. The aluminum tubing is light weight, anodized, and heat treated to make sure it can withstand any climate, and with the added strength of a ribbed profile this pole is designed to last. The optional swivel pad base is a great way to protect your floor from indents or marring.



optional swivel pad attachment

SIZE	RANGE	EACH	6	12
28" POLE	19"-28"	21.30	19.20	17.80
47" POLE	28"-47"	21.80	19.70	18.30
59" POLE	34"-59"	22.40	20.20	18.80
70" POLE	39"-70"	22.80	20.60	19.10
SWIVEL PAD	N/A	17.00	15.30	14.20

TIE-DOWN RATCHETS



The standard 1/4" ratchet has quick-release thumb trigger and will fit all 1/4" rope (page 237). Working load limit of 150 lbs.



The 1/4" QUICKIE has a built-in ratchet for quick & convenient rope tensioning. Will fit all 1/4" rope (page 237). Working load limit of 225 lbs.



The 1/8" ratchet is compact, easy to use, and virtually unbreakable. Will fit 1/8" rope (Neoline, page 237). Working load limit of 150 lbs.

	EACH	6	12
1/4" QUICKIE	26.00	23.40	21.80
1/4" RATCHET	14.40	13.00	12.10
1/8" RATCHET	10.40	9.40	8.70

BOAT VENTS

BOAT VENT III

- Supports your cover in rain, snow, and ice.
- Provides evenly distributed ventilation along the entire underside of the mooring cover
- Provides a higher volume of airflow per square foot of cover
- Design maximizes airflow across the entire underside of the mooring cover
- Changes in wind direction have no significant effect on vent performance

BLACK	EACH	12	24
	20.40	18.40	17.40



*newly designed teeth
for an extra hold on fabric*

BOAT VENT II

- Supports your cover in rain, snow, and ice.
- Provides evenly distributed ventilation along the entire underside of the mooring cover
- Provides a higher volume of airflow per square foot of cover
- Design maximizes airflow across the entire underside of the mooring cover
- Changes in wind direction have no significant effect on vent performance

BLACK	EACH	12	24
	18.50	16.50	15.50
WHITE	23.60	21.60	20.60



BOAT VENT AERO

Boat Vent AERO is Vico Marine's first sew-in vent. Great to use where tenting with the Boat Vent 2 or 3 may not be an option (i.e. cock pit cover). The louver front can be used to help prevent bees or rodents from entering the cover or just extra protection from heavy rain. For maximum venting or use with the traditional cone look, you can also install without the front. (sold separately)

- Available in soft rubber or harder HDPE
- White or Black options
- Optional louver front to help protect against bees or rodents

BLACK	EACH	6	12
	8.00	7.20	6.70
WHITE	8.00	7.20	6.70



SOFT RUBBER



HARD PLASTIC

SHRINK VENT

- New two-sided, sharper self-piercing teeth
- Pre-installed weather resistant adhesive to stick directly on shrink wrap cover
- Easy to use 2-piece design
- Simply push down and twist

BLACK	EACH	6	12
	6.00	5.40	5.10



AUTOMOTIVE • FURNITURE • MARINE

VINYL SUMMARY GUIDE ON PAGES 164-167



Abbey Fabric.....	213
ABS Board	224
Accord	83
Acme Auto Headliner	233
Acrylic Binding	158
Active Dac	62
Acu-Cutter.....	146
Adhesives.....	100-105
Adhesives: Cyano Acrylate	104
Adhesives: Guide.....	105
Adhesives: Landau Top/Trim	102
Adhesives: Quickwood Epoxy	104
Adhesives: Vinyl Repair	103
Adhesives: Water Based	101
Adjustable Boat Frames	241
Advantage Vinyl.....	156
Aircraft Foam	34, 41
Aircraft Leather	211
Allante (Morbern)	201
Allegro (Spradling).....	170
AllSport (Morbern)	202
Allure (Naugahyde)	200
Alpin Leather.....	210
Aluminum Zippers	76
Amann Thread	72
Animal Hair	89
Antimicrobial Foam	32-33
Antimicrobial Vinyl.....	201
Antique Casters	98
Antique Nail Remover	120
Antique Nails (Brass)	122
Apex (Spradling)	170
Aqualon Boat Topping.....	161
AquaSnaps	220
Aqua-Tite	109
Aries (Spradling)	170
Armada (Enduratex)	184

Aspirations (Enduratex)	184
Atmosphere (Spradling)	170
Audio Wrap	232
Auto Ripper	144
Automotive Carpet	223
Automotive Headliner	233
Automotive Vinyl (Enduratex).....	195
Au-Ve-Co Parts.....	226-227, 231
Awls	140



B8P Bostitch Hand Stapler.....	114
Bags: Plastic.....	149
Bands: Springs.....	92
Bantam Ripper	144
Bantex Banner Vinyl.....	153
Basketball Pillows.....	89
Batting.....	61-65, 69
BeA Staples	110-112
Bean Bag Fill	44
Beluga (Spradling)	171
Berry Staple Puller	139
Berwick Tweed (Enduratex)	185
Beveled Foam Shapes	53
Billiard Cloth	154
Binding: Acrylic	158
Binding: Auto	226
Binding: Carpet	223
Binding: Twill Tape.....	79
BioBred Foam	60
Black Vinyl Reference	205
Blo-Gun	141
Boat Bows	228
Boat Canvas.....	160-161
Boat Frames	241
Boat Top Poles	241
Boat Vents	242
Boat Windows.....	163

Bobbins: Metal	149
Bobbins: Nylon	71
Bobbins: Polyester	73
Bolster Pillow Forms.....	88
Boltaflex Collection Guide.....	166
Bonded Fiberfill.....	64-65
Bonded Foam	36-37
Bow Sockets	228
Bows	228
Brads.....	115
Brass Buttons	126
British Sterling (Enduratex).....	185
Brushed Alum. (Enduratex)....	185, 195
Bubble Wrap.....	50
Buckles.....	238-239
Buckskin (Spradling)	171
Buffed Foam Shapes	53
Bun Feet	129-130
Burlap: Jute	82
Burlap: Sagless	82
Burlap: Synthetic	82
Button Cutters.....	127
Button Dies	127
Button Drills.....	127
Button Machines.....	127
Button Molds.....	124-125
Button Molds.....	124-126
Button Plugs	144
Button Service.....	123
Button Twine.....	75
Button Washers	126
Buttons	123-127
BW Clip Pliers	138
BW Clips.....	90



C Clips.....	90
CA Adhesive.....	104

AUTOMOTIVE • FURNITURE • MARINE

VINYL SUMMARY GUIDE ON PAGES 164-167



Cables for Convertibles	236
Cam Press Buckles	239
Cambric	83, 85
Caning	150
Cantina (Culp).....	196
Canvas	152-161
Canvas Treatment	109
Capitano (Nautolex)	200
Caprice (Spradling).....	171
Car Cover.....	155
Carbon Fiber (Enduratex)	186, 195
Carbon Fiber (Spradling)	171
Cardboard Tacking Strip	117
Carpet	162, 223
Carpet Adhesive	102
Carpet Backing	224
Carpet Binding	223
Carpet Fastener	223
Carpet Padding: Jute	225
Carpet Padding: ReBond Foam	39
Carpet: Automotive	223
Casters	96-99
Castillo (Culp)	196
Cel-U-Flex	87
Cenery (Spradling)	172
Chain Maille (Enduratex).....	186
Chair Duck.....	153
Chalk.....	145
Chamea II (Naugahyde).....	201
Channel Vinyl (Nassimi)	180
Channeled Foam	40, 172, 180
Charm.....	213
Chennile	213
China Pencils	145
Chipboard	116, 150

Christmas Tree Fasteners.....	227
Clear Vinyl: Auto/Marine	163
Clear Vinyl: Furniture Covers.....	86
ClearOn Monofilament Thread	72
Clip-On Edging.....	87
Clips	77, 90-91
Clips: Panels	148
Closed-Cell Foam.....	41, 43
Clothbacked Foam	40
Coastal Ranch (Enduratex).....	186
Colorguard (Boltaflex)	198
Combustion Modified Foam	34
Comforel (UltraSoft).....	66
Comfort-Tick.....	154
Common Sense Fasteners	217
Confor Foam	43
Connecting Links/Tubes	92
Consew Cutter	146
Conso Gimp	151
Contact Adhesive	102
Contessa	208
Contrast Thread (Top Stitch)	74
Convertible Auto Tops	235
Convertible Tack Strip.....	234
Convertible Top Cables.....	236
Convertible Top Fabric	236
Convertible Top Pads	234
Convertible Top Webbing	234
Convertible Windows	234
Cordura	154
Corinthian (Enduratex)	195
Corinthian (Spradling)	172
Cotton Batting.....	69
Cotton Duck.....	152-153
Cotton Tape	79
Cotton Weltcord (Braided).....	80
Counterpane (Enduratex)	187
Cowl Board	225
Crazy Glue	104
Crianza (Enduratex).....	187
Crinol	83

Culp Collection Guide.....	166
Curved Needles	137
Cushion Eze	82
Cushion Hooks	144
Cushion Stuffer Machine	147
Cushion Wrap Guide.....	61
Cut to Length Zippers	216
Cutters: Button.....	127
Cutters: Foam	146
Cutters: No Sag	92
Cutters: Wire	138
Cypress Laquer/Stains.....	134



D Rings	144, 238-239
Dacron.....	61-67
Dap Spray Adhesive	100
Dap Weldwood.....	100, 102
Decking: Denim.....	84
Decking: Hide-A-Bed.....	95
Decorative Nail Gun.....	120
Decorative Nail Tools	120
Decorative Nails.....	118-122
De-Greaser	108
Detroit Books	237
Dies.....	126-127, 220-221
Dillon (Culp)	196
Dimensions (CMI)	201
Dimmer Switch Grommet	231
Doeskin (Enduratex)	195
Dolce (Spradling)	209
Door Panel Boards.....	225
Door Panel Fasteners	227
Dorsett Carpet	223
Dowel Screws.....	133
Down.....	89
Down Pillows.....	89
Down: Synthetic.....	66

AUTOMOTIVE • FURNITURE • MARINE

VINYL SUMMARY GUIDE ON PAGES 164-167

Downproof Ticking	85
Drapery Grommets	123
Drapery Lining	86
Drawstring Binding	240
Dressmaker Pins	137
DriFast Foam	32-33
Drill Bits	228
Dual-Lock System (3M)	215
Duck Bill Pliers	138
Duo-Fast Staples	110-112
DuPont Dac	62-63
Durable Dot Dies	220
Durable Snap Fasteners	218-220
Dura-Snap Fasteners	126
Durasnaps	126, 220
Dust Covers	83, 85



Eclipse (Enduralex)	195
Economy Roll Edge	87
Edge Roll	87
Edge Seal	224
Edgewire	91
Edgewire Clips	90
EK Clips	91
EK Nails	91
El Capitan (Enduralex)	187
Elastic	144, 238
Elastic Webbing	77
Electric Staple Gun	114
Embossed Leathers	211
Endurasoft Auto (Enduralex)	195
Enduralex Collection Guide	165
Engel Hot Knife	229
Epoxy Cement	103
Ester Foam	51
Etha Foam	51
Euroglaze Leather	210

Extreme Seal	224
Extreme Seating	203
EZ Vinyl (Spradling)	204



Fabric Chart	254-255
Fabric Cleaner	108
Fabric Cutter	142
Fabric Guard	109
Fabric Protector	109
Fabric: Automotive	211-213
Fabric: Contract	212
Fasco Staples	110-112
Fast Tack 92 Adhesive	100
Fasteners	217-220, 223, 227, 230
Faux Leather	206-209
Faux Leather Collection Guide	167
Faux Suede	213
Feather-Proof Ticking	85
Felt Glides	133
Felt w/ PSA Backing	232
Ferrules	92
Fiber Core	68
Fiber Weltcord (Braided)	80
Fiber: Bonded	64-65
Fiber: Fill	63
Fiber: Reference	61
Fiber: Sewn	62
Fiber: Smooth Bond	64
Fiberglass Bows	228
Fiberglass Screening	155
Filler Bazooka	141
Finesse Leather	210
Finished Nails	118-122
Firegard (Fabric)	84
Fish Shanty Canvas	154
Flex Pad	67
Flex-Trim	117

Flotation Foam	33
Flotilla (Spradling)	172
FLW Propex	82
Foam Drills	147
Foam Rolls: Arm&Rail Pads	38
Foam Rolls: Clothback	40
Foam Sheets: Aircraft	34, 41
Foam Sheets: Good Quality	18-23
Foam Sheets: Better Quality	24-25
Foam Sheets: Best Quality	26-31
Foam Sheets: Gel	44
Foam Sheets: Latex	35
Foam Sheets: Marine	32-33
Foam Sheets: ReBond	36-37
Foam Sheets: Ultra-High Density	39
Foam Sheets: Visco Elastic (Memory)	42
Foam: Bolsters	46-48
Foam: Channeled	40
Foam: Closed-Cell	41, 43
Foam: Cutters	146-147
Foam: Fabricating Ref.	14, 45, 52-59
Foam: Mattress Cores	42
Foam: Mattress Toppers	42
Foam: Poly laminate	51
Foam: References	8-17
Foam: Sculpting Discs	146
Foam: Shredded	44
Foam: Skins	44
Foam: Soundproofing	51
Foam: Wedges	46-47
FOC Earth Leather	210
Forbid Top Coat Info	190
Foss Carpet	162
Frame Gun	114
French Gimp	151
Furniture Covers	149
Furniture Covers	86, 149
Furniture Polish	108
Futon Core	68

AUTOMOTIVE • FURNITURE • MARINE

VINYL SUMMARY GUIDE ON PAGES 164-167



G Clips	91
G Grain (Enduratex)	195
G Grain (Spradling)	173
Ganging Device	148
GelFoam	44
Gemini (Spradling)	172
Gimp	151
Gimp Gun	113
Gimp Staples	112
Gimp Tacks	115
Glide: Silicone	109
Glides	133
Glue	100-105
Glue Guide	105
Glue Guns	106
Gran Reserva (Enduratex)	188
Grand Prix (Spradling)	173
Grand Sierra (Boltaflex)	198
Grand Vista (Enduratex)	188
Grille-Tex Fabric	240
Grip-Pad	144
Grommet Dies	219-220
Grommet Kits	221
Grommets	123, 221
Gunslinger (Culp)	197
Gym Mat Cover	156



Hair Pad: Rubberized	86
Halofil	63
Hammers	138
Hampton (Enduratex)	195
Hampton Perforated (Enduratex) ..	195
Hand Setting Dies	220

Hand Stapler	114
Handsewing Thread	73
Handy Jr. Button Machine	127
Hanger Bolts	133
Hangers	148
Harmony (Boltaflex)	198
Headliner (Automotive)	233
Headliner Clips	226
Headliner Tucking Tools	229
Healthcare Fabric	154
Heat Gun	229
Heat Liner	232
Heel Pads	223
Heidi (Enduratex)	195
Heidi (Spradling)	173
Helicals	91
Hickory Mallet	138
Hide-A-Bed Unit	95
Hidem Welt	222
Hinge Links	92
Hog Ring Pliers	138-229
Hog Rings	228
Hog/Horse Hair (Loose)	89
Honda (Enduratex)	195
Hook Buttons	126
Hooks	144, 238
Hoses & Attachments	107
Hospital Ticking	86
Hot Knife	229
Hotmelt Glue Gun	107
Hotmelt Glue Sticks	103
Hydrotuff	154



Ice Fishing Canvas	154
Ice Pick Regulator	137
Independence (Enduratex)	189
Infiniss Faux Leather	208

Insul-Firm	67
Insul-Soft	67
Intes Webbing	77
Invisible Thread	72
Islander (Spradling)	174



Jacket End Zippers	216
Jetstream (Enduratex)	189
Jiffy Cleaner	136
Jiffy Steamers	136
Jiffy Trim	223
Jute Webbing	78



KAI Shears	142
Kal-Glass	234
Kapok Pillows	89
Kevlar Thread	73
K-Grip Adhesive	101-102
Klinch-It Clips/Tool	90
Knives	140
Kodiak (Enduratex)	203
Komatex Board	224
Kraft Paper	150
Kwik-Spray Adhesive	100-101



Landau Tops	235
Laquer	134
Latex Foam	35
Leather	210

AUTOMOTIVE • FURNITURE • MARINE

VINYL SUMMARY GUIDE ON PAGES 164-167

Leather Cleaner	108
Leather Needles	137
Leather Stretcher	139
Leg Plates	133
Levante (Boltaflex)	199
Lift-The-Dot Fasteners	217
Lighthouse (Enduralex)	190
Listing	222
Longitude (Enduralex)	191
Longitude (Spradling)	174
Loose Dacron	66
Lubricant	149
Lunar (Enduralex)	191
Luxor (Enduralex)	195



Madrid (Enduralex)	195
Madrid (Spradling)	174
Mag Daddy Fasteners	230
Magic	213
Magnetic Hammer	138
Mallets	138
Mammut Leather	210
Marathon Contract Fabric	212
Marine Carpet	162
Marine Headliner	163
Marine Hidem Welt	222
Marine Rope	241
Marine Tacking Strip	117
Marine Transfer Tape	215
Marine Underlining	163
Marine Windows	163
Mariner (Nautolex)	200
Markers	145
Marlin (Spradling)	174
Marshall Units	93
Mattress Ticking	86
Mattress Toppers	35, 42

Mattress: Hide-A-Bed	95
Measuring Tape	141
Memory Foam	42-43
Mercedes (Enduralex)	195
Metal Bobbins	149
Metal Glides	133
Metal Legs	131-132
Metal Regulator	137
Metal Ruler	141
Metal Tack Strip	116
Micro Down Pillow Forms	88
Midwest Duck	152
Milled Pebble (Enduralex)	195
Milled Pebble (Spradling)	175
Misc. Vinyls Guide	166
Molded Carpets	225
Monofilament Thread	72
Montana (Enduralex)	195
Montana (Spradling)	175
Monticello (Enduralex)	195
Monticello (Spradling)	175
Morbern Collection Guide	166
Mulsin	85



Nail Puller	120
Nail Strip	122
Nails	91, 115
Nassimi Collection Guide	167
Naugahyde Collection Guide	167
Navigator (Spradling)	175
Needle Kit	137
Needles	137, 140
Neoline Polyester Cord	241
Neoprene	41, 43
New Soho (Nassimi)	200
Nib Back	224

Nippers	138
Nissan (Enduralex)	195
No-Fray Spray	109
Non-Slip Padding	144
No-Sag Springs	91
No-Sag Tools	92
No-See-Um Screening	155
Nuance (Spradling)	176
Nuvtex	208
Nylon Glides	133
Nylon Pack Cloth	155
Nylon Tacking Strip	117
Nylon Thread	70-71, 73-74
Nylon Webbing	239



Oil	149
Oregon Trail (Culp)	197
Original Automotive Leather	237
Orion (Spradling)	176
Ossie (Enduralex)	191
Outdoor Furniture Fabric	157-159
Oxen (Enduralex)	195
Oxen (Spradling)	176



P-3 Bostitch Hand Stapler	114
Packaging Wrap	50
Panel Chipboard	116
Panel Clips	148
Panel Fasteners	223
Panel Nails	115
Patriot Plus (Spradling)	177
Pattern Chipboard	150
Pattern Paper	150

AUTOMOTIVE • FURNITURE • MARINE

VINYL SUMMARY GUIDE ON PAGES 164-167

P continued

Paul Bunyon (Enduralex).....	204
Pegasus (Spradling).....	178
Pencils & Pens.....	145
Perforated Vinyl	163, 192, 195
Perforating Service	237
Permablok Top Coat Info	177
Phantom (Enduralex)	192
Phifertex	159
Pillow Fill	63, 66, 89
Pillow Forms.....	88-89
Pillow Springs	90
Pinch Dogs	140
Pincore	35
Pinpoint Binding	226
Pins.....	137
Piping	80-81
Piping Tins	141
Pirelli Webbing.....	77
Plastic (Hard) Weltcord	81
Plastic (Soft) Weltcord	81
Plastic Pane Windows	234
Platform Rocker Springs.....	94
Platinum 150 Adhesive	104
Pleated Vinyl (Nassimi)	180
Pleated Vinyl (Spradling)	172
Pliers.....	138
Pli-Grip.....	117
Pneumatic Staple Guns	113
Pneumatic Lubricant	149
Pneumatic Powered Ripper	144
Polaris (Spradling)	178
Poles	241
Polish	108
Polyester Cord/Rope	241
Polyester Cushions	68
Polyester Fill	62-63, 66
Polyester Thread	72-74
Polyester Webbing	241

Polyfelt	67
Polyflex	87
Polylaminate Foam	51
Polypropelene Webbing	239
Pool Table Cloth	154
Pooltex	153
PreFixx Top Coat Info	199
Prelude (Spradling)	178
Premier	104, 135
Press: Upholstery	147
Press-N-Snap Tool	220
Prizm (Enduralex)	192
Profiles (Foam Ref.).....	14,45, 52-59
Promotional Vinyl (Enduralex).....	204
Promotional Vinyl (Spradling).....	204
Prong Tufter.....	141
Prop 65 Information	168-169
Pull-The-Dot Fasteners	217
Punch Tools (Revolving)	141
PVC (Hard) Weltcord	81

Rectangular Pillows	88
Recycled Leather.....	196-197
Reflex (Spradling)	179
Regulators	137
Renaissance (Spradling).....	179
Revolving Punches	141
Ring-Flex	87
Ripping Chisel	139
Rocker Springs.....	94
Rotary Fabric Cutter	142
Rubber Bands	92
Rubber Mallet.....	138
Rubber Webbing	77
Rubber Webbing Stretcher	139
Rubberized Curled Hair	86
Ruffino (Spradling)	179
Rulers.....	141

S

Saws	146-147
Scissors.....	142-143
Screening.....	155
Screws	231
Scroll Gimp.....	151
SeaBreeze (Spradling)	180
Sealer.....	134
Seam Rippers	140
Seam Stretcher	141
Seam Tape.....	79, 215
SeaQuest (Nassimi).....	180
Seat-A-Lators	223
SEM Coating Products	240
Sew Foam.....	40
Sewing Awl	140
Sewing Machine Needles.....	140
Sewing Machine Oil	149
Sewing Machine Welt Feet.....	149
Shear Sharpener	143

Q

Quick Nailer (Dec. Tack Spacer).....	120
Quilted Vinyl	172, 180

R

Ragg Topp	234
Rapper (Enduralex)	203
Ratchets	242
Rave (Spradling)	209
Rawhide Mallet	138
Razors	140
Ready Made Welt	222
Recast (Culp)	197

AUTOMOTIVE • FURNITURE • MARINE

VINYL SUMMARY GUIDE ON PAGES 164-167

T continued

Tradewinds (Enduratex)	193
Transfer Tape	215
Trash Tarp	153
Trex (Spradling)	182
Tri Glide	239
Trim Adhesive	100, 102
Trim Clips	226
Trim-Flex	87
Truck Bows	228
Truck Seat Welt	222
Trunk Lining	225
Tufting Clasps	141
Tufting Needles	137
Tufting Needles	141
Tunnel Ties	240
Tweezers	140
Twilight	156
Twill Tapes	79
Twine	75
Twist Pins	137

U

Ultra-Soft Synthetic Down	66
Umbrella Fabric	159
Underlining	163
Upholstery Pins	137
Upholstery Press	147
Upholstery Springs	90
Upholstery Tacks	115
Urban Exotics (Culp)	197
Urethane Top Coat	134

V

Vaquero (Enduratex)	194
Velcro	214-215, 228
Velcro: Clothback Foam	40
Velcro: Super Adhesive	215
Velour	213
Velstick Auto Velcro	228
Velvet	213
Velvet Edge Tackite	116
Vent Punch	127
Ventilator Dies	126
Ventilators	126
Verona (Enduratex)	194
Verona (Spradling)	182
Versare	82
Vinyl & Fabric Cleaner	234
Vinyl & Leather Cleaner	108
Vinyl Cement	103
Vinyl Repair	103
Vinyl Tack Strip	81
Vinyls	164-209
Volara	41

W

Wallaby (Enduratex)	195
Wallaby (Spradling)	182
Washers	231
Webbing Clips	77
Webbing Stretcher	139
Webbing Tacks	115
Webbing: Cotton	79
Webbing: Elastic	77
Webbing: Jute	78
Webbing: Nylon	239
Webbing: Polyester	239

Webbing: Polypropelene	239
Webbing: Rubber	77
Webbing: Steel	79
Webbing: Synthetic Jute	78
Webbing: Sytex	78
Wedges	46-47
Welt Feet	149
Welt Guard	81
Weltcord	80-81
Welting	222
Wet Suit Neoprene	43
Whisper (Spradling)	183
Windlace	223
Windsong (Enduratex)	194
Wire Snap	238
Wire-On	234
Wiss Shears	143
Wollsdorf Leathers	210-211
Wood Buttons	144
Wood Epoxy	104
Wood Finish/Stain	134-135
Wood Legs	128-131
Wood Plugs	144
Wood Ruler	141
Wooden Dowel	144
Woven Cane	150

X Y Z

Xtreme Seal	224
Xtreme Seating (Enduratex)	203
Yardage Chart	214-215
YKK Zippers	218
Zander (Spradling)	183
Zig-Zag Repair Kit	92
Zippers	76, 216
Zippers: Aluminum	76
Zippers: Cut to Length	76, 216
Zippers: Nylon	76

Return both certificates, each properly filled out to Active Foam Products, Inc. One is for the State Department of Revenue, and one for our records.

CERTIFICATE OF RESALE

To: Active Foam Products, Inc.

The undersigned hereby certifies that all tangible property hereafter purchased by him/her is for purposes of resale, and assumes liability for payment of Retailers' Occupation Tax, Service Occupation Tax or Use Tax with respect to receipts from the resale of this property to users or consumers.

This certificate shall be considered a part of each order which we shall give, unless such order otherwise specifies.

Purchaser Name _____ Date _____

Address of Purchaser _____

City _____ State _____ Zip Code _____

Signature of Purchaser _____
(or Authorized Agent)

Certificate of Registration
Number of Vendor

Certificate of Registration
Number of Purchaser

CERTIFICATE OF RESALE

To: Active Foam Products, Inc.

The undersigned hereby certifies that all tangible property hereafter purchased by him/her is for purposes of resale, and assumes liability for payment of Retailers' Occupation Tax, Service Occupation Tax or Use Tax with respect to receipts from the resale of this property to users or consumers.

This certificate shall be considered a part of each order which we shall give, unless such order otherwise specifies.

Purchaser Name _____ Date _____

Address of Purchaser _____

City _____ State _____ Zip Code _____

Signature of Purchaser _____
(or Authorized Agent)

Certificate of Registration
Number of Vendor

Certificate of Registration
Number of Purchaser

CREDIT APPLICATION

The undersigned, hereby applies to Active Foam Products Inc. , for permission to charge purchases on an open account; and if such charges are made, the undersigned agrees to the following terms and conditions:

1. To pay in full the account balance due thirty days after invoice date.
2. To pay a Finance Charge computed at the periodic rate of 1.5% per month beginning on the 35th day from date of invoice. (Annual percentage rate is 18%.)
3. To pay reasonable collection costs and attorney's fees if the account is in default.
4. Active Foam Products Inc. can at any time refuse to permit further purchases, or may limit the amount of items that can be purchased.
5. The undersigned discloses the following credit information for the purpose of obtaining open account privileges. Please fill out completely . Orders will be shipped COD-CASH until credit is approved.

COMPANY NAME _____ PHONE _____
 ADDRESS _____ FAX _____
 CITY _____ STATE _____ ZIP _____
 RESALE NUMBER _____ TAX I.D. _____
 OWNER'S NAME _____
 E-MAIL ADDRESS _____ WEB SITE _____

TRADE REFERENCES: PLEASE INCLUDE FAX NUMBERS TO HELP EXPEDITE THE CREDIT PROCESS.

1 FIRM NAME _____ PHONE _____
 ADDRESS _____ FAX _____
 CITY _____ STATE _____ ZIP _____ ACCOUNT # _____

2 FIRM NAME _____ PHONE _____
 ADDRESS _____ FAX _____
 CITY _____ STATE _____ ZIP _____ ACCOUNT # _____

3 FIRM NAME _____ PHONE _____
 ADDRESS _____ FAX _____
 CITY _____ STATE _____ ZIP _____ ACCOUNT # _____

PERSONAL GUARANTY

The undersigned personally guarantees this account in consideration of Active Foam Products Inc. selling the customer on an open account, and will be obligated under the terms of the above agreement.



BUSINESS HOURS: 8:00 to 4:30 Monday through Friday

TERMS AND CONDITIONS: Our regular terms are net 30 with approved credit. All invoices past 30 days will be subject to a service charge of 1.5% per month (annual percentage rate of 18%). We will be pleased to set up an open account for your business. Our credit department will expedite your order and contact your firm when additional information is required. Credit card, COD or prepaid options are also available.

SALES TAX: We will add sales tax as required by law. If you are tax exempt, please submit a copy of your tax exemption certificate with your order. SALES TAX is required by state law to be charged on all tools except for resale. A note will be needed for our records for this exemption.

NSF CHECKS: All checks returned to us due insufficient funds will be subject to a \$30.00 service charge.

PRICING AND AVAILABILITY: Due to raw material costs beyond our control, we reserve the right to adjust our pricing without notice. While products shown are available at the time of publication, continued availability can not be guaranteed.

OUT OF STOCK ITEMS: If an item ordered is temporarily out of stock, you will be notified when it is available and when to expect shipment.

FREIGHT TERMS: All prices are FOB (freight-on-board) from our warehouse.

LOCAL DELIVERY CHARGES: Please check with us regarding delivery scheduling and minimums for your location.

U.P.S. SHIPMENTS: Orders for stock items placed by 3:00 P.M. will be shipped same day. We do our best to ship your order the same day it is received. Please phone your orders as early as possible to assure same day service. If you need fabricated foam pieces or non-standard foam sheets, please place your order as soon as possible in order to give our cutters time to cut your foam to your specifications.

DAMAGED GOODS: Despite our best efforts, items may become damaged or lost in transit. Be sure to count the number of packages and to inspect all cartons for damage BEFORE you sign the delivery receipt, List any shortage or damage on the delivery ticket. Ask the driver to make an inspection immediately. Keep the shipping carton, packing material and merchandise intact until the claim is resolved. Contact our Customer Service Department for help in filing your claim, or to order replacement goods.

RETURNS / EXCHANGES: We make every effort to ship your orders correctly. If an error does occur, or you experience difficulty with any product, please call our Customer Service Department. Merchandise will be replaced or credited ONLY with proper approval. Return merchandise in original packaging when possible. Active Foam will not be responsible for damages resulting from improper customer repacking. Enclose a copy of the invoice or packing slip with an explanation in writing.

LIMITED WARRANTY: Active Foam Products, Inc. shall not be liable for any injury, loss or damage arising out of the use, or inability to use, any item sold by us. Our only obligation in lieu of all warranties expressed or implied, is to replace any item proved to be defective. The user must determine the suitability of the product for its intended use and assumes all risk in connection therewith.

SALES ASSISTANCE: Our sales staff is available for consultation and advice on technical questions, product information, and specifications. They will be happy to help you find the right product to meet your requirements.

SAMPLES: Product samples are available for many of the items we carry. Please contact a member of our sales staff if you require samples of our foam or supply products.

VACATION SCHEDULE: We will be closed on New Years Day; half day for Good Friday; Memorial Day; July 4th; Labor Day; Thanksgiving and the day after; Christmas Eve day and a half day before; and Christmas Day. Active Foam observes holidays falling on Saturdays on the preceding Friday, and holidays falling on Sunday the following Monday.

CATALOG FORMAT: This catalog is organized in six general categories: Foam, Polyester Fibers, Upholstery Supplies, Vinyls and Canvas, Automotive and Maritime Supplies, and Refinishing Supplies.

COPYRIGHT ACTIVE FOAM PRODUCTS, INC.: Original artwork and information may not be copied without written permission from Active Foam Products, Inc.



7 1/2 Yards

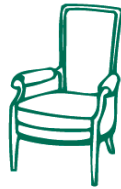

2 1/2 Yards



4 Yards

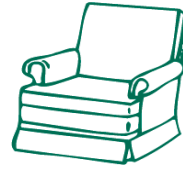

7 Yards



5 Yards



5 Yards



6 1/2 Yards



5 Yards



8 Yards



4 Yards



5 Yards



4 1/2 Yards



7 Yards



3 1/2 Yards

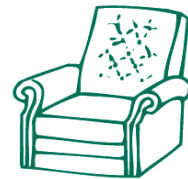

6 Yards



6 Yards



6 1/2 Yards



6 1/2 Yards



2 1/2 Yards



1 1/2 Yards

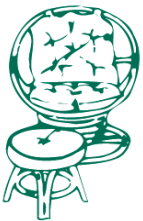

5 Yards



1 1/2 Yards



1 1/2 Yards



2 1/4 Yards



1 1/2 Yards



3 1/2 Yards



4 1/2 Yards



4 1/2 Yards



4 1/2 Yards



2 1/2 Yards



5 Yards



34 Yards



6' — 10 Yards
7' — 11 Yards
9' — 13 Yards



6' — 10 Yards
7' — 11 Yards
9' — 13 Yards



6' — 12 Yards
7' — 14 Yards
9' — 16 Yards



6' — 12 Yards
7' — 14 Yards
9' — 16 Yards

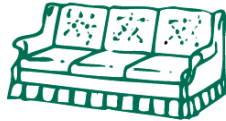

14 Yards



16 Yards



11 Yards

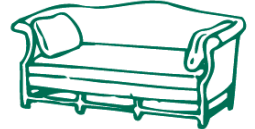

11 Yards



12 Yards

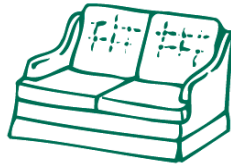

10 Yards



10 Yards



2 1/2 Yards

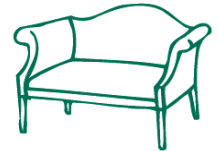

6 Yards



6 Yards



6' — 16 Yards



13 Yards



3 Yards



5 1/2 Yards



5 Yards

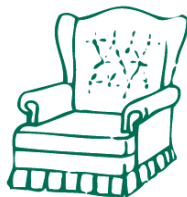

6 1/2 Yards



5 1/2 Yards



4 Yards



6 Yards

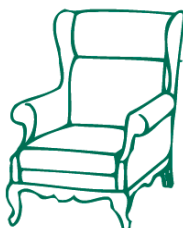

6 Yards



4 Yards



7 Yards



2 1/2 Yards



3 Yards

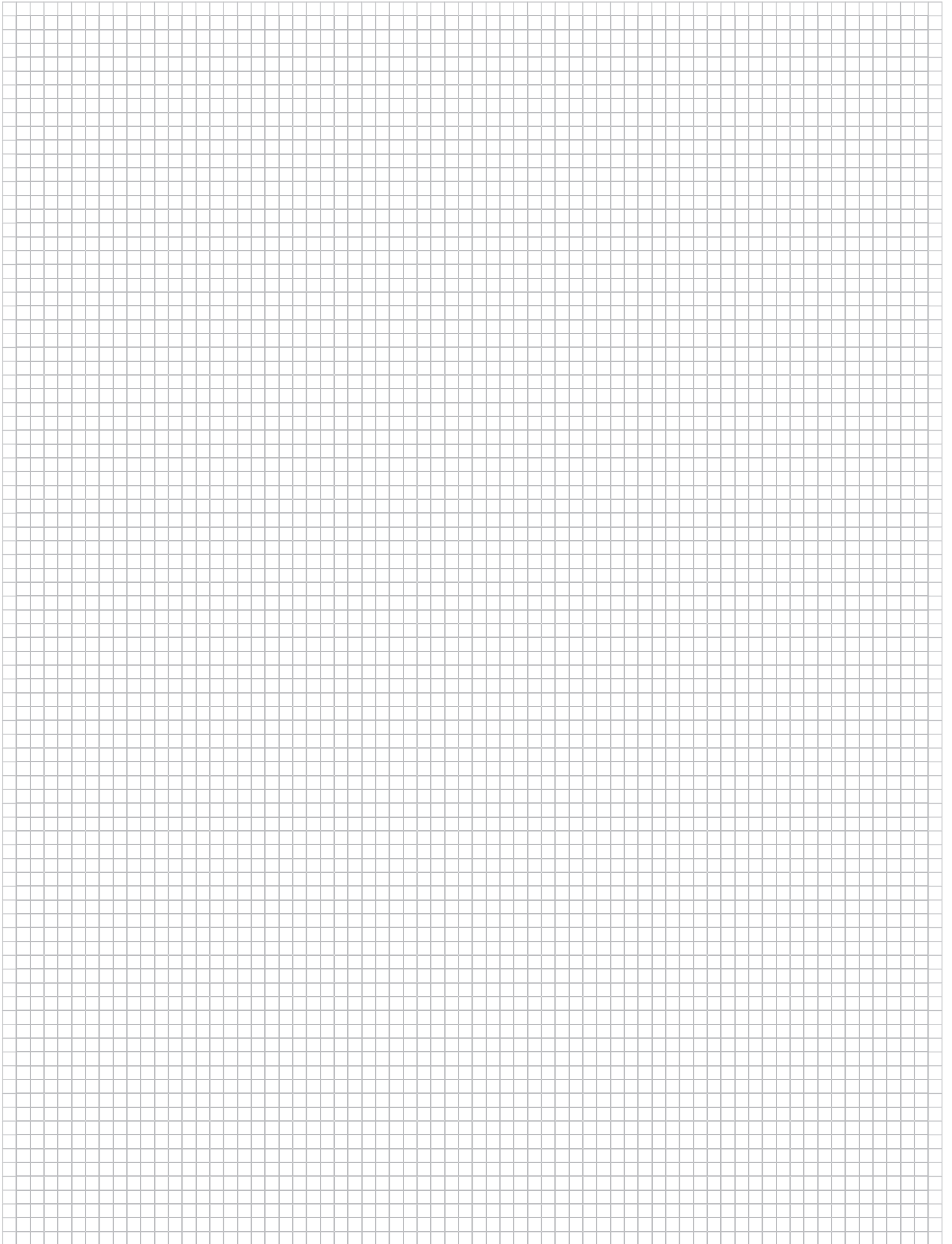



ACTIVE

FOAM PRODUCTS, INC.

***Foam Fabricating
& Supplies For:***

Upholstery—Automotive

Maritime—Furniture

All Same Day—UPS Service

CHICAGO

4358 South Knox Ave.
Chicago, IL 60632
T: 800-728-4567
V: 773-582-5400
F: 773-582-1955

MILWAUKEE

6210 West Douglas Ave.
Milwaukee, WI 53218
T: 800-347-3603
V: 414-462-9220
F: 414-462-9222

EASTPOINTE

17630 East 10 Mile Rd.
Eastpointe, MI 48021
T: 866-316-4567
V: 586-778-5400
F: 586-778-5415

NORTH LIMA

12037 South Avenue
North Lima, OH 44452
T: 800-788-6096
V: 330-629-9454
F: 330-629-9455